

The Spatial Separation of Signals by the Curvature of the Wave Front

Alexander Okorochkov¹, Bogdan Malyutin¹

Abstract: In this paper, a new method of spatial separation of several signals with different curvatures of the wave front is proposed. The method is based on the formation of a particular interference field structure of each signal in the location of the receiving antennas by means of a transmitting phased sparse linear array antenna. The peculiarity of the interference electromagnetic field consists in periodically repeating areas in which the amplitude of the useful signal is many times greater than the amplitudes of the other transmitted signals, which are electromagnetic interference. In addition, the electromagnetic interference signal in this area consists of practically two antiphase components. If in this area a reflective passive phased antenna array is placed, which will focus the useful signal while reflecting, it will be increased, and the interference signal will be significantly weakened. This method of signal separation allows simultaneous transmission of several signals in the same frequency band, in one direction and on one polarization, which increases the information transmission speed in communication systems.

Keywords: Spatial signal separation, Wavefront curvature, Reflective passive phased antenna array, Signal-to-noise ratio, Phased sparse antennas array.

1 Introduction

Increasing the speed of information transfer is an important task in the design of communication systems. The speed of information transmission can be increased either by changing the parameters of one communication channel (bandwidth expansion, by using methods of multi-position manipulation of digital signals, etc.) [14], or by organizing several parallel channels through which radio signals are transmitted with the same one or several information parameters, such as the frequency band, the type of polarization, the direction of propagation, time intervals for transmission of radio signals, etc. This approach is otherwise called re-use of the corresponding information resource [5]. In this case, there is always a problem of separating signals on the receiving side

¹Institute in Shakhty of DSTU, Shevchenko 147, Shakhty 346500, Rostov region, Russia;
E-mails: okorochkov_a@mail.ru, bogdan.world@mail.ru

according to the mismatching information parameter. So, for example, in the case of satellite communication, when signals are simultaneously transmitted in the same direction and in the same frequency band, the polarization signal separation is used [10].

Of all known methods of separating radio signals in communication systems, the method of signal separation by wave front curvature (CVF) has not been used up to now. The use of this radio waves parameter to enhance the characteristics of measuring systems, object detection systems, interference suppression, and improvement of antenna directional characteristics in radar and hydro acoustics has been widely discussed in the scientific literature for the last three decades [1, 2, 8, 11, 12 and 15].

The term "wave front curvature" refers to an electromagnetic wave, transporting information signal in space, but for convenience, we will use the term "wave front curvature of the signal" in the following. Fields of signals with different CVF are formed using a special transmitting antenna system - a sparse linear antenna array (SAA). If necessary, the model of the transmitting antenna system can be generalized for a planar or volume nonuniform sparse antenna array.

Separation of signals from different CVF at the reception can be carried out in various ways [6, 13], which will be considered further. It is important to note that when receiving several signals with different CVF can be separated, but with coincident other information parameters: the direction of transmission, the transmission time interval, the polarization, the frequency band, i.e. it is possible to use the same values of specified information parameters several times when transmitting several signals. The maximum number of such signals, as will be shown below, is equal to the number of transmission antennas in the SAA (if all antennas transmit each signal).

2 Problem Formulation

In the works [7, 13] one of the methods of constructing a communication system based on the signal separation with different CVF is proposed and investigated. The block diagram of the radio link of such a communication system is shown in Fig. 1. Designations in Fig. 1 have the following values: S_1 and S_2 – are signals at the inputs of the transmitting equidistant linear SAA1; SAA2 – is receiving equidistant linear SAA; L1 and L2 – are the periods of the antenna arrays SAA1 and SAA2; A_{nm} – are antennas that are part of SAA1 and SAA2 ($n=1,2; m=\overline{0,2}$); d – is a range of communication; X, Y, Z – are the axis of the Cartesian coordinate system, the center of which is combined with the phase center of the receiving antenna A_{20} ; d_{mx} – is the distance between the

centers of the transmitting antennas and the point x on the abscissa axis in the plane of the SAA2 opening; θ_{mx} – are the angles of directions from the centers of the transmitting antennas to the point with the abscissa x in the plane of the SAA2 opening; S_1^* , S_0^* , S_2^* – are signals at the outputs of receiving antennas.

[1]

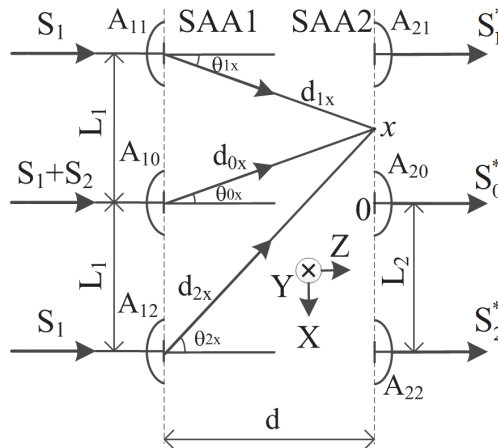

Fig. 1 – Block diagram of the communication system with the separation of signals S_1 and S_2 by the CVF.

The transmitting and receiving SAA consist of each of three identical axisymmetric mirror antennas, the directions of the main beams of which are parallel to the Z – axis.

Consider the principle of operation of such a communication system in the transmission of two signals S_1 and S_2 in the same frequency band Δf . The signal S_1 is fed with the same amplitude to the inputs of all three antennas of the transmitting SAA1, and the signal S_2 – is only to the input of the central antenna A_{10} . As a result of scalar summation of fields (signals S_1 and S_2 radiated at the same polarization), emitted by all antennas SAA1, in the plane of the opening of the receiving linear SAA2, due to interference, is formed along the X - axis of the electromagnetic field with a complex spatial structure, generally different in the opening of each receiving antenna.

Fig. 2 shows the distribution of the amplitudes $B_n(x)$ ($n=1,2$) of the fields of both signals along the X – axis for the following values of the parameters: $d=10\text{km}$, $L_1=10\text{m}$, wavelength is $\lambda=2\text{cm}$, radius of the mirror antennas is $a=0,5\text{m}$. Amplitudes of the fields are given in relative units. The ratio of the

signal amplitudes at the inputs of the transmitting antennas was $S_1 : S_2 = 1 : 3$. In Fig. 3 the distribution of the phases $\Phi_n(x)$ of these fields is shown.

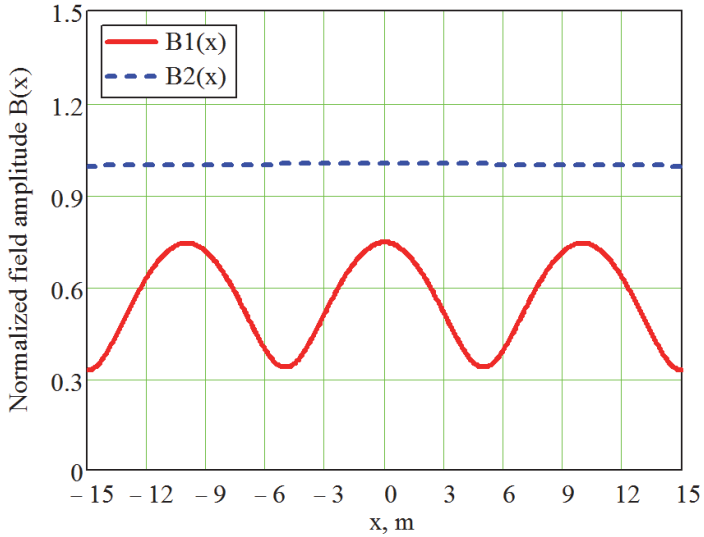

Fig. 2 – Distribution of the amplitude of the signal fields S_1 and S_2 along the X - axis.

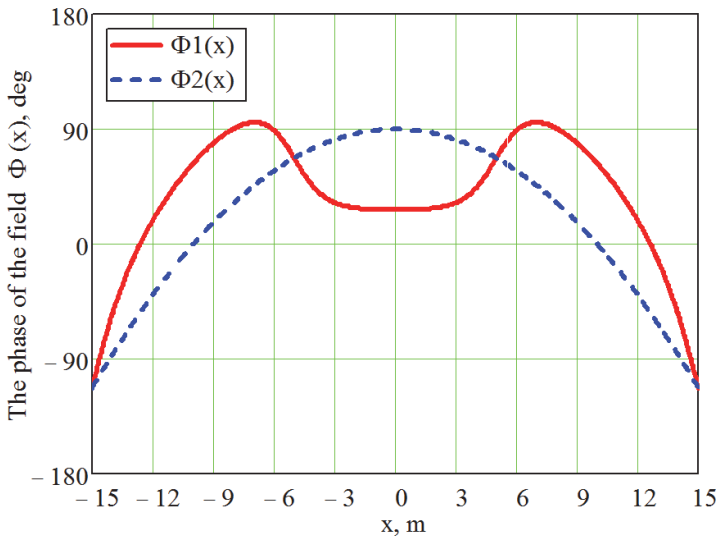

Fig. 3 – Phase distribution of the signal fields S_1 and S_2 along the X - axis.

The apparent difference between the distributions of the amplitudes and phases of both signals is a consequence of the difference in the CVF of these signals.

The graphs in Figs. 2 and 3 are based on mathematical models of the signals fields and when the approximate relations are satisfied (Fig. 1)

$$d_{mx} \approx d; m = \overline{0, 2}, \quad (1)$$

which follow from the conditions of space-time narrow-band signals [8, 9].

For the signal S_1 the mathematical model of the field in point x (Fig. 1) has the following form [13]:

$$\dot{S}_1(t, x) = \alpha \dot{S}_{r1} \left(t - \frac{d}{c} \right) e^{i\omega_0 t} \sum_{m=0}^2 e^{-\beta d_{mx}} F(\theta_{mx}). \quad (2)$$

For a signal S_2 the field model is described by the formula

$$\dot{S}_2(t, x) = \alpha \dot{S}_{r2} \left(t - \frac{d}{c} \right) e^{i\omega_0 t} e^{-\beta d_{0x}} F(\theta_{0x}). \quad (3)$$

Equations (2) and (3) are obtained under the assumption of homogeneity of the wave propagation medium and the absence of multipath effects.

The values in (2) and (3) have the following meaning: $\dot{S}_{r1,2}(t - d/c)$ – are complex envelopes of signals S_1 and S_2 , in which condition (1) is taken into account; $\beta = 2\pi/\lambda = \omega_0/c$ – the phase coefficient of the wave in free space, ω_0 – is the circular frequency of the carrier wave, c – is the speed of light in free space; $F(\theta_{mx})$ – are the amplitude characteristics of the directivity of the transmitting antennas in the direction towards the point x ; α – is a real multiplier that takes into account the gain of the antenna and the attenuation of the waves on the propagation path, the same for the waves of all signals due to the condition (1) and the homogeneity of the medium. In [13], axisymmetric mirror antennas with a diameter of 1 m with a constant amplitude and phase of the field at the aperture, emitting waves at a frequency, were used as transmitting antennas. For the amplitude characteristic of the circular aperture directivity, the expression known from the theory of aperture antennas was used [4]

$$F(\theta) = (1 + \cos \theta) \frac{J_1(\beta a \sin \theta)}{\beta a \sin \theta}, \quad (4)$$

where $J_1(\theta)$ – is the Bessel function of the first kind of the first order.

When plotting Figs. 2 and 3, the field amplitudes $B_n(x)$ of the signals S_1 and S_2 were calculated according to the formulas:

$$B_1(x) = \left| \sum_{m=0}^2 e^{-i\beta d_{mx}} F(\theta_{mx}) \right|; \quad (5)$$

$$B_2(x) = \left| e^{-i\beta d_{0x}} F(\theta_{0x}) \right|. \quad (6)$$

The values of the phase fields $\Phi_n(x)$ were calculated in the following way:

$$\Phi_1(x) = \arg \left[\sum_{m=0}^2 e^{-i\beta d_{mx}} F(\theta_{mx}) \right], \quad (7)$$

$$\Phi_2(x) = \arg \left[e^{-i\beta d_{0x}} F(\theta_{0x}) \right]. \quad (8)$$

The first stage of spatial signal processing in the considered communication system ends with the formation of electrical signals S_1^* , S_0^* , S_2^* at the outputs of the receiving SAA2.

At the second stage, the optimal spatial processing of signals from the outputs of the receiving SAA2 (Fig. 1) was performed to extract useful signals at the receiver inputs by the criterion of the maximum signal-to-noise ratio (S/N) [9]. In [7] noise was understood in the generalized sense and included interference (deterministic signals) and noise (random signals). When receiving signal S_1 , interference is signal S_2 , and vice versa.

It is necessary to pay attention to three factors that are important for understanding the essence of the proposed method of spatial separation of signals by CVF in this article.

Firstly, in [7, 13] the choice of parameters of the communication system (d , L_1 and L_2), at which the calculation of the amplitude and phase distributions of fields in the plane of the receiving SAA, as well as the ratio S/N at the input of the receiver is carried out, is not justified. So then the problem arises in finding the optimal position of the receiving antennas relative to the spatial structure of the field in order to achieve the maximum S/N ratio at the inputs of the receiver.

Possible and reverse formulation of the problem: the formation of the optimal spatial structure of the field at the opening of the receiving SAA2 for a given position of the receiving antennas.

Secondly, in connection with the emerging task of forming the optimal spatial structure of the field, it becomes necessary to determine the parameters of the communication system by means of which it can be realized.

It would be most convenient to control the spatial distribution of the radiation field, affecting the characteristics of transmitting antennas using control electric signals, for example, as it is realized in phased antenna arrays

with electronic beam scanning. However, it is impossible in the structure of the communication system proposed in [13].

Thirdly, the authors of [13] pointed out that the communication system proposed by them can effectively operate at ranges lying within the intermediate zone of the radiation field of the transmitting SAA1. This imposes significant limitations on the range of its operation.

All the factors considered limiting the possibilities of the communication system proposed in [13] are successfully overcome in similar communication system of another structure proposed in [6, 3]. Let us pass to the consideration of this system.

3 The Communication System with Spatial Separation of Signals by CVF

In the communication system discussed above, the signals at the receiver inputs were isolated in the scheme of optimal spatial processing of the signals coming from the outputs of the receiving antennas.

In the proposed [6, 3] system of communication with the spatial separation of signals by CVF, this separation is carried out by means of transmitting and receiving antenna systems using spatial properties of fields of the emitted signal waves. The transmitted signals after spatial processing in the receiving antenna modules are immediately allocated to the outputs of the receiving antennas at a certain S/N ratio.

The receiving antenna system consists of identical antenna modules located in certain sections of the interference field and equal in number of transmitted signals. In this case, each module is designed to allocate only one signal, and the other signals for it are electromagnetic disturbances (noise). Each module includes a flat reflective passive phased antenna array (PPAA) and, in fact, a receiving antenna, which can be a simple aperture antenna, for example, horn antenna.

Reflective PPAA is designed to reflect the incident waves and to focus of the useful signal field in the area of the input aperture of the receiving antenna. In the present work, the S/N ratio was defined as the ratio of the power fluxes of the useful signal field and noise through the area of the aperture of the receiving antenna (internal thermal noise of the receiving system is not taken into account here).

The transmitting antenna system is a linear phased SAA (PSAA), the number of elements which determines the maximum possible number of transmitted signals.

The purpose of synthesizing the entire antenna system is to achieve the maximum S/N ratio at the outputs of all receiving antennas.

Carrying out this work, a system of communication with spatial separation of signals by CVF was investigated, in which plane reflective PPAAAs were located along the X – axis in the XY – plane of the Cartesian coordinate system in which the interference field is formed (Fig. 4).

In the considered communication system, the final S/N ratio at the input of the receiving antenna is formed during two stages of spatial signal processing:

At the first stage, at a given communication range and distance between the transmitting antennas, an optimal structure of the interference field in the plane of the reflective PPAAAs is formed by specifying the amplitudes and phases of the signals at the inputs of the transmitting PSAA. The essence of the term "optimal field structure" will be explained further. The size of the reflective PPAAAs and their position are determined by the interference structure of the field. In this case, the PPAAAs are located where the maximum point of the field amplitude of the useful signal and the zero amplitude point of the noise field (interference) spatially coincide, in which the phase of the latter experiences a jump approximately at π . The noise field thus consists of two almost antiphase components located on opposite sides of the zero amplitude point;

At the second stage of spatial signal processing, the value of the S/N ratio achieved in the first stage is amplified by focusing the useful signal field of the reflective PPAA into a narrow focal zone where the S/N ratio reaches its maximum value. Here, the aperture of the receiving antenna is also located. In this case, the phasing of the reflective PPAA elements, on the one hand, favors focusing and, consequently, amplification of the amplitude of the useful signal field, and on the other hand, it suppresses the amplitude of the interference field due to the presence of two almost antiphase components in it.

4 Analysis of the Conditions for Spatial Separation of Signals in a Communication System with Three Transmit Antennas

The structural scheme of the proposed version of the communication system for the case of three-antenna equidistant linear transmission PSAA and two signals transmitted on the same polarization is shown in Fig. 4. Here S_1 and S_2 – are input signals; Φ_{nm} – are phase shifters, providing phasing laws of the PSAA antennas for signals S_1 and S_2 ; G_{nm} – are blocks for adjusting the amplitudes of signals at the inputs of PSAA; Σ – are adders at the inputs of the transmitting antennas; L – is a distance between antennas in PSAA (step PSAA); A_m – are the PSAA antennas; parameters d , d_{mx} and θ_{mx} have the same meaning as in Fig. 1; PPAA1,2 – is a flat reflective linear PPAAAs for focusing signals S_1 and S_2 , accordingly; RA1,2 – are receiving antennas, at the inputs of which signals fields S_1 and S_2 are formed; X, Y, Z – are the axes of

the Cartesian coordinate system associated with the plane of the PPAA's location (XY-plane).

The scheme in Fig. 4 in comparison with the scheme in Fig. 1 has the following essential features:

- for fixed values of distances L and d smooth adjustment of phase shifts for each signal at the inputs of the transmitting antennas allows the structure of the interference field of each signal to be smoothly and continuously changed along the X -axis;

- each signal is transmitted by all three antennas A_m ;

- on the receiving side reflective flat PPAA's are used, which ensure focusing of the reflected fields of useful signals in the region of the location of the receiving antenna apertures.

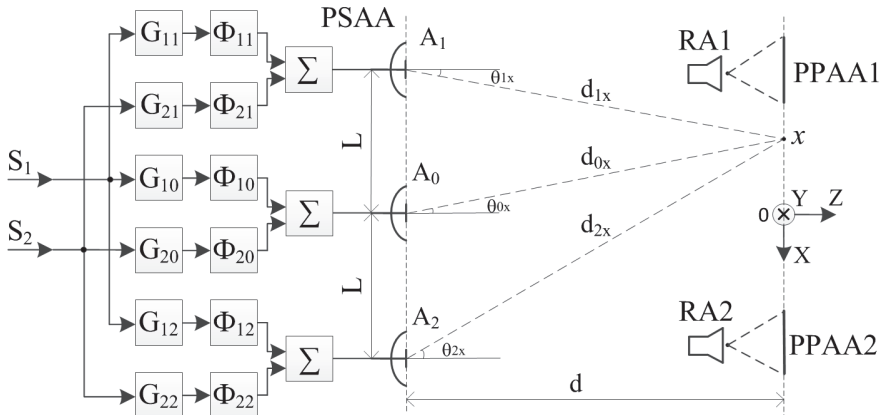

Fig. 4 – Block diagram of the communication system with spatial separation of two signals S_1 and S_2 by CVF.

To analyze the conditions for the formation of the maximum S/N ratio in the first stage of spatial signal processing, it is necessary to construct a mathematical model of the field of a single signal in the plane of the reflective PPAA's. This field is the sum of three radiation fields, each of which is created by one transmitting antenna.

For signal S_1 , the expression for the radiation field in the plane of the reflective PPAA can be written in the form (2) taking into account the initial phase shifts φ_{1m} ($m = \overline{0,2}$) and amplitude coefficients g_{1m} at the inputs of the transmitting antennas

$$\dot{S}_1(t, x) = \alpha \dot{S}_{r1} \left(t - \frac{d}{c} \right) e^{i\omega_0 t} \sum_{m=0}^2 e^{i(\varphi_{1m} - \beta d_{mx})} g_{1m} F(\theta_{mx}). \quad (9)$$

To get the expression for the signal field S_1 , it is necessary to replace the subscript 1 with index 2 in (9).

It can be seen from expression (9) that the fulfillment of the space-time narrowband condition led to its division into two unrelated factors, one of which describes the time properties of the signal, and the second factor-sum describes its spatial properties.

To calculate and plot graphs the dependence of the amplitudes and phases of the signal fields from the coordinate x in the plane of the PPAA opening, it is necessary to use expressions similar to (5) and (7) with allowance for (9).

Since the expression (9) for signals S_1 and S_2 taking into account the replacement of the indices looks the same, it is sufficient to analyze the spatial structure of the field of only one signal by the example of a signal S_1 . To simplify the analysis, we will consider all initial phase shifts of the signal components at the inputs of the transmitting antennas equal to zero.

In Fig. 5 and 6 the graphs of dependences of the normalized amplitude $B_1(x)$ and phase $\Phi_1(x)$ of the signal field S_1 are shown to have been calculated from (9) with the aid of formulas (5) and (7) from the coordinate x in the plane of the location of the reflective PPAA's for the communication range $d = 10\text{ km}$ and two values of the step of the transmitting PSAA: $L = 14\text{ m}$ and $L = 10\text{ m}$. The relative amplitudes of all the fields radiated by each transmit antenna were assumed to be equal to one at the point x .

In Fig. 5 the graph for the step $L = 14\text{ m}$ is characterized by the presence of two series of maxima different in amplitude (the points 0, M, etc.) and deep minima (the points A, D, etc.). In these minima, the normalized field amplitude has a value $\sim 10^{-3}$. Therefore, to identify such minima in the text, we shall call them the "zeroes" of the amplitude. Comparison of the graphs in Fig. 5 and 6 for $L = 14\text{ m}$ (p. p. A and D) shows that the zeroes of the amplitude in Fig. 5 correspond to Fig. 6 phase jumps close to π .

On the graphs for $L = 10\text{ m}$ the amplitude has shallow minimum and the phase in the area of the minimum varies smoothly without sudden jumps.

The indicated features of the graphs for $L = 14\text{ m}$ Fig. 5 and 6 are highlighted because they are based on the proposed further method of increasing the S/N ratio in the first stage of spatial signal processing. To implement this method, it is important that the dependences $B_1(x)$ and $\Phi_1(x)$ have the form of the graphs in Fig. 5 and 6 for the distance $L = 14\text{ m}$, i.e. on the first graph there were zeroes of the amplitude, and on the second graph there was a phase jump at these points, close to π . However, such dependencies are not obtained for any values of the transmission array step L (for fixed parameters d, λ, a).

The Spatial Separation of Signals by the Curvature of the Wave Front

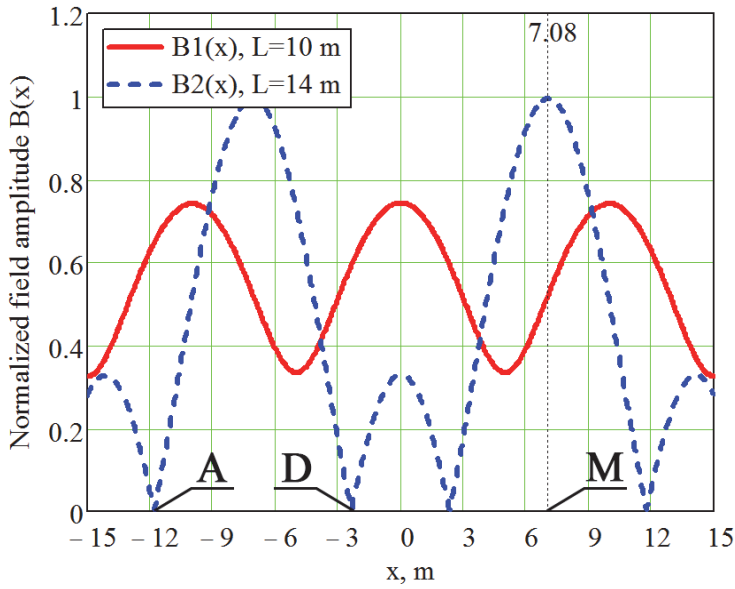

Fig. 5 – Dependence of signal field amplitude S_1 for range $d = 10$ km and different values L .

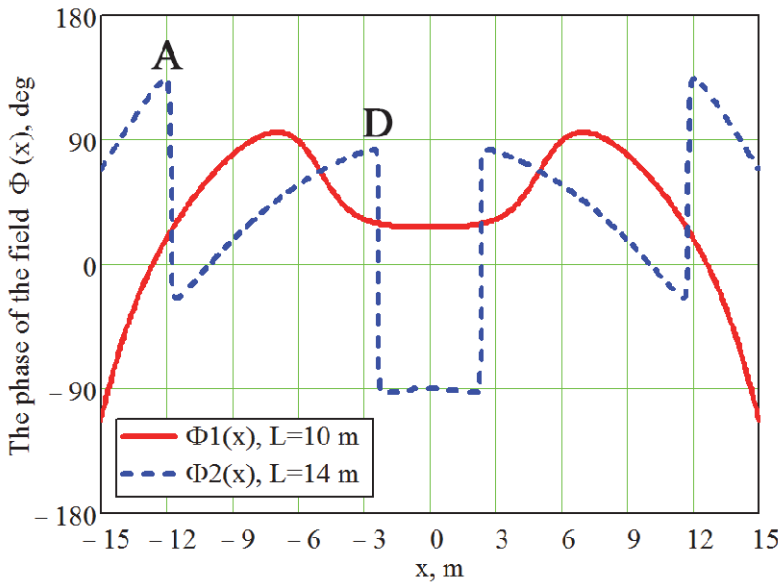

Fig. 6 – Dependence of the phase of the signal field S_1 for range $d = 10$ km and different values L .

To determine the distances L for which the necessary dependences $B_1(x)$ and $\Phi_1(x)$ are obtained, it is necessary to determine the values L for which the equation $B_1(x) = 0$ will have solutions, taking into account (9) it takes the form (for $\varphi_{1m} = 0$):

$$\left| \sum_{m=0}^2 e^{-i\beta d_{mx}} g_{1m} F(\theta_{mx}) \right| = 0. \quad (10)$$

Equation (10) is transcendental and in general form for arbitrary values of the parameters included in it d, λ, a, L and g_{1m} has no exact solution in analytical form. The solutions of equation (10) are the coordinates of points on the X - axis with zero amplitude of the field.

For the analysis and the approximate solution of equation (10), we simplify its left side. Since the structure of the interference field is analyzed on a segment of the X - axis much smaller than the communication range, then the inequality $x/d \ll 1$ must be satisfied. From this condition and the geometry of the structure of the communication system in Fig. 4, approximate relations for the parameters d_{mx} and θ_{mx} in equation (10) it follows:

$$\begin{aligned} d_{0x} &\approx d + \frac{x^2}{2d}, & d_{1x} &\approx d + \frac{(L-x)^2}{2d}, & d_{2x} &\approx d + \frac{(L+x)^2}{2d}, \\ \theta_{0x} &\approx \frac{x}{d}, & \theta_{1x} &\approx \frac{L-x}{d}, & \theta_{2x} &\approx \frac{L+x}{d}. \end{aligned} \quad (11)$$

We also use approximate equalities that are well satisfied under the accepted condition $x/d \ll 1$:

$$F_0(x) \approx F_1(L-x) \approx F_2(L+x). \quad (12)$$

These equations can be made quite accurate by adjusting the amplitude of signals at the inputs of the transmitting antennas.

Taking into account (11) and (12), we write equation (10) in the expanded form

$$\left| g_{10} \exp(i\beta L^2/2d) + g_{11} \exp(i\beta Lx/d) + g_{12} \exp(-i\beta Lx/d) \right| = 0. \quad (13)$$

The last expression is obtained under the condition that the field analysis area does not contain zeroes of the amplitude characteristics of the directivity (12) of the transmitting antennas.

An analysis of (13) using the vector model of complex numbers shows that the amplitude and phase distributions of the interference field along the X - axis will have the above features under the following conditions:

$$g_{11} = g_{12}, \quad g_{11} > 0,5g_{10}, \quad \beta L^2/2d = k\pi, \quad k = 1, 2, 3, \dots \quad (14)$$

The latter condition means that (13) has solutions only for a discrete set of values of the PSAA step

$$L = \sqrt{k\lambda d}. \quad (15)$$

Taking into account the conditions (14), equation (13) is transformed into two simple trigonometric equations

$$\cos(\beta Lx/d) = \pm (g_{10}/2g_{11}), \quad (16)$$

where the signs "+" and "-" refer respectively to the odd and even values of k in (14) and (15). The set of solutions of equations (16) for one particular but practically interesting case $g_{10} = g_{11} = g_{12}$ can be represented in a single form:

$$x_{kl} = \sqrt{\frac{\lambda d}{k}} \left(l \pm \frac{a_k}{6} \right), \quad l = 0, \pm 1, \pm 2, \dots; \quad (17)$$

$$a_k = \begin{cases} 1, & k = 1, 3, 5, \dots; \\ 2, & k = 2, 4, 6, \dots \end{cases}$$

The presence of discrete allowable step values L is a factor of inconvenience for the developers of PSAA, since it limits their capabilities in the variation of this parameter in the design of the transmission array. This problem can be solved with an additional condition. The exponent of the first term on the left-hand side of (13) is the component of the phase of the signal field emitted by the central antenna PSAA. If at the input of this antenna the signal is added with a phase shift

$$\Delta\varphi = -\frac{\beta L^2}{2d} + p\pi, \quad p = 0, 1, 2, \dots, \quad (18)$$

then the first term in (13) will get the values $e^{ip\pi} = \pm 1$ (for the case $g_{10} = g_{11} = g_{12}$), in which the equation under consideration will already have solutions:

$$x_{pl} = \frac{d\lambda}{L} \left(l \pm \frac{a_p}{6} \right), \quad l = 0, \pm 1, \pm 2, \dots; \quad (19)$$

$$a_p = \begin{cases} 1, & p = 1, 3, 5, \dots; \\ 2, & p = 0, 2, 4, \dots, \end{cases}$$

which are valid for any nonzero value L . Thus, the ability to adjust the phase of the signal at the input of the central PSAA antenna allows imparting to the array step L any values from the antenna diameter and above.

The analysis shows that the fulfillment of conditions (11), (12), (14) and (18) allows us to form the necessary structure of the interference field in the plane of arrangement of reflecting PPAA.

Knowing the coordinates of the zeroes of the amplitude, as will be seen later, is necessary for the correct arrangement of the reflective PPAA along the X - axis, and it also affects the choice of their horizontal size.

Let the graph, denoted by the dotted curve in Fig. 5, corresponds to a useful signal S_1 . Then, positioning a planar discrete reflective PPAA in the area of the higher maximum of this graph (the point M), we obtain after the reflection and focusing (at the aperture of the receiving antenna) a higher value of the amplitude of the useful signal field than in the wave incident on the PPAA.

The distribution of the field phase in the reflected focused wave consists of the phase distribution in the wave exciting the individual reflective elements of the PPAA (Fig. 6, dotted curve) and the phase distribution of the reflection coefficient on the PPAA elements. The latter distribution can be realized due to the selection and arrangement in the corresponding nodes of the rectangular grid of the plane PPAA opening reflective elements with the necessary phase of the reflection coefficient [3].

Let now the dotted curve in Fig. 5 corresponds to the amplitude of the field of the interference signal (second signal S_2). Then, when the reflective antenna array is located in the region of any zero field amplitude (for example, at the point A), the right and left parts of the array opening (relative to the zero amplitude) will be excited by fields with almost the opposite phase (see the dotted curve in Fig. 6). Then the fields reflected by the right and left parts of the PPAA opening will also be close to antiphase. When focusing, folding in the aperture area of the receiving antenna, these fields will significantly suppress each other, significantly reducing the amplitude of the signal field S_2 at the input of the receiving antenna.

If the initial relative phase shifts at the inputs of the transmitting antennas, for example for the signal S_1 , are different from zero, this will lead to a change in the interference pattern of the field in the plane of the PPAA location. In the case of the linear law of the distribution of the initial phases along the opening of the transmitting PPAA, the interference pattern of the field on the plane of the reflective PPAA placement does not change in shape, but shifts parallel to itself along the axis to the right or to the left, depending on the slope of the phase characteristic. The linear law of distribution phase can be set as follows: the central transmitting antenna to put $\varphi_{10} = 0$ on the extreme antennas to put $\varphi_{11} = -\varphi_{12} = \varphi_1$. If $\varphi_1 > 0$ so, in accordance with Fig. 4 the field amplitude distribution graph $B_1(x)$ moves in the positive direction of the X -axis, and if $\varphi_1 < 0$ so, the function graph $B_1(x)$ moves in the opposite direction. The graph of the function $\Phi_1(x)$ will behave similarly. All of the above can be applied to the function graphs $B_2(x)$, $\Phi_2(x)$ for the signal S_2 .

Let the angles φ_1 and φ_2 determine the linear law of the distribution of the initial phases at the inputs of the transmitting antennas for the signals S_1 and S_2 , and in this case the relation $\varphi_1 = -\varphi_2 = \varphi$ is fulfilled, where the angle φ is called the parameter of the linear phase distribution. Then the graphs of the functions $B_1(x)$ and $B_2(x)$ are displaced along the X - axis towards each other by a distance determined by the value of the angle φ . The graphs of functions $\Phi_1(x)$ and $\Phi_2(x)$ behave similarly. It is possible to choose the angle φ such that the maximum with the larger amplitude on the graph for the signal S_1 and zero of amplitude on the graph for the signal S_2 coincide at a single point on the X - axis (e.g. at the point D_1 in Fig. 7). The graphs in Figs. 7 and 8 are calculated for the same values of the parameters d, λ, a, L and the amplitudes of the fields, and graphics in Figs. 5 and 6, drawn by a dotted line.

It is easy to see that at the point A_1 in Fig. 7, the zero of the amplitude of the signal field S_1 and the main maximum of the amplitude of the signal field S_2 are spatially combined. The situations observed in Fig. 7 at the points A_1 and D_1 , are periodically repeated at points A_2 and D_2 etc.

The noted features in the structure of the distribution of the amplitudes of the signal fields S_1 and S_2 along the axis X lie at the basis of the proposed method for spatial separation of signals with different CVF.

The distribution of the amplitudes of the signal fields in Fig. 7 in the vicinity of the point D_1 can be used for isolation S_1 as a useful signal in the presence of interference from the signal S_2 . At the point A_1 the situation changes to the opposite: as it is the useful signal S_2 , and the interference signal S_1 .

Since the points A_1 and D_1 in Fig. 7 are spatially separated, then the proposed method is also called *the method of spatial separation of signals with different CVF*.

To select S_1 as a useful signal, it is necessary to place a reflective PPAA in the area of point D_1 (Fig.7). This PPAA will reflect the signal field S_1 in the area with large amplitude and focus it in the area of the aperture of the receiving antenna with greater amplitude. To increase the amplitude of the focused field the phasing elements of the reflective PPAA must be performed in rows and columns.

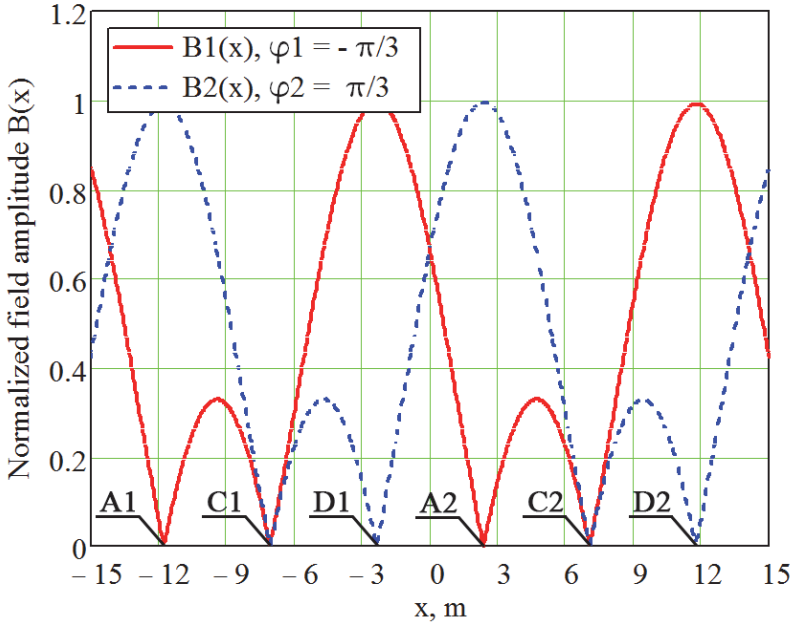

Fig. 7 – Optimal mutual displacements of the graphs of the amplitude functions $B_1(x)$ and $B_2(x)$ under the influence of phase shifts φ_1 and φ_2 .

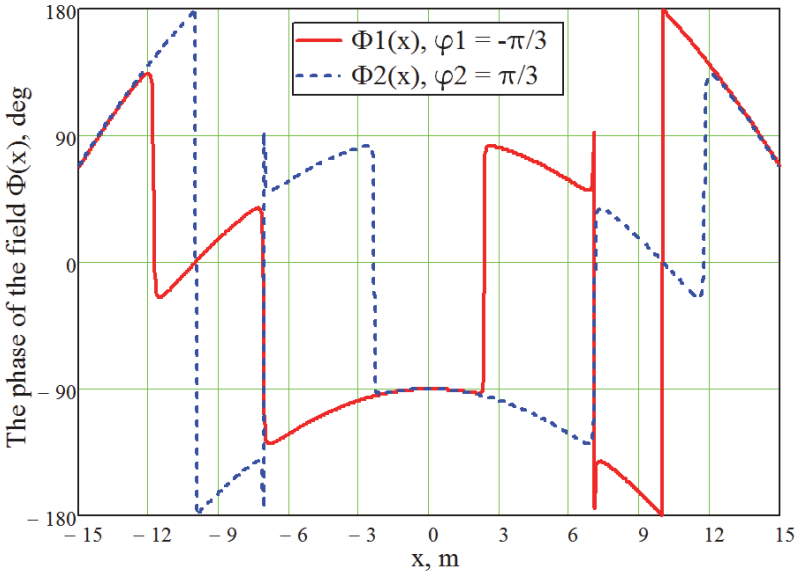

Fig. 8 – Offset of the graphs of phase functions $\Phi_1(x)$ and $\Phi_2(x)$ of two signals under the influence of phase shifts φ_1 and φ_2 .

The interference signal S_2 as a result of interaction with the reflective PPAA will be attenuated for the reasons described above.

Earlier in §3 of this article, listing the factors influencing the formation of the S/N ratio, it was pointed out that it is necessary to form the optimal structure of the interference field in the location plane of the reflective PPAA's. Now we can say specifically that this meant the amplitude distribution of the fields of both signals, shown in Fig. 7.

A careful analysis of behavior of the graph of the amplitude distribution function of any signal in Fig. 7 shows that the sections of the graph to the right and to the left of the zero point of the amplitude are not symmetrical, because they correspond to the branches of small and large maxima of the field amplitude. Therefore, for the maximum mutual suppression of the fields of antiphase components of the interference signal at the aperture of the receiving antenna, the size and position of the reflective PPAA relative to the zero point of the amplitude at the maximum ratio S/N should be selected.

Consideration of the distribution structure along the X -axis of the signal field amplitudes S_1 and S_2 in Fig. 7 suggests that in this figure it is possible to place a graph of the amplitude distribution for the third signal S_3 , adjacent highs which would fall to the points C_1 and C_2 . This distribution structure of field amplitudes for three signals with the same amplitudes at the inputs of all three transmitting antennas and with selected initial phase shifts for each signal is shown in Fig. 9. The graphs in Fig. 9 are calculated and constructed at the same parameter values as the graphs in Figs. 5 – 8.

We note that in the case of three signals due to the selection of the initial phase distributions at the inputs of transmitting antennas can be combined at one point on the X -axis maximum amplitude of the field of one signal and the zeroes of the amplitudes of the other two signals. In case of transmission of four signals by three antennas of such necessary coincidence – one maximum with three zeroes – it is impossible to achieve. Presenting the signals in the form of vectors on the complex plane, it can be shown that the transmission of N signals with spatial separation of them over CVF will require at least N antennas as part of the transmitting PSAA and N receiving antenna modules.

Placing reflective PPAA's, for example, in the area of points U, Q, R (Fig.9), it is possible to receive signals S_1, S_2 and S_3 , respectively, at the outputs of the receiving antennas.

Thus, the conditions for the implementation of a new method of spatial separation of signals in communication systems with the separation of signals by CVF were considered.

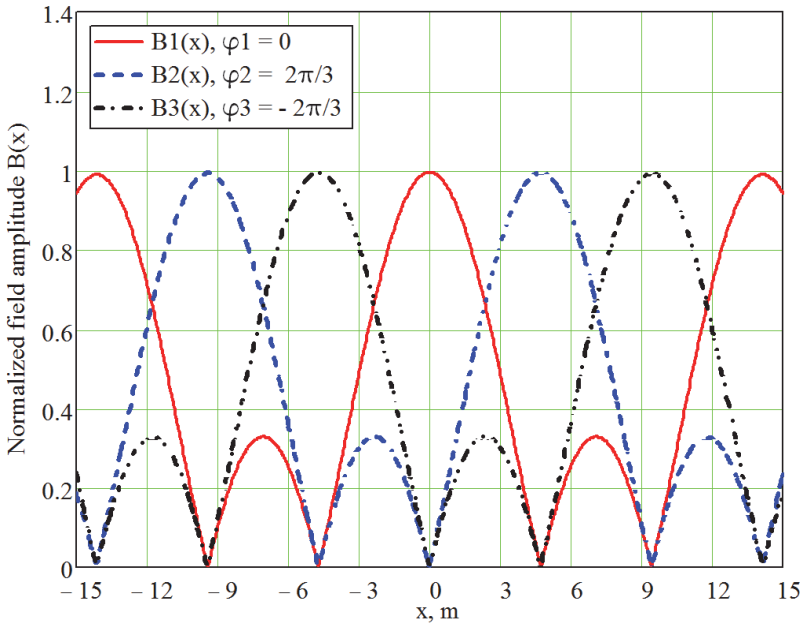

Fig. 9 – Distribution of the signal field amplitudes S_1 , S_2 and S_3 along the X -axis for the linear phase distribution law over the inputs of the PSAA for each signal with the parameters: $\varphi_1 = 0$, $\varphi_2 = 2\pi/3$, $\varphi_3 = -2\pi/3$.

To assess the efficiency of the separation of signals by the method proposed in this article, the ratio of S/N was estimated by both approximate methods and more accurate methods of numerical electrodynamics modeling for a different set of parameters L and d and equal amplitudes of signals at the PSAA inputs. As a result, the values of the S/N ratio lying in the range from (53 – 62) dB were obtained.

The dependence of the signal/(interference+noise) ratio at the input of the receiver on the parameters of the communication system with the separation of signals by CVF described in [13] was also studied in [7] using simulation. Studies were carried out for different combinations of parameters close to the values adopted in this article, in the construction of amplitude and phase distributions for interference fields. Studies have shown that the signal/(interference+noise) ratio after optimal spatial processing does not exceed the signal/noise ratio without spatial processing (one transmitting and one receiving antenna). Thus, when the signal/noise ratio is 40 dB, the signal/(interference+noise) ratio for different combinations of parameters lies in the range of 30...39 dB.

In the simulation in [7], the ratio of the interference power to the average noise power at the receiver input was assumed to be 10000: 1. Thus, in the sum of interference and noise, the latter does not play a significant role. The S/N ratio used in this article is determined at the input of the receiving antenna. At the output of the receiving antenna, i.e., at the input of the receiver, this ratio will be practically unchanged, since both useful signal and interference lie in the same frequency band and, after reflection from the PPAA, have practically the same wave-front shape of a spherical convergent wave. The above arguments allow comparing the values of the S/N ratio at the input of the receiving antenna, obtained in this work (53...62 dB), with the signal/(interference + noise) ratio obtained in [7] at the input of the receiver (30 ... 39 dB). As can be seen, the difference in these values is more than 20 dB, that is, in the case of the method of spatial separation of signals proposed in this paper, the discrimination of interference with respect to the signal is 20 dB stronger than in the method considered in [7, 13].

Concluding the discussion of the variant of the communication system with spatial separation of signals by CVF proposed in this article, we return to the question of a possible range of communication in such system.

The authors of [13], as already noted earlier, have indicated that the communication system proposed by them will effectively work only at distances ending in the intermediate zone. The reasons for this have also been discussed above. In the above pointed principles of operation of communication system discussed in this section, there are no factors related to the communication range. The efficiency of this system is determined by the possibility of forming the optimal structure of the interference field of the transmitted signals due to the adjustment of the amplitudes and phases of the signals at the inputs of the PSAA transmitting antennas. And this can always be achieved, i.e. at any range of communication.

However, the range of communication, without affecting the basic principles of the communication system, affects its practical implementation. With increasing range of communication, the interference structure of the field, shown in Figs. 5 – 9, retaining its shape stretches in both directions along the X -axis, and the coordinates of the extremum of the amplitude graphs increase in absolute value, which follows from (19). This leads to an increase in the size of the receiving antenna system along the X -axis, since the positions of the reflecting PPAA's are related to the coordinates of the zeroes of the amplitude of the interference signal fields. On the other hand, as follows from the same formula (19), an increase in the step L of the transmitting PSAA leads to the opposite effect – compression of the area of the interference field structure. Therefore, this effect can be used to reduce the size of the receiving antenna system. However, increasing the distance L at the same time it will increase the

size of the transmitting antenna system. In general, we can say that the communication range in the considered system is determined by the permissible sizes of the transmitting and receiving antenna systems – the larger these dimensions, the greater the possible communication range.

5 Conclusion

In this paper, a new method for communication systems of spatial separation of signals by CVF is proposed and investigated.

As a result of the research:

1) It is shown that for the realization of the proposed method it is necessary to form the optimal structure of the interference field in the plane of the opening of the linear reflective PPAA and to provide the reflection of the signal waves incident on the PPAA with their simultaneous focusing in the location of the aperture of the receiving antenna;

2) The concept of the optimal structure of the interference field is concretized, at which the maximum amplitude of the useful signal field coincides spatially with the zero of the amplitude of the interference signal, and the phase of the latter experiences a jump at the zero point of the amplitude by an angle close to π ;

3) It is established that the arrangement of the geometric center of the reflective focusing PPAA at the zero point of the amplitude of the interference field and the subsequent variation along the X - axis of the position of this center near the point of zero amplitude allows to find the position of the PPAA at which the maximum of the S/N ratio is attained. Maximization of this ratio is achieved mainly due to a significant suppression of the noise signal field and a certain increase in the useful signal due to the focusing of its field;

4) It is shown that based on the use of a vector model of the radio signal in a complex form and by analogy with the three-antenna PSAA to transmit N signals with their spatial separation by CVF, it is necessary to have a PSAA with no less than N transmitting antennas and N receiving antenna modules as part of the communication system.

The proposed system of communication with the spatial separation of signals by CVF provides the value of the S/N ratio by about 20 dB higher than the communication system described and investigated in [7, 13].

The use in the communication systems of the method of spatial separation of signals by CVF proposed in this work will allow simultaneously transmitting signals in one frequency band, one polarization and one direction, the maximum number of which is determined by the number of transmitting (and receiving) antennas, which allows to significantly increase the speed of information transfer preserving the information resources of the communication channel.

6 References

- [1] A. J. Fenn: *Adaptive Antennas and Phased Arrays for Radar and Communications*, Artech House, Boston, London, 2008.
- [2] A. P. Reutov: *Side-View Radar Stations*, Soviet Radio, Moscow, RF, 1970 (in Russian).
- [3] B. B. Malyutin, A. I. Okorochkov: Research of Dependence of Complex Coefficient of Reflection of Planar Diffraction Elements from Their Geometric Sizes, *Proceedings of the Nauchnaya Vesna-2017*, Shakhty, RF, April 2017, pp. 308 – 314 (in Russian).
- [4] D. M. Sazonov: *Antennas and Microwave Devices: Textbook for Radio Engineering Specialty of Colleges*, Vysshaya Shkola, Moscow, 1988.
- [5] E. V. Rogozhnikov, E. P. Voroshilin, A. S. Koldamov, A. A. Gelzer: Review of Ways to Improve the Performance of Radio-Relay Communication Lines, *Bulletin of the Siberian state University of Telecommunications and Informatics*, No. 4 (24), October 2013, pp. 3 – 11 (in Russian).
- [6] G. L. Khripkov, A. I. Okorochkov: Study the Differences in the Phase Characteristics of Radiation fields of the Two Antenna Systems in the Aperture Plane of the Reception Antenna Array, *Proceedings of the Nauchnaya Vesna-2017*, Shakhty, RF, April 2017, pp. 314 – 323 (in Russian).
- [7] H. L. Avdienko, Ye. A. Yakornov: Optimal Spatial Processing Effectiveness Indexes Calculation for Fixed Wireless Communication System Radiolink, *Visnyk NTUU KPI Seriiia - Radiotekhnika Radioaparotobuduvannia*, No. 52, April 2013, pp. 92 – 101 (in Russian).
- [8] I. Ya. Kremer, A. I. Kremer, V. M. Petrov, V. A. Pon'kin, N. A. Potapov: *Space-Time Signal Processing*, Radio and communication, Moscow, 1984 (in Russian).
- [9] R. A. Monzingo, T. U. Miller: *Adaptive Antenna Arrays. Introduction to the Theory*, Radio and communication, Moscow, 1986.
- [10] S. L. Koryakin-Chernyak: *Encyclopedia of Satellite Television, Science and Technology*, Saint Petersburg, 2010.
- [11] V. I. Slyusar: Correction of the Characteristics of the Receiving Channels of the Digital Antenna Array by a Test Source in the Near Zone, *Radioelectronics and Communications Systems*, Vol. 46, No. 1, January 2003, pp. 30 – 35.
- [12] V. V. Nikitchenko, S. N. Gladkikh, P. S. Vikhlyantsev: Analysis of the Possibility of Discrimination of Radio Emission Sources by the Curvature of the Wave Front, *Radioelectronics and Communications Systems*, No. 7, July 1988, pp. 58 – 60 (in Russian).
- [13] Ye. A. Yakornov, M. A. Kolomytsev, H. L. Avdieienko, O. Y. Lavrinenko: Theoretical Analysis of Possibility of Electromagnetic Wave Phase Front Curvature Physical Phenomenon Application in Stationary Microwave Radio Systems, *Visnyk NTUU KPI Seriiia - Radiotekhnika Radioaparotobuduvannia*, No. 48, March 2012, pp. 97 – 106 (in Russian).
- [14] Y. P. Serdyukov: *Methods and Algorithms for Processing Signals that Increase the Speed of Information Transfer*, Ph. D. Dissertation, Saint Petersburg University: SPBU, Saint Petersburg, RF, 2005 (in Russian).
- [15] Y. R. Zheng, R. A. Goubran, M. El-Tanany: Robust Near-Field Adaptive Beamforming with Distance Discrimination, *IEEE Transactions on Speech and Audio Processing*, Vol. 12, No. 5, September 2004, pp. 478 – 488.