

Tesla's High Voltage and High Frequency Generators with Oscillatory Circuits*

Jovan M. Cvetic¹

Abstract: The principles that represent the basics of the work of the high voltage and high frequency generator with oscillating circuits will be discussed. Until 1891, Tesla made and used mechanical generators with a large number of extruded poles for the frequencies up to about 20 kHz. The first electric generators based on a new principle of a weakly coupled oscillatory circuits he used for the wireless signal transmission, for the study of the discharges in vacuum tubes, the wireless energy transmission, for the production of the cathode rays, that is x-rays and other experiments. Aiming to transfer the signals and the energy to any point of the surface of the Earth, in the late of 19th century, he had discovered and later patented a new type of high frequency generator called a magnifying transmitter. He used it to examine the propagation of electromagnetic waves over the surface of the Earth in experiments in Colorado Springs in the period 1899-1900. Tesla observed the formation of standing electromagnetic waves on the surface of the Earth by measuring radiated electric field from distant lightning thunderstorm. He got the idea to generate the similar radiation to produce the standing waves. On the one hand, signal transmission, i.e. communication at great distances would be possible and on the other hand, with more powerful and with at least three magnifying transmitters the wireless transmission of energy without conductors at any point of the Earth surface could also be achieved. The discovery of the standing waves on the surface of the Earth and the invention of the magnifying transmitter he claimed his greatest inventions. Less than two years later, at the end of 1901, he designed and started to build a much stronger magnifying transmitter on Long Island near New York City (the Wardencllyffe tower) wishing to become a world telecommunication center. During the tower construction, he elaborated the plans for an even stronger transmitter based on new principles. Due to lack of the funds Tesla was forced to sell or to return the devices and apparatus, he gathered in the Wardencllyffe tower facility, which intended to use to operate the tower. He left the tower in 1907 and since then he was mainly engaged in inventions that were not directly related to the electrical engineering. The unfinished magnifying transmitter on Long Island was demolished in June 1917 by the American government.

Keywords: High frequency oscillators, High voltages, Antennas, Wirelles energy transmission, Electromagnetic compatibility.

¹School of Electrical Engineering, University of Belgrade, Bulevar kralja Aleksandra 73, 11020 Belgrade, Serbia; E-mail: cvetic_j@etf.rs

*This paper is dedicated to the anniversary of 160 years since the birth of Nikola Tesla

1 Introduction

Tesla began to use the first high voltage and high frequency electrical oscillators based on LC circuits around 1891. After years of working with high frequency alternators he concluded that, due to technical problems with arrangement of great number of magnetic poles in the stator and the increasing of the centrifugal force due to great angular speed of the rotor of the alternator, it is very difficult to generate frequencies over 20 kHz. He invented a new method of generating the high frequency currents using two loosely coupled LC circuits lately named Tesla transformer.

Using this approach, he was able to produce a much higher frequency of oscillations and the output voltages. In a series of patents in the nineties of the nineteenth century, this transformer was used as a basic part of almost every new high-frequency device. However, due to damped oscillations generated in TT he realized that its use is limited. To achieve the transmission of signals over long distances as well as for wireless energy transfer Tesla needed a source of continuous oscillation without damping. Therefore, he invented a transformer with extra coil which was first used in experiments in Colorado Springs 1899/1900.

During 1900/1901, he designed a new construction of the transformer and he began to build a large facility on Long Island about 70 km from New York. This transformer with an extra coil and with significant technical improvements is known as the Wardenclyffe tower. It was aimed at serving dual purposes with a great emission power. The output power was enough for the tower to become the world's telecommunications center and for wireless energy transmission.

Tesla's notes which he made during the construction of the Wardenclyffe tower show that his intention was to make later a new, stronger magnifying transmitter with an independent excitation which has a few important advantages.

2 Tesla Transformer (TT)

TT is a special type of transformer with air core. Tesla invented and used TT in his laboratory as a generator of high frequency (HF) and high voltage. The first patent of TT dates back to 1896, Fig. 1, although it is similar to the generators used since 1891/92, when he held the famous lectures first in America and then in Europe.

Later he used TT as part of other various patents. TT consists of two loosely coupled circuits consisting of the inductances (primary and secondary) and the capacitances in series. Primary coil has a small number of turns whereas the secondary has a large number turns. Since both circuits are in resonance

Tesla's High Voltage and High Frequency Generators with Oscillatory Circuits

with each other the capacitance are great on primary side and small on secondary. Electric schema is shown in Fig. 1.

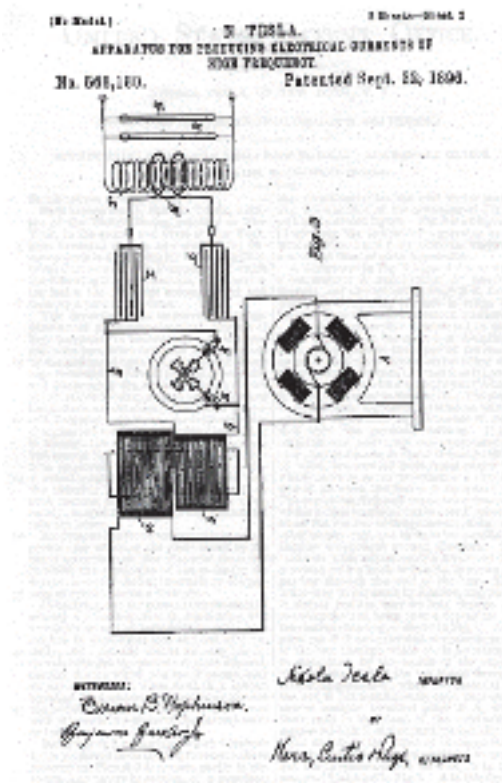

Fig. 1 – One of Tesla's patents of HF oscillator from 1896.

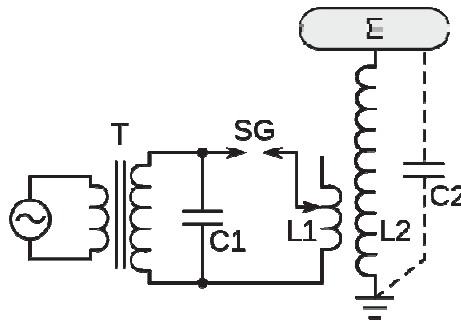

Fig. 2 – Basic electric shema of Tesla transformer.

The name that is used today has got in the early of 20th century, when many researchers in their laboratories used this transformer for experimentation. It is used to create the high voltages (up to 10 MV and over), generating frequencies of several tens kHz to over MHz.

TT power ranges from a few tens of watts (for demonstrative purposes) to several tens of kW (special effects). Tesla used it for different experiments with electric lighting with one or without wires, to create phosphorescence effect, for generating X-rays, for showing a variety of high-frequency phenomena in gases, electrotherapy, and wireless power transmission. TT has been used commercially in spark gap radio transmitters until the twenties of the 20th century. TT is now used mainly for educational purposes as well as for special effects in movies and theaters. Small TTs are used as a gas leak detectors in vacuum systems, initiators of the discharge, gas ionization and so on.

The first rigorous mathematical analysis of TT is performed by Oberbeck (Anton Oberbeck) in 1895 and Drude (Paul Drude) in 1904 and 1905. The exact theoretical analysis is only possible in the case of the circuits with no resistance and other effects that lead to losses (skin effect and proximity effect of the turns).

As afore-stated, the TT consists of two galvanic ally separated windings, primary and secondary, which are magnetically loosely coupled, Fig. 1. Tesla's original electric configuration comprises the high-voltage, low frequency transformer T (operating at network frequency inputting the energy in the system) a high-voltage capacitor C_1 , spark gap SG (stationary or rotary type) and the primary winding L_1 (a few of turns) on the primary side. The transformer has a large flux leakage (so to withstand the shorting of the transformer during operation). The secondary side consists of a long coil with a great number of turns. The configuration of these elements is shown in Fig. 1.

The winding L_1 (a few turns of thick wire, usually in the form of Archimedes' spiral enabling the maximum distance from the top of the secondary coil E), via the spark gap SG and the capacitor C_1 makes the primary circuit of TT. Secondary circuit of TT consists of the secondary winding L_2 (one-layer, densely wounded coil) and the secondary capacitance C_2 which is formed as the sum of internal capacitance of the coil L_2 and capacitance between the toroidal metal cap E on the top and the earth.

The way of working of this resonator transformer differs from ordinary network transformer although the physical law (Faraday's law) which is in the base of their work is the same. The network transformer works at industrial frequency (50 or 60 Hz) and it has well-coupled primary and secondary coils. Actually, one aims to realize the best possibly coupling of coils close to unity and therefore the transformer core is made of iron. As a result, the network transformer continuously transfers the energy from primary to secondary. The

TT works at thousands times higher frequencies compared to network transformer, due to heavy losses the iron core is not used, a coupling of the primary and secondary windings is only 20% or less. This slows down the transfer of energy between the primary and the secondary. The TT does not transfer the energy continuously, the energy being collected in the primary capacitor C_1 is transferred to the secondary capacitor C_2 in several oscillations. In order to achieve this, the oscillation in the primary and the secondary circuits must be tuned that is the primary and the secondary circuits must have the same resonant frequency. As the natural oscillating frequencies of both circuits are given by

$$f_1 = \frac{1}{2\pi\sqrt{L_1C_1}}, \quad f_2 = \frac{1}{2\pi\sqrt{L_2C_2}}, \quad (1)$$

where L_1 and L_2 are the inductances and C_1 and C_2 are the capacitances of the primary and the secondary circuits, respectively. It follows the condition for the tuning of the circuits ($f_1 = f_2$)

$$L_1C_1 = L_2C_2. \quad (2)$$

Due to the specific way of working, the voltage at the ends of the TT is not proportional to the ratio of numbers of turns of secondary and primary coils. The output voltage can be calculated from the energy conservation law neglecting ohmic losses. Input energy in the capacitor C_1 is equal to

$$E_1 = C_1 V_1 / 2, \quad (3)$$

where V_1 is the voltage on capacitor C_1 . As said previously, after some oscillations the energy on the upper end of the secondary coil of TT is

$$E_2 = C_2 V_2 / 2, \quad (4)$$

where V_2 is the output voltage on capacitor C_2 . If one neglects the losses in both coil turns this energy is equal the input energy ($E_1 = E_2$). Using already derived condition for resonant circuits, one obtains

$$V_2 = V_1 \sqrt{C_1 / C_2}. \quad (5)$$

Although it can be concluded from the last expression that the voltage on the secondary TT can be increased indefinitely by increasing the capacitance of the capacitor C_1 (or decreasing the capacitance of the capacitor C_2) this does not happen in the practice. Namely, the TT is usually designed in such a way that before achieving the maximum output voltage V_2 the breakdown in the air occurs (depending on the configuration of toroidal top metal caps E). The capacitor C_2 is discharged and the whole process of charging the capacitor C_2 is repeated closing the spark gap SG.

If the spark gap is static (with a constant distance between the electrodes) it closes (that is the breakdown occurs between the electrodes with the appearance of an arc) when the voltage on the capacitor reaches the breakdown voltage in the air, Fig. 1. The number of breaks is determined by the frequency of the supply voltage (the number of interruptions is two times higher than the frequency).

If the spark gap is of a rotary type, one set of the electrodes are usually placed on rotating disk approaching or moving away from other (stationary) set. The breakdown occurs when the electrodes are close enough and when the voltage is high enough. The number of interruptions is determined by the speed of the rotation of the motor, which carries the electrodes and the number of the electrodes. The number of breaks per second can be significantly greater than the network frequency.

The TT generates the damped quasi-periodic oscillations. It is a simple, inexpensive high-voltage, high-frequency source. The shortcoming of TT is limited possibility of independent changes of the amplitude of the output voltage and the operating frequency because these two parameters are interconnected.



Fig. 3 – *The TT manufactured at the School of Electrical Engineering in Belgrade in 2006. Output voltage is around 700 kV, working frequency is 100.5 kHz, power 2.5 kVA.*

In Fig. 3, the TT built in 2006 at the School of Electrical Engineering in Belgrade (in honor of the 150th anniversary of Tesla's birth) is shown. The primary coil is in the form of Archimedes' spiral while the secondary coil is densely wound, number of turns is 970, for 100.5 kHz operating frequency, the

length of the secondary wire is 746 m. The coil height is 1m with the diameter of 24.5 cm. The ratio of capacitance in the primary circuit and the total capacitance of the secondary is around 1000. The coefficient of coupling of the coils is around 0.2, the efficiency is 0.83.

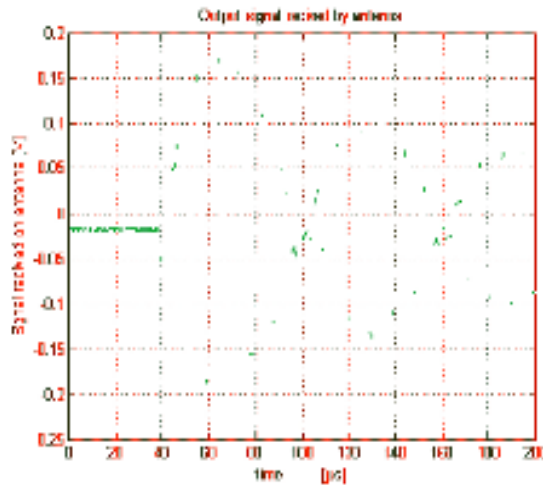

Fig. 4 – The time dependence of the output voltage on the secondary coil of the TT (discharge without sparks on the secondary capacitance). The amplitude-modulated shape of the secondary voltage can be seen (beating).

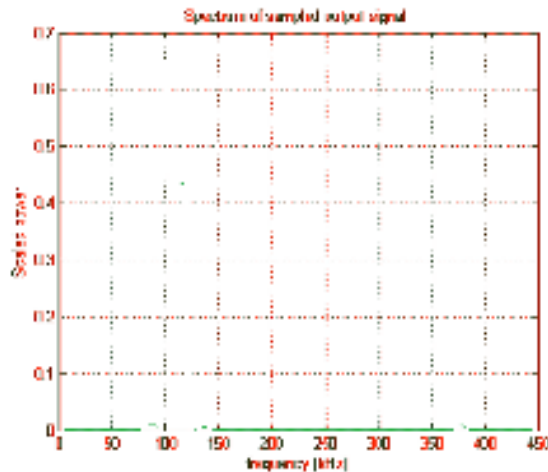

Fig. 5 – Spectral analysis of voltage on the secondary TT in accordance with the graphics of secondary voltage in the time domain, in Fig. 4. Three dominant frequencies 100.5 kHz, 116.9 kHz and 8.2 kHz can be observed. The greatest power in the spectrum is achieved at the frequency 100.5 kHz.



Fig. 6 – The TT made at the School of Electrical Engineering in Belgrade for the purpose of the opening ceremony of the 25th Summer Universiade 2009. Project leader Prof. Jovan Cvetić. Installation is attended by academician Prof. A. Marinčić, SANU gallery curator B. Božić and BSc. V.Malić. The total height of TT is 6m, while the length of the secondary coil is about 2m. The output voltage of 1.5 MV, the operating frequency is 52 kHz at input power of 10 kVA.



Fig. 7 – The discharges with the length of over 3m at the top of TT during the ignition of the University torch at the opening ceremony of the 25th Summer Universiade 2009 in Belgrade.

In Figs. 4 and 5 the voltages on the secondary coil in the time and frequency domain are shown. Due to the loose coupling of the primary and the secondary the modulated oscillations occur. In the real case of large output voltages, the discharge occurs at the maximum voltage in the first modulated period of the oscillation, Fig. 4. All the energy of the TT, stored in the secondary capacitance is discharged and spent on electromagnetic radiation and heat.

There are three dominant frequencies of oscillations, Fig 5. The calculation of the TT is done in accordance with the dominant frequency, in this case 100.5 kHz.

3 Tesla Transmitting Magnifier with a Special (extra) Coil (Colorado Springs 1899/1900)

Performing the experiments in his laboratory in New York during the nineties of the 19th century, Tesla is wirelessly transmitted signals at tens of kilometers using its transformer with loosely coupled coils generating damped oscillations. With this device he was able to transmit Morse code to several tens of kilometers or operate a simply device as he showed in 1897 demonstrating the control of wireless boat.

However, he realized that he needed a far greater power to transmit the signals at much greater distances. Besides, to transmit the voice and the images he needed a source of continual harmonic oscillations. Since he knew that the surface of the Earth is negatively charged (he measured the electric field on the surface of the earth of about 150 V/m, this value is known today as the electric field of fine weather), he came up with the idea to create the waves at its surface by to “get excited” the charges.

However, for these experiments he needed a large laboratory at a convenient location away from the city. He decided to build it in Colorado Springs, located at an altitude of about 2000 m, which has later turned out to be a very suitable place for the laboratory. Near his facility he has on his disposal a strong power plant where his three-phase system with 60 Hz was installed at the operating voltage of 550 V. During the 1899/1900 Tesla has designed and put into operation a huge laboratory in which he placed a new type of high-frequency transformer using the Westinghouse transformer of 50 kVA as a source.

The new high-frequency magnifying transmitter he designed and manufactured by himself, consisted of huge transformer with strongly coupled primary and secondary coils with the diameter of about 15 m and the special (extra) coil. As a power supply he used the capacitor banks. This magnifying transmitter is installed and put into operation in July 1899 in his laboratory in Colorado Springs. By conducting experiments with this device Tesla had not only confirmed that he was able to send the waves around the earth but he

discovered a number of other effects related to the atmospheric electrodynamics as well.

He was the first who detected the standing waves at very low frequencies (the lowest at about 7 Hz) caused by atmospheric discharges that are 50 years later again “discovered” and named after Schumann (Schumann resonances). His magnifying transmitter with special coil is both a waveguide in which the standing waves are formed and the lumped LC circuit. In contrast to the TT magnifying transmitter generates a continuous sinusoidal oscillation of a single frequency with very large voltage amplitudes, because the oscillations are increased by inserting the constant energy in the system.

A necessary condition for the creation of standing waves in a special coil is that the total length of the wire of the coil is equal or slightly less than a quarter of the wavelength of the waves that are generated. More particular capacitor discharges into the primary circuit of huge transformer at an exact instant of time charge a special coil increasing the amplitude of the standing waves in it. The maximum voltage is limited only by the breakdown voltage of the insulation and the dimensions of the coil.

Tesla had originally an intention to build, for a half a year in the lab in Colorado Springs, high power transmitter with continuous oscillations and to realize the transmission of signals over long distances. He secured about \$ 70,000 (currently around \$2,100,000) for the construction of the laboratory and the purchase or rental the equipment. The coils have been manufactured onsite; the wire for coils was purchased and sent by his assistant in New York.



Fig. 8 – *The exterior of Tesla's laboratory in Colorado Springs in 1899.
The dimensions of the wooden building are approximately 18×21 m.*

As can be seen from his notes he took almost every day in the form of diary, he was simultaneously developing a new systems of signal modulation in

aim to adapt the system later for more complex requirements that is for the transmission of sounds and images. In connection with the study of wireless transmission of energy he wanted to examine ways of the wave propagation over the surface of the Earth and in the atmosphere. However, during the experiments he has accidentally discovered (thanks to a strong and long-lasting thunderstorm with a lot of lightning in early July 1899) the existence of standing electromagnetic waves over the surface of the Earth. That gave him a new idea for the energy transmission without wires.

He modified his originally planned experiments to produce the standing waves. In the next few months, he studied the various conditions in which they are formed. His conclusion was that the frequency of the transmitter should not exceed 20 kHz for negligible wave attenuation.

4 Characteristics of Tesla Transmitting Magnifier with an Extra coil in Colorado Springs

How much this new high-frequency magnifier was ahead of its time is best illustrated by the technical data and the comparisons with then more or less similar devices for wireless signal transmission. Amperage at the top of the antenna was up to 1,000 A (the maximum current in the antenna around 1916 were 200 to 250 A). Generated voltages are reaching an average value of 3.5 to 4 MV (the maximum was up to 8 MV in some experiments), while the voltages of the antennas in 1916 went to a maximum of 30 kV.



Fig. 9 – *The interior of the laboratory in Colorado Springs in 1899. The part the high-frequency transformer with a diameter of 15 m (wound on the outside of the wooden fence) as well as the large extra coil (the far left) with several smaller ones can be seen. (Source: Popovic, Vojin, Nikola Tesla - From Colorado Springs to Long Island, Belgrade, Nikola Tesla Museum, 2008, p.302).*

The capacitance of the antenna of the transmitter was 550 to 660 pF, the average energy in particular pulses in the discharges was much over 50 kJ (1916 maximum of the energy of the pulse was about 10 kJ). The maximum length of the discharges at the globular top of the antenna (with the diameter of about 0.75 m) was about 30 m. This is proof of the existence of the standing waves on the surface of the Earth because only in this way he could achieve to get such long sparks. Otherwise, to produce such discharges without “help” of standing waves one needs a lot more power than the power he used.

5 Basic Electric Circuit Configuration in the Experiments in Colorado Springs

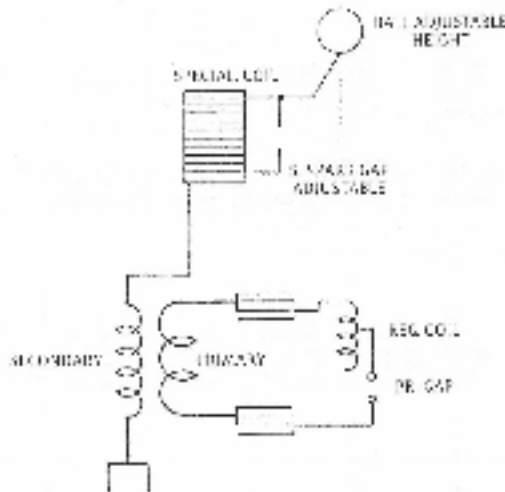

Fig. 10 – Basic electrical circuit diagram in the experiment on 5 October 1899 in a laboratory in Colorado Springs, which was used for the determination of the conditions for the formation of standing waves in a special coil (Source: Popovic, Vojin, *Nikola Tesla - From Colorado Springs to Long Island*, Belgrade, Nikola Tesla Museum, 2008, p.203).

Basic electrical circuit diagram is shown in Fig. 10. The primary and the secondary of the large high-frequency transformer are strongly coupled (ideal transformer). This is easily achieved by Tesla using the large size of the transformer (the diameter of coils were around 15 m). Since the primary and the secondary turns are wound with the same diameter and placed closely side-by-side (therefore the surfaces of both coils are practically the same), the coupling coefficient is approximately equal to 1. Transformation ratio is greater than 1:10.

The primary circuit consists of one or two turns in parallel. Special (extra) coil is placed vertically in the center of the great high-frequency transformer. It is connected with the transformer with its lower end. The upper end of the special coil is connected with the elevated vertical antenna above. Although the special coil as well as other various special coils is placed within 15 m radius of the transformer, Fig. 9, they are not affected by the current in the primary and the secondary. This is due to the strong coupling of the coils resulting with zero magnetic flux within the transformer.

To generate the oscillations in the primary circuit consisting of the primary coil, the large bank of capacitors and the rotary spark gap (constructed as a motorized breakwheel), he had to provide an additional variable inductance (choke), Fig. 10. The oscillations in the special coil are correlated with the oscillations of the primary circuit in the manner as explained in the case of TT. Inner capacitance of the special coil together with the capacitance of the antenna gives the total capacitance of the special coil. The current in the special coil oscillates freely, with very small damping.

The rotation of the breakwheel interrupts the current in the primary coil. These interruptions are synchronized with the oscillation in the special coil. Local water supply network and special buried plates are used as the grounding electrode. The only thing Tesla complained in Colorado Springs was the rocky soil which is not suitable for good grounding necessary for the proper operation of the magnifying transmitter. After several months of hard work testing different combinations of the circuits for signal transmission, on 5th October 1899 he made the best configuration with the following elements, Fig. 10.

6 Power Source

To input the power into the primary of the high frequency transformer, Tesla used Westinghouse transformer with a great leakage (it could operate in short-circuit mode) with oil insulation. This transformer is made in Westinghouse factory previously according to his calculations. The input voltage of the transformer was 200/220 V for continuous power of 50 kVA and the network frequency of 60 Hz. The output voltage was up to 40 kV.

7 High Frequency Transformer

Part of this transformer can be seen in Figs. 9 and 11. The diameter of the coil of the transformer is about 15 m. The primary coil consists of two turns which can be connected in series or in parallel (each consisting of a bundle of 37 copper wires No.9 AWG, with the cross section of 2.9 mm^2 each, insulated with the rubber and braided). Secondary coil had up to 48 turns; it consisted of a bundle of copper wires No. 10 AWG, with the cross section of 2.6 mm^2 each. The total number of turns of the secondary coil depends on the transformation

ratio. The number of wires in the bundle of the secondary coil was determined so that the primary and secondary coil has the same mass of copper. This condition is now known as the adjustment of impedances to achieve the maximum transmitted power. Tesla was the first to notice that the ohmic resistance of the coil considerably increases in the circuits with high frequencies due to the skin effect in conductors. He suggested the solution in a form of the bundle of insulated wires instead of one solid wire.

Above the upper edge of wooden fence of the body of the transformer the grounded cable is hitched on the insulating stands, Fig. 9. In its characteristics this transformer is similar to what is known as the "ideal" transformer, with no leakage magnetic flux. Due to the large and approximately the same diameter (coils are wound vertically one above the other) the primary and secondary coils are strongly coupled (that is the coupling coefficient is equal one) and the leakage flux is negligible. Therefore, the transformer does not create the magnetic flux inside the coils during the operation. It turns out that it does not affect the operation of other coils or devices inside the coil; they can be put inside at will. Transformation ratio is greater than 1:10.

8 The Bank of Capacitors

The bank of capacitors is connected to the primary coil of the high-frequency transformer via a rotating spark gap, Fig. 10. They were made in the form of parallel-serial connection of elementary capacitors, Fig. 11.

It is interesting to note that Tesla used bottles of whiskey with green and dark glass filled with a solution of rock salt for the elementary capacitors. One electrode passed through an insulator plug and it was dipped into the solution inside the bottle, the second electrode was a metal container with a solution of rock salt in which the bottles are dipped. For that time it was a brilliant and cheap engineering solution. On the one hand good high voltage capacitors were rare and expensive; on the other hand the glass is a very good insulator with small dielectric losses. The bottles are easy to connect (or to change if broken), and the total capacitance is simple to calculate. Since he needed greater values of capacitances, Tesla connected elementary capacitors in parallel by sinking three bottles in the same solution in a common metal box. This comprised one elementary capacitor bank. He connected a certain number of elementary banks in parallel and (or) in series to achieve the necessary voltage and the total capacitance, Fig. 11. He had on disposal two types of bottles with various volumes. The small bottles had a capacitance of 1.06 nF whereas the bigger had 3 nF. The maximum permissible voltage for both types was about 22.5 kV.



Fig. 11 – *The bank of capacitors for the primary circuit for high frequency transformers in Colorado Springs in 1899. In the background, one can see the variable inductance coil. (Source: Popovic, Vojin, Nikola Tesla - From Colorado Springs to Long Island, Belgrade, Nikola Tesla Museum, 2008, p.302).*

9 Antenna

Tesla made the antenna from several segments in order to set it up in vertical position and raise it up to necessary height. It was composed of six steel tubes and antenna carrier that were inserted into each other thereby enabling antenna length change, in Fig. 12. The height of cylindrical steel antenna of medium diameter comprising around 25 cm totaled 51 m with brass ball at the top the diameter of which was 0.75 m. The antenna carrier is the square beam made of wood of the fir (30×30 cm) the length of which is 6 m.

The antenna is short if compared with wavelength of electromagnetic waves created by a high-frequency transformer. Its length equals the total amount of about 1-2% of wavelength thereby poorly radiating space waves. This antenna can primarily be considered as capacitance at the end of additional coil aimed at its “electric shortage” and creating standing waves. As Tesla himself claimed, he tried to render any spatial radiation at the minimum by “Hertzian” waves, which, according to his opinion, were unfavorable even for signal transfer let alone the energy. Namely, its power decreases inversely proportionally to the square of its distance, while Tesla wanted to create surface waves the power of which would decrease inversely proportionally to the distance thereby setting up a larger scope. Therefore, the antenna in Colorado Springs, in fact, represents

the capacitor with changing capacitance depending on its length above surface. Capacitance is adjusted so as to create the existing waves in special coil with maximum voltage at the top of the coil, i.e. in the antenna. Brass ball on the top prevents creating corona and discharge in spark form that disrupt the occurrence of simple periodic continuous antenna oscillations.



Fig. 12 – The construction and the dimensions (the diameters are given in inches) of steel antenna in experiments in Colorado Springs, the lower part of the pole (antenna carrier) is the wooden beam (Source: Popovic Vojin, Nikola Tesla – From Colorado Springs to Long Island. Belgrade: The Nikola Tesla Museum, 2008, p.187).

10 Spark Gaps

In Colorado Springs notes, no detailed data on constructing spark gaps were provided. From earlier, Tesla had the stationary spark gaps constructed (both with pneumatic and magnetic arc blow) and rotating switches with quicksilver for high-power electricity that he himself had designed and utilized in his New York laboratory during a sequence of years. He transferred those

spark gaps temporarily to the Colorado Springs laboratory. The maximum number of switches per second that he could achieve was sixty thousand with two switches, which turned in opposite directions.

11 Special (extra) Coil

While the TT secondary is modeled by inductivity and internal capacitance, and the wave properties are less distinct due to dense coils, a special additional coil represents a wave resonator, which has to be modeled with distributed parameters, longitudinal inductivity and longitudinal capacitance both within the coil and ground. Within the coil, there are resonant frequencies depending on its geometry and position in relation to other surrounding objects thereby rendering calculation and measurement more complicated.

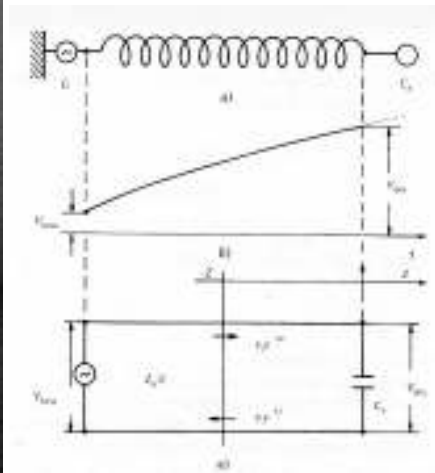
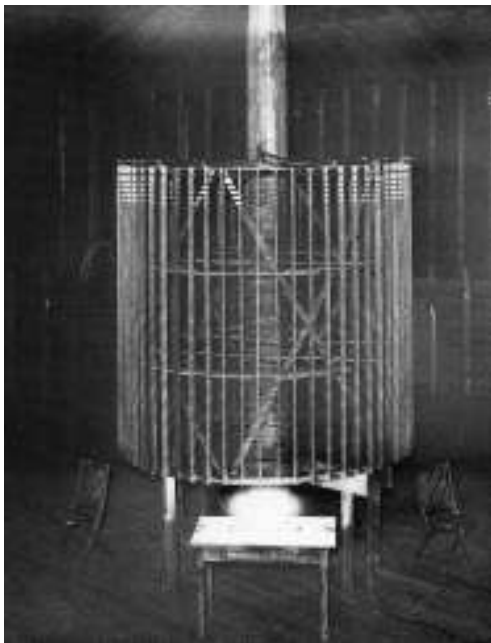

Fig. 13 – *Special (extra) coil representing waveguide that is closed from the upper side by capacitance (the so-called shortened waveguide), while it is powered from the secondary of high-frequency transformer in its basis. The wire length is about 10% smaller than the quarter of the wavelength. (Source: Popovic Vojin, Nikola Tesla – From Colorado Springs to Long Island. Belgrade: The Nikola Tesla Museum, 2008, 340, p.336 and p.439).*

The huge coil is in the center of laboratory, was used by Tesla as a special coil for creating voltage greater than 8 MV (Fig. 13), and had approximately the same height and diameter. It is known that coils dimensioned in such a way

have the maximum low frequency inductivity and the minimum individual capacitance, which considerably simplified the manner in which Tesla made calculation and measurement. However, this geometry does not represent an optimal solution. Namely, in the patent application that was submitted several years later, Fig. 16, he drew somewhat differently dimensioned narrow special coil with substantially higher length than in the case of diameter length. This coil represents a better solution (several such smaller coils can be seen in the laboratory, in Fig. 9) because the coil top (which is of the highest potential) is being made distant, while its lower part is grounded thereby preventing discharge and enabling the coil to reach higher potential. Probably the laboratory roof height limited this optimal solution, and therefore, Tesla made a coil in accordance with available space. The diameter and height of the special coil are 2.5 m, with approximately 100 rarely wound coils, the coil being No.6 AWG 13.3 mm², and continuous current being 75 A (or 670 A to 10 s), the total wire length comprised 790 m, the resonant wavelength of the wave totaled 3.16 km (for a wire length equal to a quarter of the wavelength), the resonant frequency being 95 kHz. Tesla made measurements of inductivity of the coil and found that it equaled 18 mH, and then, he calculated the resonant frequency of 86.8 kHz and wavelength of 3.46 km. He obtained the wire length as the one that was smaller than a quarter of the wavelength for approximately 10%.

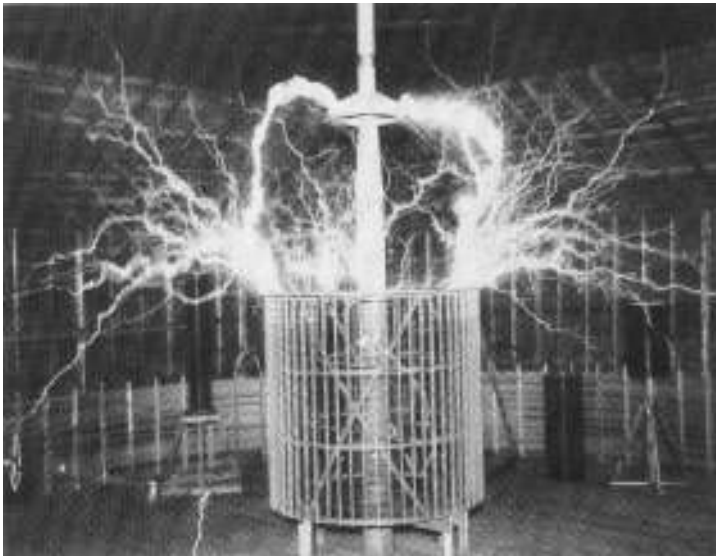

Fig. 14 – *The special coil during the Colorado Springs experiment in 1899. Discharge between the coil top and the basis of an antenna metal part is visible. (Popovic Vojin, Nikola Tesla – From Colorado Springs to Long Island. Belgrade: The Nikola Tesla Museum, 2008, p.354).*

It can be seen in Fig. 13 that coils on the top of the special coil are reduced because Tesla probably adjusted the optimal coil length at the very spot (so as to avoid rewinding up the whole coil now with different space) in order to form the standing wave, that is, reach the coil top maximum voltage. Since physical space enlargement entails wave phase speed increase on coil top, fine adjustment is being made, i.e. “shortening” of the coil wire length. Figs. 14 and 15 display the special coil operation in resonance setting. Tesla achieved voltage up to 8 MV with ease in his Colorado Springs laboratory. Utilizing earth resonance, he achieved discharge above 30 m.

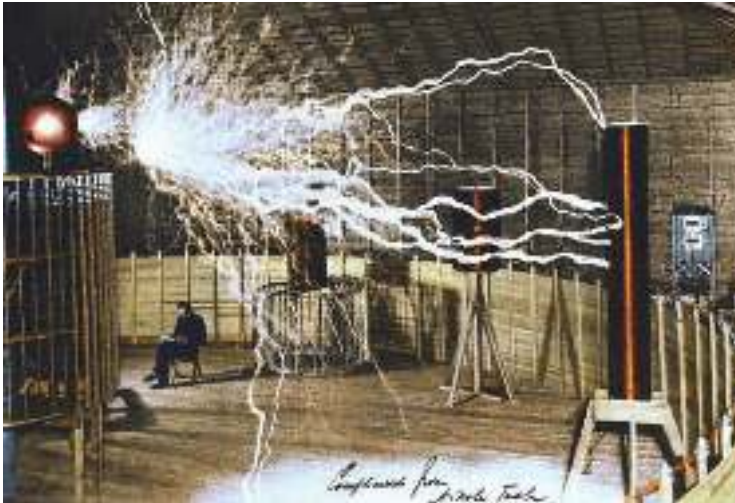

Fig. 15 – *Electric discharge of approximately 7 m length with special coil in the laboratory center in Colorado Springs in 1899. The picture was made by means of double exposition so as to depict Tesla as being in the rear of discharge. Both special and right-hand narrow coils are in resonance.*

12 Tesla Magnifying Transmitter – Wardencllyffe Tower (1901-1917)

Having completed the Colorado Springs experiment in January in 1900, Tesla returned to his New York laboratory where he put his notes in order, gave new calculations and worked out new ideas. During 1900/01, he was looking for donators for his magnifying transmitter of considerably greater power than the experimental facility in Colorado Springs. In his New York laboratory, he also conducted significant experiments and calculations for a future transmitter in Wardencllyffe and for various types of sensitive receivers. It is during this period, in December in 1901, that his ex-associate and currently his rival in wireless telegraphy development, Guglielmo Marconi succeeded in transmitting the first signal across the Atlantic. Tesla, being aware of the fact that Marconi

utilized his patents in order to enable wireless transmission, hurried up to find someone interested enough to invest in wireless telegraphy development in the manner that was conceived by him. He succeeded in obtaining the contract with a famous rich man and industrial businessman J. P. Morgan, from whom he obtained \$150,000 (which is approximately 4.5 millions of dollars nowadays) in order to construct the large receiver for world communication. By the end of 1901, the construction of magnifying transmitter took place. This transmitter was called Wardencllyffe Tower according to the owner of the 30 hectare land Tesla had previously rented. Essentially, this tower is the same version (with smaller changes in the form of its dome) of a special coil transformer utilized in Colorado Springs experiments, but was envisaged to reach considerably higher power. Tesla filed in the patent no. 1,119,732 in the beginning of 1902 (which was only approved in 1914), Fig. 16. According to Tesla's patent, the maximum voltage on the dome is about 30 MV. In addition to signal transfer, the transmitter should also serve the purpose of electrical power wireless transmission the power of which is 10 MW. He hid this lastly mentioned purpose of the tower from J. P. Morgan, because the latter approved of the funds only for telecommunication purposes. When he ran out of funds, Tesla desperately required additional investment from J. P. Morgan as he had previously revealed completely his intention.

The tower was constructed up to 1904, and J. P. Morgan rejected Tesla's request in the arrogant manner to invest additional means for finishing the tower off. It sounds paradoxical, but J. P. Morgan, who was a passionate collector of paintings and sculptures, that immediately after signing up the contract with Tesla in March in 1901, only a month later bought an art painting by Thomas Gainsborough for an identical sum (of \$150,000). Several months later, he spent almost three times higher sum (of \$400,000) for one sculpture made by Raffaello, and then made a donation of \$1 million to the Harvard Medical School for constructing three buildings.

Tesla himself collected some additional funds through friends and even family members. According to Tesla's own words as a court witness in 1916, he spent about \$500,000 in total (which is equivalent to today's \$15,000,000). A huge part of these funds had been spent for renting the equipment, estate and wages for workers. Additional difficulty for Tesla in this period was economic depression with unstable market prices (it seems absurd that J. P. Morgan himself, while striving for new markets, was one of the greatest bankers and shareholders of the time thereby being one of the main protagonists of constant changes in prices of basic industrial raw materials). Nevertheless, the transmitter had remained unfinished, i.e. without its dome. The tower height totaled 57 m, and was made in the form of the octagonal wooden grid construction with replaceable elements and steel connection plates. The design for this tower was made by a famous designer, Stanford White, who was also a

Tesla's High Voltage and High Frequency Generators with Oscillatory Circuits

Tesla's personal friend. The building-laboratory was constructed in vicinity of the tower of about 60 m. It contained various equipment, workshop and steam engine generator the power of which equaled 300 kVA for supplying energy for the tower.

N. TESLA.
 APPARATUS FOR TRANSMITTING ELECTRICAL ENERGY.
 APPLICATION FILED JAN. 19, 1902. RENEWED MAY 6, 1907.
 1,119,732. Patented Dec. 1, 1914.

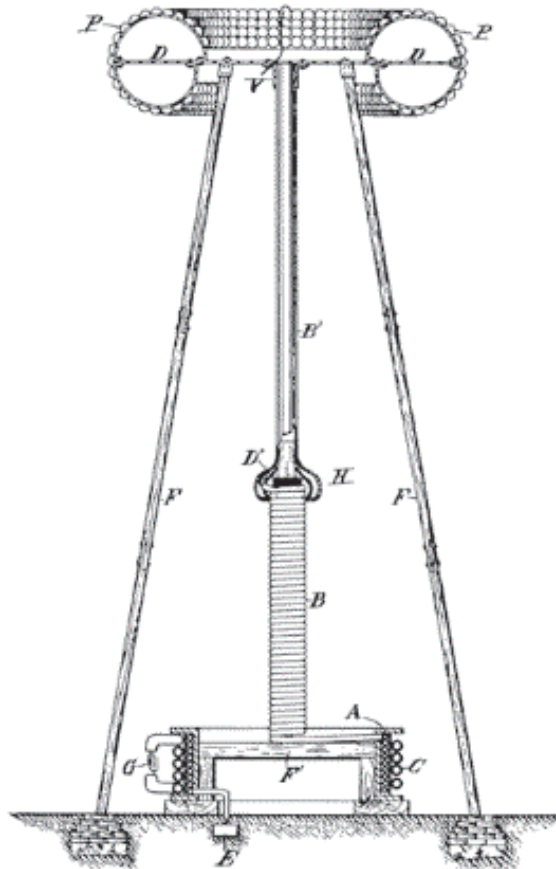

WITNESSES:
W. Lawson Gynn
Benjamin Miller

Nikola Tesla, INVENTOR,
 BY *Kear, Page & Cooper*
 his ATTORNEYS.

Fig. 16 – Patent no. 1,119,732 „The apparatus for electrical energy transfer“, 1902/1914.



Fig. 17 – *The Wardencllyffe Tower (Long Island) at the beginning of 1902 with the dome platform. The laboratory building had been constructed next to the tower.*

As a court witness in 1916, Tesla revealed that the distance of 60 m represented the minimum distance that according to his evaluation would not lead to discharge between the dome and the laboratory chimney given the fact that he had foreseen generating high potential on the dome.

The tower top was meant to provide setting up the spherical conductive dome made of copper tin whose diameter totaled 20.7 m, and whose mass equaled 55 t. The internal construction of the dome was made of steel. The dome represented the necessary capacitance for creating stationary waves in the special coil and on the Earth's surface. The tower wooden construction should have provided regular operation, because too large quantity of steel elements would disrupt the normal operation. In order to increase the tower's own capacitance, Tesla had envisaged setting up 30 hemispheres on the dome. It is interesting to notice that similar solution with hemispheres was shown in the patent in Fig. 16. However, in Long Island transmitter he abandoned the thoroidal structure of the dome and opted for the spherical one so as to increase the capacitance and the potential to the maximum extent. On the other hand, he ascertained that the dome capacitance toward the Earth should be as small as possible (in order to achieve such an effect the best solution is to utilize a sphere

structure accompanied by a simultaneous minimum field magnitude of its surface) in relation to its own capacitance (of the lonely sphere) so that the transmitter would “pump the disconnected” charges in the Earth.



Fig. 18 – *The Wardencllyffe Tower (Long Island) in 1903 with steel ribs without copper covering.*

The dome was distant to the maximum extent from a special coil below in order to prevent its influence on forming the standing waves in it. Tesla calculated the total capacitance of the dome as being 10 nF. Contrary to previous patents for wireless signal transmission based on radiation of antenna, in this case Tesla wanted to prevent the tower radiation as much as possible and increase energy transmitter inserted in the earth through the ground.

Tesla knew that good tower grounding of paramount significance for creating standing waves on earth. Without quality electric connection of the tower and ground, the tower basis current generates great losses and it attenuates thereby rendering the system inefficient. This is the reason why during the tower construction he dedicated more time to underground works concerning grounding than the tower works above ground. He spent more than a half of approved funds for creating a vertical tunnel (whose diameter was 4 m with helicoidal stairs, and the depth totaled 30 m) and digging in grounding (16

steel ground wires horizontally and radially distributed into the soil, Fig. 19). He probably had to dig the vertical tunnel because while digging in the grounding at around 30 m of depth he found a water layer that made him dig the tunnel up to it and additional four tunnels toward the surface.

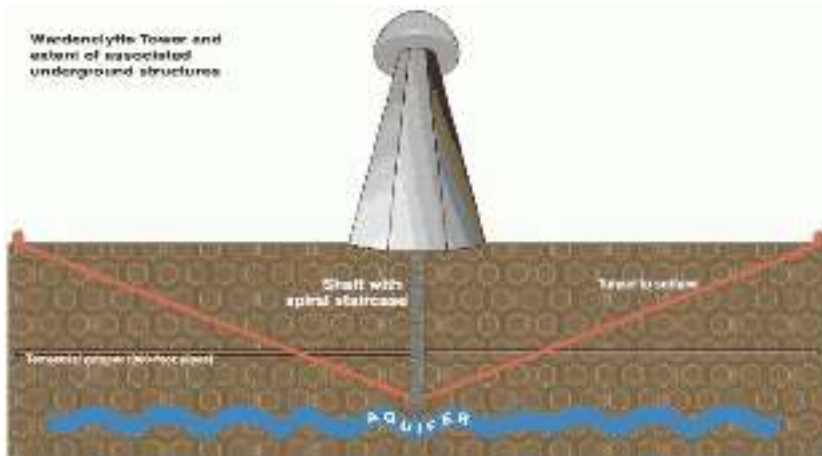

Fig. 19 – Tunnels below the tower most likely served for diverting steam, which was created in the ground due to high currents.

The purpose of these tunnels is probably transporting the generated vapor in grounding. Namely, heat loss created in grounding would be so high even in the case of very good grounding. For example, if the grounding resistance equals 1Ω , and the grounding current equals 1 kA (anyhow, Tesla foresaw currents up to 4 kA) grounding loss would amount to 1 MW ! These were predominantly located at a relatively small contact surface of grounding and ground. In contact with water, this power would create huge quantity of steam as well as pressure below ground, which would set up the tower foundations thereby jeopardizing its stability.

In addition to the office, laboratories, workshops and ancillary rooms with steam machine and generator, coal storage, oil reservoirs and air tanks under pressure were made in the building next to the tower. Even though the tower had never been finished, Tesla conducted some experiments with the equipment he had. He performed measurement and adjustment up to 1907. His notes contain calculations for inducing the transmitter in several ways, Fig. 21. The predicted version of the Wardenclyffe tower is identical in its scheme with the transmitter in Colorado Springs, according to the pattern in Fig. 16, and the excitation is depicted in Fig. 21a).

Tesla's High Voltage and High Frequency Generators with Oscillatory Circuits



Fig. 20 – *The view of the interior of the building-laboratory in Wardenclyffe, in 1903. Above: the room for experiments. Below: the workshop with lathes and tools.*

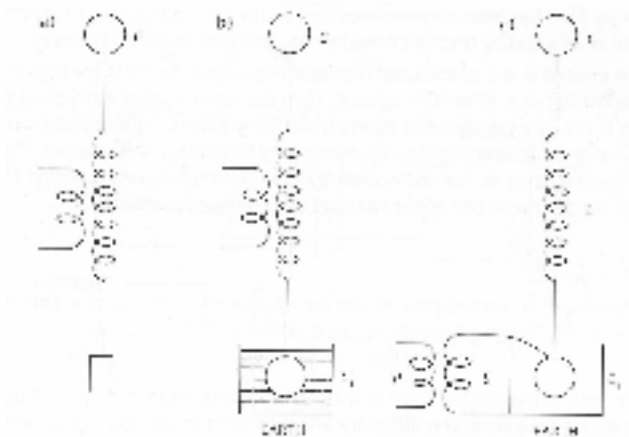

Fig. 21 – Different types of transmitter excitation in Wardenclyffe:

- a) Direct galvanic connection with ground through the dug in grounding
- b) Indirect capacitance excitation through the dug in and insulated ball.
- c) Combined excitation.

(Source: Popovic Vojin, Nikola Tesla – From Colorado Springs to Long Island. Belgrade: The Nikola Tesla Museum, 2008, p.487).

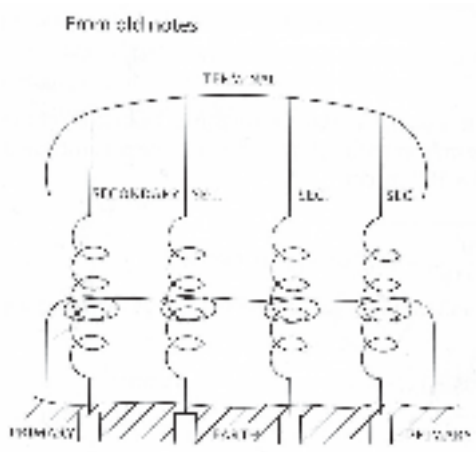

Fig. 22 – The complex excitation of Wardenclyffe transmitter for enabling both multichannel protection transmission and energy through generating complex waves (Source: Popovic Vojin, Nikola Tesla – From Colorado Springs to Long Island. Belgrade: The Nikola Tesla Museum, 2008, p.487).

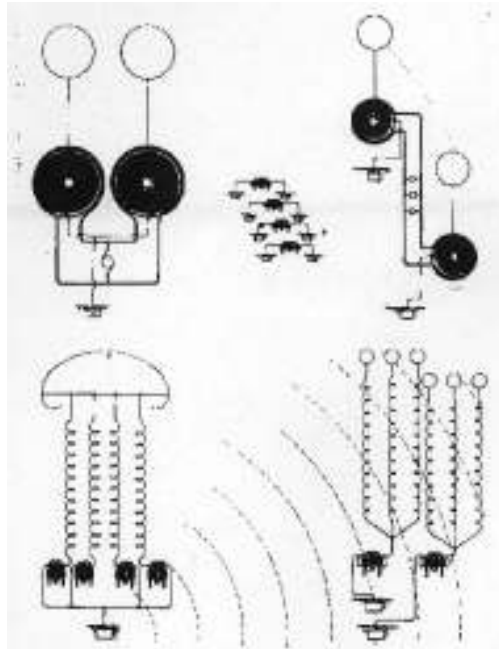

Fig. 23 – *The outline of the signal transmitter and receiver from Tesla's uncompleted patent submission (most probably due to the unfinished transmitter in Wardencllyffe). The upper pictures: two coupled circuits transmitting the complex signal by means of "Hertzian" waves connected to the earth's ground. This outline was probably drawn for the sake of comparison with a new means of signal transmission in the pictures below. They were also put in order with the selective receiver. Lower pictures: the transmitter with four special coils (Wardencllyffe Tower) and receivers with three coils each for selective "current through ground" (Source: with the courtesy of The Nikola Tesla Museum in Belgrade).*

In order to transmit the signal, Tesla envisaged the multichannel protection transmission through four special coils in transmitter and three coils in parallel in the receiver, Figs. 22 and 23. It is seen that all special coils are excited by one primary coil and its current because they are connected in a series while special coils are connected in a parallel (for a dome and grounding). Each of coils in a series with the dome generates its own characteristic oscillation frequency. Coils probably do not have the same number of wires so that these characteristics differ. There are diverse magnetic couplings between coils (of the mutual inductivity) so that the basic frequency number rendering transmitter oscillation increases. This is clearly seen in Fig. 23 (the outline of Tesla's uncompleted and unrealized patent submission probably due to the unfinished tower) where the lower part of the picture displays the protected transmission principle by means of his "current through ground" system.

The right receivers have three coils each with independent top capacitance. Only those coils are excited that oscillate with one of characteristic frequencies of the left transmitters. The signal is transmitted only if all three coils are excited, i.e. if they are resonant with the transmitter. The second receiver has coils adjusted to different resonant frequencies (it is sufficient that only one of them differs) so that it cannot receive the signal that is received by the first receiver. If receiver coil directions are carefully observed, it is seen that two left ones and two right ones are wound in the opposite manner. Tesla did not draw this incidentally and has to do with super-magnifying transmitter that he conceived of and wanted to construct later by introducing some smaller changes to the designed magnifying transmitter at Wardenclyffe Tower. It should be stated that Tesla had noticed significantly larger signal transmission efficiency by means of “currents through ground” in Colorado Springs, and subsequently concluded that it had to be of long range since waves are not dissipated in space. The protected signal transmission from earlier Tesla’s patent submissions is depicted in the upper part of Fig. 23. These are transmitters with so called ground waves with characteristic coils in the form of Archimedes’ spiral in the lower antenna part (which, otherwise stood vertically as in the Figure, because of minimum capacitance toward the ground). The upper antenna part is in electric terms “shortened” by capacitance, and serves for reducing losses due to antenna top sparks. Receivers are of similar construction as well as transmitters, but can be totally different: in the form of coils between two distant ground points (displayed in the middle of the upper part of Fig. 23). This was already patented and utilized by Tesla, and the range comprised several tens of kilometers with transmitting power of several tens of kilowatts since the antennas used in experiments were short in electric terms and thus inefficient (a vertical length of the straight grounded antenna of the quarter of wavelength is necessary in order to obtain efficient). Probably, due to comparison with the new transmission system Tesla drew then known and utilized systems so as to point out advantages and means of utilization.

The magnifying transmitter in Wardenclyffe also had a “secret” function, i.e. wireless energy transmission. After discovery of standing waves and research in Colorado Springs, Tesla kept this function in secret even from his financier J. P. Morgan. Reasons for this are probably manifold, but it was evident that during Tesla's life the principles of the device he had described in his patent were utilized under different name or in ostensibly different form without mentioning Tesla's patents. The last such case was signal transmission across the Atlantic in December 1901 on the part of Marconi, who had used up Tesla's four resonant coil principle, which is displayed in Fig. 23 (of the upper outline). The patent that had been filed by Marconi only in 1904 did not represent the four resonant coil principle and as such could not function and

fulfill transmission². This was revealed by Tesla while he witnessed at a trial in 1916. The second reason was probably the fact that Tesla estimated that the businessman J. P. Morgan would not like the idea of uncontrolled use of wireless energy without charging it. Although historians of science highlight this as the main reason why J. P. Morgan refused to further finance the Wardencliff transmitter, technically speaking, this was an exaggerated statement. Namely, Tesla was aware of the fact that due to efficient use of energy it cannot be evenly distributed but can be rather concentrated in certain narrow areas. Thus, in some Earth's parts, there would not be energy or its surface concentration would be small. On the other hand, even in areas with high concentration of surface energy transmitters (wires, loops, towers) would have to cover the surfaces of at least several tens of square kilometers, which practically excludes the possibility of its uncontrolled usage.

In order to collect energy in smaller concentrated circles at Earth's surface for wireless energy transmission, Tesla envisaged generating the resultant standing wave that is obtained by emitting of at least two waves of similar frequencies at the transmitter point *T* and their reflection from the antipode point *P*, Fig. 24.

For precisely determined transmitter frequencies, a wave is reflected from the antipode point *P* (according to Tesla, as in the case of the conductor open end) and a standing wave is being formed across the Earth's surface. In physics,

²Guglielmo Marconi, patent no. 763.772, „Apparatus for Wireless Telegraphy“ (“Apparatus for wireless telegraphy”), 1904. The history of this patent is interesting. It was submitted in 1900, but the officer in the patent bureau knew previously about Tesla's patents as well as patents of other researchers connected with wireless transmission O. Lodge, M. Pupin, J. Stone and persistently refused to accept Marconi's patent submission. It was only when he retired in 1905 that the other officer accepted Marconi's patent submission. Anyway, even in 1900 the issue of signal transmission was not the question of physics principles. Tesla patented an invention of the wireless signal transmission principle several years before the official date of the signal transmission across the Atlantic (more precisely, 12th December 1901), and it was only the device power that made impossible for him to carry out the long distance transmission. At the time, it was very expensive to provide for powerful generators for device supply. Above all, Marconi was a businessman and had enough financial funds to provide for 30 kVA generators. That was the reason why he succeeded in sending the signal at the distance of around 3500 km. In his New York laboratory experiments, Tesla did not exceed powers of several kW per transmitter, and even the supply transformer in Colorado Springs was around 50 kVA. However, even then Tesla did not use antenna radiation principles, which he had patented before. On the contrary, he explored other principles of signal transmission and had different goals, and deliberately by transmitter coil construction he disabled the radiation of “Hertzian waves” and generated “current through ground”.

this is known as a standing wave of a wave group, and is defined by the spatially modulated amplitude (envelope). The areas of the surface energy maximum are designated by lines. The width of these areas (represented by lines) is one half of the wavelength.

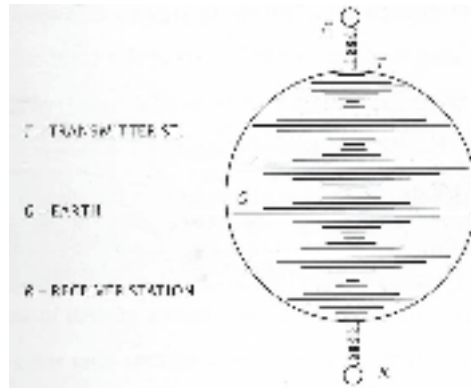

Fig. 24 – Tesla's drawing from notes, 2nd June 1901. Formation of a standing wave across the Earth's surface with the modulated amplitude for wireless energy transmission from the transmitter station T to the receiver station R. The point of maximum energy density across the surface are the longest ones from the horizontal line. (Source: Popovic Vojin, Nikola Tesla – From Colorado Springs to Long Island. Belgrade: The Nikola Tesla Museum, 2008, p.501).

Generating wave groups comprising two or more waves of similar frequencies is plausible with transmitter configuration in Fig. 23 (the lower outline). However, this transmitter configuration does not permit fine frequency regulation, which is necessary for precise adjustment of a standing wave. Due to this, Tesla invented new configuration of the magnifying transmitter with independent excitation, Fig. 26, which will be discussed in next chapter. In order to concentrate energy across the surface to a large extent, Tesla also invented the other means of system operation. He proposed setting up three transmitters spatially moved for one third of a circle, Fig. 25 (the outline from the unpublished patent submission, without explanation) that operate at the identical but precisely defined frequency. Broken lines in Fig. 25 represent the most likely standing wave maximum. Surface energy density increases considerably in triangular surfaces, and decreases in hexagonal surfaces limiting the maximum wave lines. Fig. 25 displays the wave group of wavelength 5725 km (7 wavelengths in the Earth's circumference) whose frequency equals 52.4 Hz. 124 surfaces with high energy density are being formed on the Earth's surface. Their surface decreases with the increase of their frequency, and their number and energy density increases. It is interesting that the mentioned frequency is somewhat over the last Schumann resonance frequency (45 Hz)

that start from 7.8 Hz and increase approximately for 6.5 Hz. Attenuation of waves is exceptionally low in this frequency range.

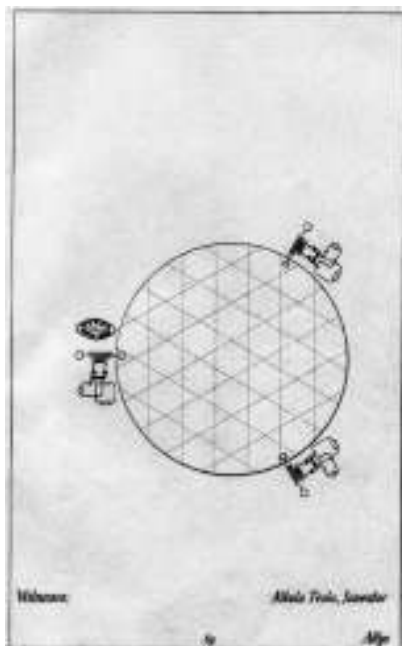

Fig. 25 – Tesla's drawing from the unpublished patent submission. Standing wave formation on the Earth's surface by means of three transmitters for wireless energy transmission. The surfaces with maximum energy density are within triangles while minimal density is within the hexagons. Courtesy of the Nikola Tesla Museum in Belgrade.

13 Tesla Transmitting Magnifier with an Independent Excitation

It can be seen from Tesla's notes during the construction of the Wardencllyffe tower how Tesla's ideas on wireless energy transmission formed and developed. In the patent submission in Fig. 16, the transmitter has one disadvantage and that entails the standing waves frequency in special coil and standing Earth frequency is the same. Namely, coils of common dimensions operate at resonance frequencies of several tens of kHz, in the frequency range in which weakening of standing waves on Earth is considerable. Tesla knew that wave weakening at low frequency propagation (up to a few kHz) is very small, but he could reach those frequencies only by using large dimension coils. This is why he devised the magnifying transmitter with independent excitation in which the high-frequency magnifying transmitter with special coil is a source for an independent oscillator emitting low frequency waves, Fig. 26. At the same time, this solution enabled also the precise determination of wavelength of

the emitted waves, because the source and the transmitter had been separated, and it reached substantial increase of the emitted power.

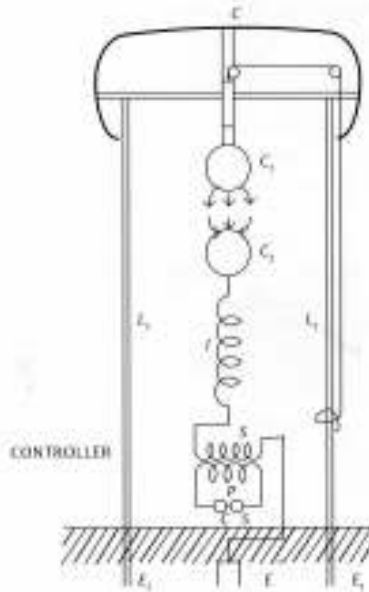

Fig. 26 – Tesla's drawing from notes, 29th May 1901 in connection with new transmitter version in Wardenclyffe. He added the spark gap C_1 - C_2 and the spark gap ball distance adjustment wire. The internal independent supply represents the high-frequency transformer with special coil (Source: Popovic Vojin, Nikola Tesla – From Colorado Springs to Long Island. Belgrade: The Nikola Tesla Museum, 2008, p.496).

On 29th May 1901, for the first and the only (noticed) time, he mentioned the new transmitter version in Wardenclyffe. He analyzed certain inductivity and capacitance in the circuit, but unfortunately did not explain the principle of its operation. Most likely, this was obvious to him as he was an experienced experiment performer, so he skipped an explanation. It can be seen that the high-frequency transformer with special coil was utilized as a generator supplying the capacitance dome C by means of the large spark gap C_1 - C_2 thereby constituting the external closed circuit with the tower body and the ground (the tower body has the inductivity L_1 , which means that it is conductive). The external independent circuit frequency can be now put in resonance with the necessary wave frequency across the Earth's surface by changing conductive elements in the tower construction. It should be noted that the structure of this tower is conductive in contrast to the original Wardenclyffe tower that was made of wood. In addition to supplying the dome, the internal high-frequency transformer with special coil does not influence the external

circuit operation, and the vice versa is applied. On the other hand, the solution is very elegant for one saves the space.

However, it remains unclear why the upper electrode of spark gaps C_1 is movable (it can be displaced by means of the wire), that is how the distance size of sphere electrodes of spark gaps influences dome voltage generation. The problem is also synchronization of internal and external circuits (high-frequency and low-frequency circuit) for dome supply, which represents a capacitor electrode ought to be performed at a precisely defined moment in order to maintain the oscillations within.

It is by this solution that Tesla implied multiple voltage increase and transmitter power. In some subsequent articles, Tesla mentioned that he had devised improvements that would enabled generating voltage over 100 MV and emitting power over 1 GW.

14 Acknowledgement

I am deeply indebted to my colleague assistant professor Milos Djuric for help in translation of text in English.

15 References

- [1] J. Cvetic: Tesla's Magnifying Transmitter Principles of Working, First International Congress "Nikola Tesla - History of the Future", 24-26 April 2015, Belgrade, Serbia.
- [2] P. Drude: About Inductive Excitation of Two Electric Resonant Circuits with Application to Measurement of Oscillation Periods and Damping, Tesla Coils and Wireless Telegraphy, *Annalen der Physik*, Vol. 318, No. 3, 1904, pp. 512 – 561. (In German).
- [3] P. Drude: Rational Construction of Tesla transformers, *Annalen der Physik*, Vol. 321, No. 1, 1905, pp. 116 – 133. (In German).
- [4] A. Oberbeck: On the Process of the Electrical Oscillations in The Tesla's Experiments, *Annalen der Physik*, Vol. 291, No. 8, 1895, pp. 623 – 632. (In German).
- [5] N. Tesla, A. Marincic, V. Popovic, M Ciric, V. Jelenkovic: From Colorado Springs to Long Island - Research Notes, The Nikola Tesla Museum, Belgrade, Serbia, 2008.