

Protecting Power Equipment Against Magnetohydrodynamic Effects (MHD) of Electromagnetic Pulses (EMP)

Vladimir Gurevich¹

Abstract: The article is devoted to the effects of geomagnetic-induced currents (GIC) on electrical equipment of power systems and analyzes technical measures for protection against such effects. It is noted that the difference between high-altitude nuclear detonation and solar storm GICs forces applying different methods of electrical equipment protection. It also illustrates that enhancement of transformer immunity to GICs without saturation prevention is not an effective measure to protect the power system. The article offers a special relay designed for fast disconnection of the transformer under GICs.

Keywords: EMP, Magnetohydrodynamic effect, Nuclear detonation, E3 component, Geomagnetic induced current, GIC.

1 Introduction

The employment of a special weapon capable of destroying power systems without any direct hazard to the people is very attractive since it can collapse the whole country and persons responsible for such employment will not be accused of the mass killing because the weapon has no direct affect on the people. These are the systems generating super high-power electromagnetic fields. The most powerful source of such fields is the electromagnetic pulse of high-altitude nuclear detonations (nuclear detonation EMP) characterized by a very complex structure. The EMP has three main components, so called E1, E2 and E3. These three components are significantly different in parameters and affect on the power systems [1]. My previous publications detailed nuclear detonation EMP damaging affect on sensitive electronic equipment, particularly on microprocessor-based relay protection. This article describes the nuclear detonation EMP affect on power equipment of transmission and distribution systems.

¹Central Electric Laboratory, Israel Electric Corp., POB 10, Haifa 31000, Israel;
E-mail: vladimir.gurevich@gmx.net

2 Magnetohydrodynamic Effect (MHD) of Nuclear Detonation EMP

The EMP magnetohydrodynamic effect (EMP MHD) is one of the nuclear detonation EMP components, referred to as E3.

It is based on MHD effects of nuclear detonation products plasma interaction with heated ionized air and the Earth's magnetic field. The MHD effect includes two stages: Blast Wave and Heave. The stages are generated differently and have different durations, see Fig. 1. The first stage with a duration from 1 to 10 seconds is based on spreading (throwing out) of large plasma products generated upon the detonation in the thin air (at high altitude) under the action of the Earth's magnetic field.

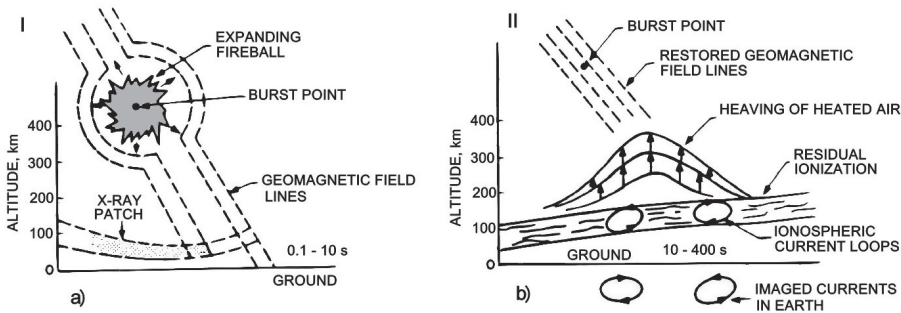

Fig. 1 – EMP MHD is consisted of two stages [2]:
a) Blast Wave; b) Heave.

Such physical effects cause significant displacement of the Earth's magnetic field increasing in proportion to the detonation power and altitude. The second stage is accompanied with heave and rapid lift of the air incandescent due to the detonation together with highly ionized air mass (that is, plasma). When ionized plasma crosses power lines of the Earth magnetic field the air layer is polarized and the powerful electric field is generated. The electric field in its turn forms high flowing currents in the ionosphere. These processes are rather slow. The duration of this detonation phase is from 10 to 300 s. This provokes complex interaction between plasma ions, magnetic field, gamma- and X-rays accompanied with generation of electric curl field.

Upon such processes in thin air, a relatively slow changing electric field (in strength from less than ten to tens of Volts per km, see Fig. 2) is generated close to the surface of the Earth.

Despite the low strength of the electric field generated with E3 of the nuclear detonation EMP, it induces rather high electric currents of low frequency (less than 1 Hz), such as quasi DC, in long metal structures (such as

pipes, rails, overhead transmission lines). The most dangerous are the currents induced in overhead transmission lines, see Fig. 3.

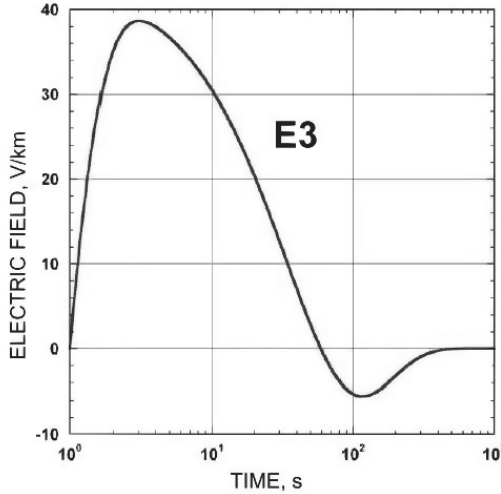

Fig. 2 – Changing horizontal component of electromagnetic field strength at the Earth's surface under the E3 component of nuclear detonation EMP [3].

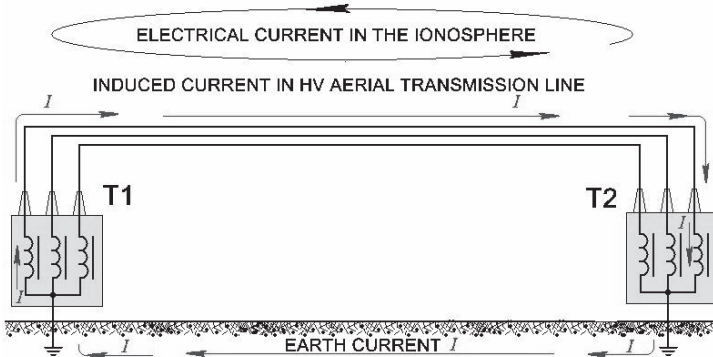

Fig. 3 – Flow chart of currents induced in electric mains and looped through the power transformer neutral conductor.

3 The Effect of E3 Component of Nuclear Detonation EMP on Power electric Equipment

Due to the very low frequency (less than 1 Hz) of the geomagnetic induced current (GIC) its effect is similar to the effect of direct current, so it will basically influence the electric equipment containing electromagnetic systems,

such as power transformers. Saturation of the power transformer yoke with quasi DC in neutral conductors causes the excitation current rise, high distortion of current curve in transformer winding, as well as a significant rise in loss on the transformer and growth of the winding and core temperature, see Fig. 4.

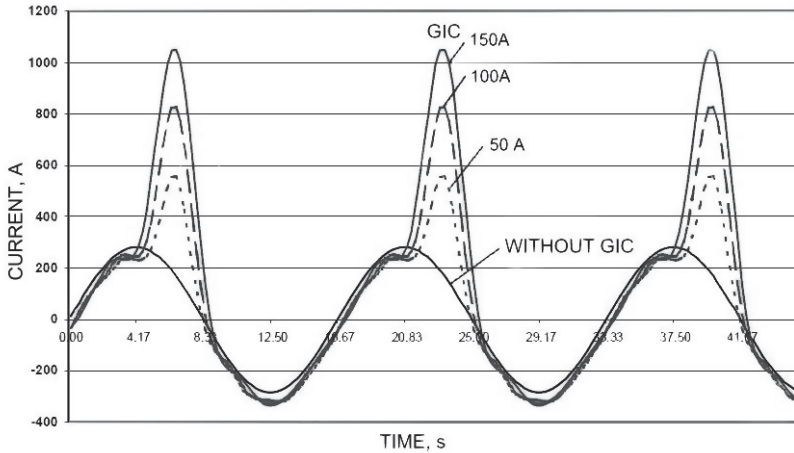

Fig. 4 – Steady-mode distortion of current shape in power transformer upon the flow of geomagnetic current of 50, 100 and 150A [4] within the transformer neutral conductor.

This mode is dangerous for the transformer since there is a high probability of making the transformer inoperative and a distortion of the entire electric power system. The steady-mode transformer is a powerful source of even and odd harmonics causing overloading of the capacitor banks of reactive power compensation systems and distorting normal operation of the relay protection. In the case of overloading the capacitor banks are disconnected by the protection devices. Combined with a simultaneous jump in steady-mode transformers consumption of reactive power (if its power is high) it causes a significant lack of reactive power in the system. Upon this, the voltage is decreased and the transformer on-load tap-changer is automatically triggered in order to restore the voltage level. Transformer on-load tap-changing device contractors are not designed for switching currents containing significant DC components and would likely be destroyed thus damaging on-load tap-changing devices and shorting the adjusting part of transformer winding. This mode should immediately trigger the circuit breakers (CB) and disconnect the damaged transformers. But are the high-voltage CB capable of disconnecting such short-circuit currents and load currents containing high DC components? The problem is that they are not designed for switching such currents. At the same time, what happens with capacitors shunting in-series poles of such a CB under the high-frequency harmonics? It is clear, that there are more questions

than answers. However, it is known that high-power solar storms generating effects similar to E3 of nuclear detonation EMP repeatedly have caused severe damage to power equipment and collapsed power systems in different countries of the world.

4 Protecting Power Equipment Against Geomagnetic Induced Currents

It is quite clear that in order to properly protect the power system equipment what is needed is the prevention of the flow of GIC through the equipment. To do this we need to prevent GIC flow through the overhead transmission lines (using capacitor banks for longitudinal capacitive compensation) or block the GIC penetration into the neutral conductor of power transformer (mounting capacitors in-series into the neutral ground circuit).

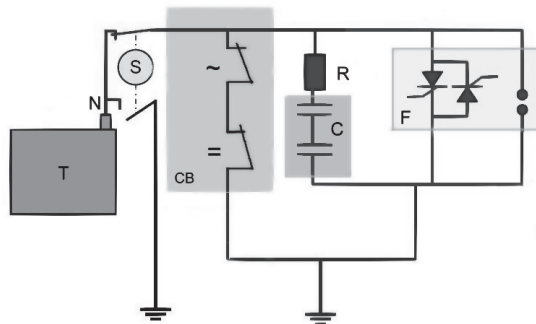

Fig. 5 – Typical design of the device blocking GIC in the neutral conductor of power transformer . *T* – transformer; *S* – switching apparatus designed for making the device inoperative; *CB* – special circuit breaker designed for disconnecting AC/DC; *C* – capacitors bank; *R* – current limiting resistor; *F* – special protection against overvoltage under emergency currents in neutral circuits.

Since a longitudinal capacitive compensation battery is very expensive, it is rarely used and only in long overhead transmission lines for balancing the line's inductive reactance. Lately, capacitor-based units preventing GIC penetration into the power transformer neutral conductor have been intensively developed.

However there is a problem: if GIC is absent, such unit doesn't have to affect normal operation of transformers and mains, that is, it should not reduce effectiveness of neutral conductor PE while it must withstand the flow of high short-circuit currents and generate ferroresonance and overvoltage in transition modes. For this reason, the operation algorithm of all types of such units ensures constant shunting of the capacitor bank with bypass power CB and the capacitor bank is made operable upon the de-shunting (opening this CB) only at the moment of GIC discovery, see Fig. 5.

The appearance of the emergency mode in the circuit with capacitors integrated in the neutral line can cause the appearance of very high voltages (above neutral line isolation level) in the neutral circuit of the transformer and at the capacitors. Thus, such units should be equipped with special devices protecting against overvoltage F (regular power varistors are not suitable due to their limited power dissipation for relative prolonged short circuit current). Fig. 5 illustrates a conventional protection device containing a set of 6 powerful high-voltage thyristors and vacuum arrester, In practice, powerful controlled three-electrode arresters of special design (see Fig. 6) are also used instead of the thyristor set.

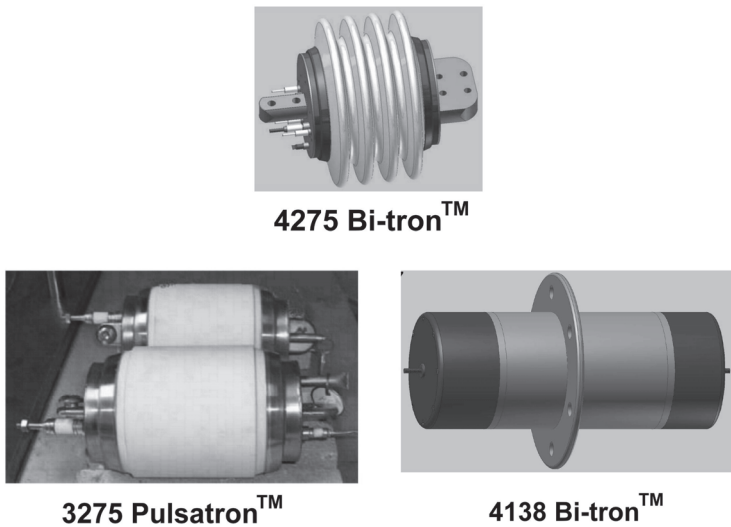

Fig. 6 – High-power high-voltage controlled arresters by Advanced Fusion Systems types 4275 (35 kV, 100 kA); 3275 (500 kV, 250 kA); 4138 (75 kV, 250 kA).

Besides, the disconnection of this unit with special isolating switch-over apparatus (S) equipped with a discharge grounding switch designed for making the device inoperable (for technical maintenance) without transformer disconnection should be ensured. It is clear, that such unit is both complex and expensive (more than 300K USD), see Fig. 7.

There are other methods of protecting power transformers against GIC requiring the modification of transformer design. Additional nonmagnetic gaps installed in the transformer core reduce the probability of its saturation but affect the basic technical indices of the transformer. Other known technical solution (see Fig. 8) include the installation in the transformer core of additional winding balancing the DC effects and shunted with the special element (31) characterized by high DC resistance and low AC resistance.



Fig. 7 – GIC blocking unit integrated into the power transformer neutral conductor. Above is the unit manufactured by ABB Company equipped with controller manufactured by SEL, below is the unit designed by Phoenix Electric

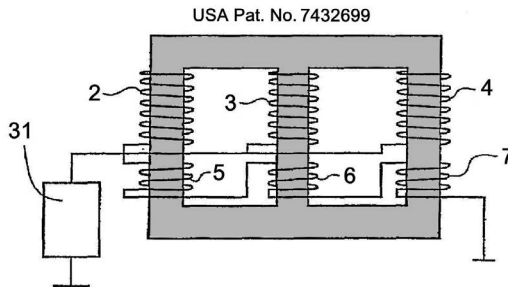

Fig. 8 – Power transformer with additional winding balancing GIC. 2-4 – basic winding; 5-7 – compensation winding; 31 – element with high DC resistance and low AC resistance.

Apparently, this “special element” can be the capacitor bank while it is not clearly stated in USA Patent 7432699. USA Patent 7489485 describes the same technical solution. There are other technical solutions suggesting connecting this compensation winding to the external controlled DC source balancing GIC. Some other patents suggest connecting the transformer windings according to the Inverse Zig-Zag method allowing for cancellation of equal but opposite excitation currents at each phase, so the core is not saturated.

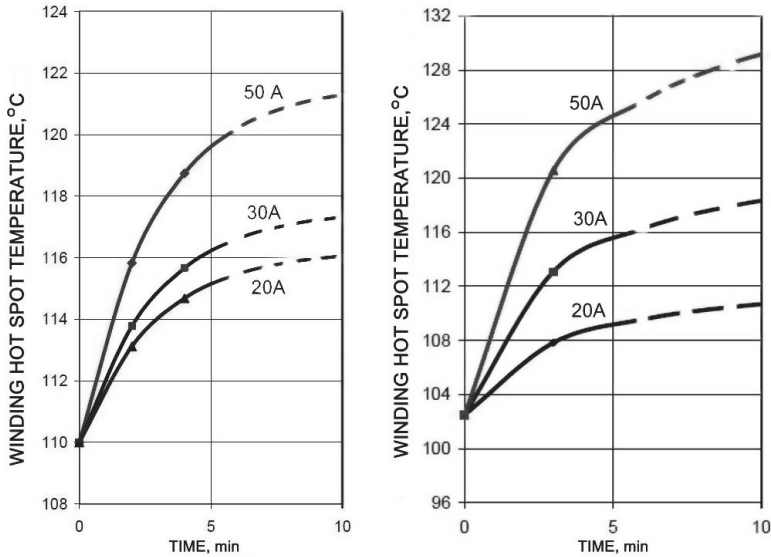

Fig. 9 – Example of power transformer winding (left) and yoke (right) heating under the geomagnetic currents of 20, 30 and 50 A flowing in the neutral.

All such technical solutions require modifying the power transformer manufacturing processes, deteriorating the technical parameters and leading to the significant rise in price. So, any technical measures aimed to prevent/cancel GIC currents lead to the significant material costs. Accordingly, there is a question if it is reasonable to invest significant means into electric equipment damage control upon such exceptional emergencies as high altitude nuclear detonation.

Some world leading manufacturers of high-voltage transformers (such as Siemens, ABB, etc.) have announced the development of special transformers (“GIC Safe Power Transformers”) capable of withstanding GIC of up to 50 A within several hours and individual GIC pulses with amplitudes up to 200 A within several hours. Promotion materials do not contain any technical solutions enhancing the transformers immunity to GIC. However, it is clear that such solutions do not include measures blocking the penetration of quasi DC current into the transformer neutral conductor, or balancing magnetic flows in the core since such solutions do not limit GIC exposure time as well as they do not strictly limit the GIC value. Probably, such transformers sustain high temperatures due to isolation of plates with special high temperature lacquers and winding isolation materials.

Improvement of the transformer immunity to the quasi DC currents flowing through is not the complete solution since, as mentioned above, the transformer

with saturated core can significantly affect many other types of power equipment. This means that maintaining transformer operability doesn't ensure operability of the power system.

A high investment into the protection of power system against individual and unlikely events is hardly reasonable. So, why is such protection kind developed and offered to the market? The point is that GIC generated upon the high-altitude nuclear detonations is also generated during the high-power solar storms repeatedly causing severe power system collapses. However, the danger of solar storms depends on the region. The most dangerous are the poles of the Earth and the least dangerous is the equator. Regions long-distanced from the poles are not exposed to significant GIC capable of affecting power system operability. Nevertheless, the developers of protection usually mention that solar storm and high-altitude nuclear detonation GICs are very similar and recommend installing such devices in order to improve the power system immunity to high-altitude nuclear detonations despite the region. It sounds quite true. But there is one significant difference between GICs challenging this logic. It is GIC length. Upon high-altitude nuclear detonation the GIC lasts only a few minutes. Within this period power transformers of high heat-sink capacity do not have enough time to heat up to the dangerous temperature, see Fig. 9.

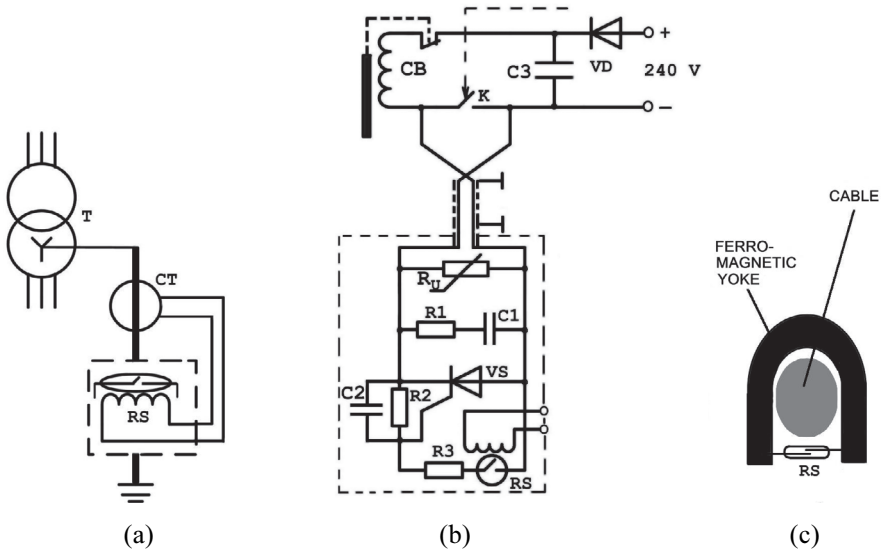

Fig. 10 – Power transformer protection relay protecting against low-frequency geomagnetic currents induced into the neutral circuit.

It is clear that under the high GIC the temperature of transformer parts will be high but not dangerous due to the very short exposure time. Currents distorted with asymmetrically saturated transformer are much more dangerous

for other types of power equipment (see above) less inert than power transformers. Solar storm GICs may last for many hours and during that period power supply should be ensured. High altitude detonation GICs last several minutes and during that period the power equipment can be disconnected to prevent the damage, and put into operation again. Since GIC builds-up slow the transformers can be disconnected immediately after the discovery of the DC component in the neutral current before the core is saturated and following processes occur. Such protection of power system equipment against nuclear detonation EMP MHD looks more reasonable compared to that discussed above since it is both highly effective and less expensive. All charges for the implementation of such protection relate to the installation of a special relay reacting to the appearance of the DC component in the neutral current and immediately triggering the transformer disconnection.

Such a relay must have a special design different from the one used by ABB for controlling SolidGround™ device (industrial PLK of SEL-2240 type), since such a device provides protection against E_3 of nuclear detonation EMP MHD which appears after E_1 and E_2 and is likely to be capable of damaging microprocessor control device SEL-2240 before it is triggered.

Fig. 4a shows the operational principle of the relay sensitive to the DC component in the power transformer neutral and insensitive to the widely varying AC component.

The relay consists of a reed switch, RS, with a coil placed on the cable (bus) that connects the transformer neutral to the grounding point perpendicular to the axis of the cable, and a conventional toroidal current transformer, CT, installed on the same cable.

If there is no DC current in the neutral the magnetic field of the cable (bus) acting directly on the reed switch, this is fully compensated by the magnetic field of the coil put on the reed switch and powered by the current transformer. AC current changes in the neutral lead proportionally to the changes in both magnetic fields acting on the reed switch, and to their compensation. Under high DC currents in the neutral (over 10 – 20 A), the balance of the magnetic fields acting on the reed switch is offset: the magnetic field of the cable (bus) still acts while the compensating magnetic field of the coil energized by the current transformer is disabled as the DC component of the current is not transformed by the current transformer. This leads to reed switch activation. The real relay circuit includes an additional output amplifier installed on VS thyristor, varistor R_U and the R_1C_1 all protecting the thyristor from interferences and voltage surges, see Fig. 4b. The relay is equipped with a continuous electrostatic shield and a ferromagnetic shield with the only window on the cable side next to the reed switch and is connected to the circuit of the CB switch trip coil through a special twisted-pair control cable with the combined

multi-layer shielding grounded at both ends [3] and resistant to the electromagnetic pulses [2]. The relay can be constructed on miniature high-voltage vacuum reed switches, for example, of type KSK-1A85 (manufactured by Meder Electronics), with the electric strength of insulation between the contacts of 4000 V and the bulb having a diameter of 2.75 mm and length of 21 mm. This reed switch is capable of switching loads up to 100 W (the maximum switching voltage is 1000 V, the maximum switching current is 1 A) with the response time of 1 ms and a maximum sensitivity of 20 A. Additional ferromagnetic elements (magnetic field concentrators) located next to the reed switch can be used to increase the sensitivity. To get a relay with lower sensitivity and a higher pickup, the longitudinal axis of the reed switch should form a non-perpendicular angle to the axis of the cable on which it is installed.

The thyristor should also be miniature and of high-voltage, e.g., of type SKT50/18E (manufactured by Semicron), with a maximum voltage of 1800 V and maximum continuous current of 75 A, and must withstand high rates of voltage rise (1000 V/ μ s) under a wide operating temperature range ($-40\dots+130$ °C). The power circuit of the trip coil is equipped with storage capacitor C_3 enabling switch activation even under the loss of operating voltage. The R_2C_2 in series is designed to further enhance the immunity of the device. Capacitor C_2 provides a certain delay of the thyristor switch-on, preventing it from unlocking under the powerful impulse noise.

Application of the discrete high-voltage components instead of conventional microelectronics in the relay ensures its high reliability under powerful electromagnetic interferences and surge voltages specific to solar storms and electromagnetic pulses.

The purpose of this article was to identify the problem and present a simple solution. For this end we have described a relay design to demonstrate its general concept only. It is obvious that the described device can be supplemented by signal relay (blinker) registering the response, time delay device, reed switch sensitivity control unit, reinforced insulation [6], etc. We believe that the proposed solution is more than adequate and far cheaper to implement than other proposed solutions.

5 Conclusion

1. Nuclear detonation EMP MHD results in quasi DC current flowing through the power transformer neutral conductors and affects both transformers and many other types of power equipment (particularly, capacitor banks and high-voltage circuit breakers). Thus, technical arrangements aimed to protect the systems against nuclear detonation EMP MHD should protect both transformers and other types of power system equipment. Technical arrangements aimed to improve the

transformer immunity to the flows of such currents without blocking or canceling GIC are not deemed as effective.

2. Available solutions preventing transformer core saturation can be subdivided as follows:
 - External units installed at the transformer neutral breaks and blocking the flow of quasi DC current in the neutral circuit
 - Internal modification of the transformer (windings or core) preventing the saturation of the core during the flow of quasi DC current in the neutral circuit

All known solutions aimed to maintain proper operation of power systems exposed to GIC are costly.

3. Despite of the similarity of parameters of different GICs (nuclear detonation E3 and solar storm) there is one significant difference: it is GIC length. This difference dictates the employment of different methods of electric equipment protection against solar storms and E3 of nuclear detonation EMP MHD.
4. Known technical solutions providing protection of power system equipment against nuclear detonation EMP MHD can not be deemed as economically sound. In this case, I suggest it is more reasonable to briefly disconnect the power transformer (for several minutes) triggered by special protection relay, and then put it into operation again automatically.
5. GIC protection relay should have a special design ensuring its operation under the all components of nuclear detonation EMP.

6 References

- [1] V. Gurevich: *Cyber and Electromagnetic Threats in Modern Relay Protection*, CRC Press, NY, USA, 2015.
- [2] J.R. Legro, N.C. Abi-Samra, F.M. Tesche: *Study to Access the Effects of Magnetohydrodynamic Electromagnetic Pulse on Electric Power Systems*. – Report ORNL/sub-83/43374/1/v3, Oak Ridge National Laboratory, Oak Ridge, TN, USA, May 1985.
- [3] IEC 61000-2-9 *Electromagnetic Compatibility (EMC) – Part 2: Environment – Section 9: Description of HEMP Environment – Radiated Disturbance*, Geneva, Switzerland, Feb. 1996.
- [4] J. Gilbert, J. Kappenman, W. Radasky, E. Savage: *The Late-Time (E3) High-Altitude Electromagnetic Pulse (HEMP) and Its Impact on the U.S. Power Grid*, Report Meta-R-321, Metatech Corporation, Goleta, CA, USA, Jan. 2010.
- [5] V. Gurevich: *Protection Devices and Systems for High-Voltage Applications*, Marcel Dekker, NY, USA, 2003.