

# Sliding Mode Controller for Four Leg Shunt Active Power Filter to Eliminating Zero Sequence Current, Compensating Harmonics and Reactive Power with Fixed Switching Frequency

Ali Chebabhi<sup>1</sup>, Mohammed-Karim Fellah<sup>1</sup>,  
Mohamed-Fouad Benkhoris<sup>2</sup>, Abdelhalim Kessal<sup>3</sup>

**Abstract:** In this paper, the four leg inverter controlled by the three dimensional space vector modulation (3D SVM) is used as the shunt active power filter (SAPF) for compensating the three phase four wire electrical network, by using the four leg inverter with 3D SVM advantages to eliminated zero sequence current, fixed switching frequency of inverter switches, and reduced switching losses. This four leg inverter is employed as shunt active power filter to minimizing harmonic currents, reducing magnitude of neutral wire current, eliminating zero sequence current caused by nonlinear single phase loads and compensating reactive power, and a nonlinear sliding mode control technique (SMC) is proposed for harmonic currents and DC bus voltage control to improve the performances of the three phase four wire four leg shunt active power filter based on Synchronous Reference Frame (SRF) theory in the dq0 axes, and to decoupling the four leg SAPF mathematical model.

**Keywords:** Shunt active power filter, Space vector modulation, Sliding mode control, Synchronous reference frame.

## 1 Introduction

The increasing development of the industry has led research in the field of semiconductors and in particular power electronics. The results of these researches are very important in the industrial and improved significantly the process performances, which explains the high use of static converters in the industry, these great benefits are not without disadvantages, the main disadvantage is the static converters are nonlinear loads absorb reactive power and non sinusoidal current, which is very bad for the network, as a degradation of the current and voltage waveform quality [1 – 3]. Today, many active

---

<sup>1</sup>ICEPS Laboratory (Intelligent Control & Electrical Power Systems), Djillali Liabes University of Sidi Bel Abbes, Algeria; E-mails: chebabhiali@gmail.com; mkfellah@yahoo.fr

<sup>2</sup>IREENA Laboratory (Institut de Recherche en Energie Electrique de Nantes Atlantique), University of Nantes at Saint Nazaire, France; E-mail: Mohamed-Fouad.Benkhoris@univ-nantes.fr

<sup>3</sup>Faculty of Technology, University of Bordj Bou Arreridj, Algeria; E-mail:abdelhalim.kessal@yahoo.fr

compensators, or also called active filters are proposed and studied, they differ in how they connect to the network (series or shunt), by their functionality (current or voltage compensating) and the electrical structure of the power circuit (voltage or current inverter) [3 – 5]. These active filters have, as main objective, to inject harmonic currents or voltages in the electrical network, equal to that absorbed by the non-linear load and in phase opposite, consequently it improves the power quality and power factor [6 – 8].

The three leg shunt active power filters for three phase three wire and four wire distribution systems have already been presented [9 – 10]. These three leg shunt active power filters can compensate the harmonic current generated by nonlinear three phase loads; however they are not preferable to compensate the harmonic current due to nonlinear single phase loads connected to the four wire distribution systems and the amplitude of the zero sequence current is not reduced. To remedy these problems it will be necessary to provide a four leg shunt active power filter [11–14].

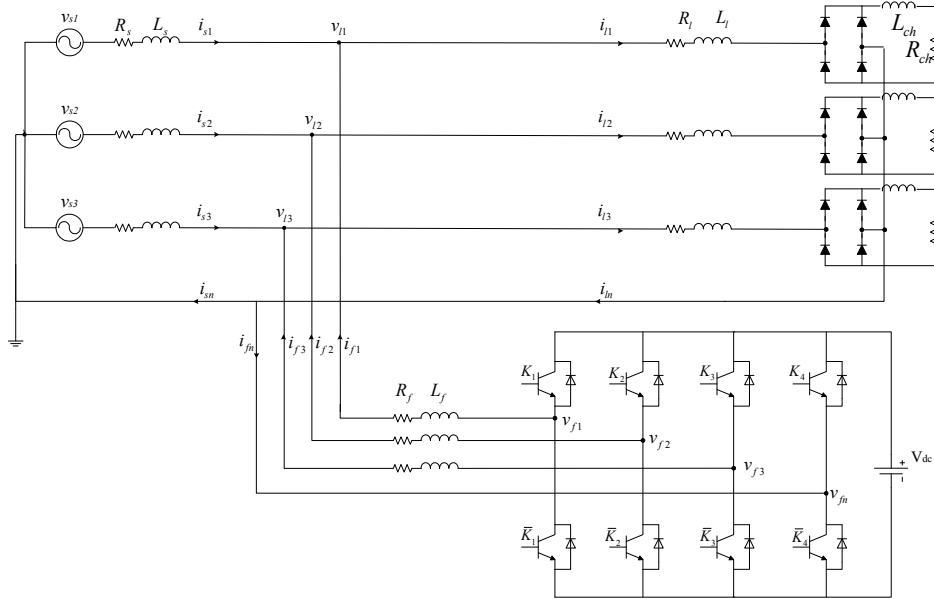
The four leg shunt active power filter topology, Fig.1, can reduce zero sequence current and the harmonic currents caused by nonlinear single phase loads in three phase four wire electrical network. This topology based on four leg inverter, which is the most common one because of its good efficiency. Its performance depends on the adoptive control approaches, for this, there are four major parts of an active power filter controller. The first is the reference signal generate techniques, the second is the switching signals generate techniques, the third is the harmonic currents and DC bus voltage control, and the fourth is the four leg inverter.

In this paper, the synchronous reference frame theory in the dq0 axes for the reference signals generate is applying, and we use the 3D SVM technique for generating the switching signals, [13 – 19], and also the nonlinear sliding mode control (SMC) is used to harmonic currents and DC bus voltage of four leg SAPF controller, because the advantages of robustness and stability under unbalanced or large loads variations, decoupling the nonlinearity of these four leg SAPF mathematical model, eliminated the DC bus voltage overshoot, minimizing the harmonic currents, simple to obtain, and has been widely applied to electrical power systems and electrical machine drives [20 – 27].

## **2 Structure and Modeling of the Three Phase Four Wire Four Leg SAPF**

The three phases four wire four leg shunt active power filter topology presented in this paper is shown in Fig. 1 [3, 12 – 13]. The main circuit contains a three phase power source with three series impedance  $L_S - R_S$  and a three single phase nonlinear loads composed of three filters characterized as  $L_l - R_l$  with three single phase rectifier supplying a three  $R_{ch} - L_{ch}$  loads, this

SAPF is shunt connected to a three phase four wire electrical network in a point called the Point of Common Coupling (PCC) on the loads side through a filter featured as  $L_f - R_f$ . This is necessary for eliminating current ripples due to switching [3].



**Fig. 1** – Four leg shunt active power filter connected in Parallel to a three phase four wire electrical network.

The four leg inverter is composed by four legs, each leg of the inverter is composed of two switches, and each switch is constituted by a transistor with anti-parallel diode, and DC side capacitor is used to store the necessary reactive energy Fig. 1.

The neutral current  $i_{sn}$  and zero sequence current  $i_o$  are given by

$$i_o = \frac{1}{\sqrt{3}} i_{sn} = \frac{1}{\sqrt{3}} (i_{s1} + i_{s2} + i_{s3}), \quad (1)$$

where  $i_{s1}, i_{s2}, i_{s3}$  are source currents.

Equation (2) expresses the inverter output voltages. These output voltages are expressed as a function of the voltage ( $V_{dc}$ ), and of the switching functions  $S_{ij}$  [12, 15, 18]

$$\begin{cases} v_{f1} = (S_1 - S_n)V_{dc} \\ v_{f2} = (S_2 - S_n)V_{dc} \\ v_{f3} = (S_3 - S_n)V_{dc} \end{cases}, \quad (2)$$

where  $v_{fi}$  are phase-to-neutral voltages ( $i = 1, 2, 3, n$ ),  $S_i$  is switching state and  $V_{dc}$  is DC bus voltage.

The input current  $i_d$  of the four leg inverter is calculated as (3).

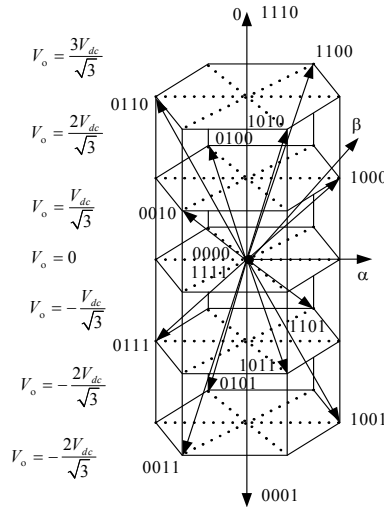
$$i_d = S_1 i_{f1} + S_2 i_{f2} + S_3 i_{f3} - S_n i_{fn} \quad (3)$$

The vector tension of the four leg inverter is represented by:

$$\vec{v}_f = v_{f\alpha} \vec{i} + v_{f\beta} \vec{j} + v_{f0} \vec{k}, \quad (4)$$

where  $v_{f\alpha}, v_{f\beta}, v_{f0}$  are the projections of vector  $\vec{v}_f$  in the  $\alpha\beta 0$  axes. That gives [15]:

$$\begin{bmatrix} v_{f\alpha} \\ v_{f\beta} \\ v_{f0} \end{bmatrix} = \sqrt{\frac{2}{3}} v_{dc} \begin{bmatrix} 1 & \frac{1}{2} & \frac{1}{2} \\ 0 & \frac{\sqrt{3}}{2} & -\frac{\sqrt{3}}{2} \\ \frac{1}{\sqrt{2}} & \frac{1}{\sqrt{2}} & \frac{1}{\sqrt{2}} \end{bmatrix} \begin{bmatrix} v_{f1} \\ v_{f2} \\ v_{f3} \end{bmatrix}. \quad (5)$$



**Fig. 2** – Space vector diagram showing switching states of four leg inverter.

The space vector diagram of a four leg inverter is showed in Fig. 2. They are 16 possible switching vectors: fourteen active vectors and two null vectors of four leg inverter.

The four leg SAPF mathematical model in the dq0 axes is given by [13].

$$\begin{aligned}
 \frac{di_{fd}}{dt} &= -\frac{R_f}{L_f}i_{fd} + \omega i_{fq} + \frac{1}{L_f}v_{fd} - \frac{1}{L_f}v_{ld}, \\
 \frac{di_{fq}}{dt} &= -\frac{R_f}{L_f}i_{fq} - \omega i_{fd} + \frac{1}{L_f}v_{fq} - \frac{1}{L_f}v_{lq}, \\
 \frac{di_{f0}}{dt} &= -\frac{R_f}{L_f}i_{f0} + \frac{1}{L_f}v_{f0} - \frac{1}{L_f}v_{l0}, \\
 \frac{dV_{dc}}{dt} &= \frac{1}{C}i_{dc}^*.
 \end{aligned} \tag{6}$$

### 3 The Three Dimensional Space Vector Modulation (3D SVM)

In three dimensional space vector modulation (3D SVM), there are 16 possible switching vectors: fourteen active non zero vectors and two null vectors [7 – 8].

Six prisms in the 3D space vector diagram can be identified and numbered as Prisms I through VI, each of these six prisms is decomposed into four tetrahedrons are labeled T<sub>1</sub>–T<sub>4</sub>. Within the selected prism, there are six non zero switching state vectors and two zero switching state vectors [13]. This method is represented and studied in detail as [15 – 19].

### 4 Sliding Mode Control

The three phase load currents,  $i_{l1}$ ,  $i_{l2}$ ,  $i_{l3}$ , based on Clark transformation, are used to obtain synchronous reference frame load currents,  $i_{ld}$ ,  $i_{lq}$ ,  $i_{l0}$ , according to the following equation.

$$\begin{bmatrix} i_{ld} \\ i_{lq} \\ i_{l0} \end{bmatrix} = \sqrt{\frac{2}{3}} \begin{bmatrix} \cos(\theta) & \sin\left(\theta - \frac{2\pi}{3}\right) & \cos\left(\theta + \frac{2\pi}{3}\right) \\ -\sin(\theta) & -\sin\left(\theta - \frac{2\pi}{3}\right) & -\sin\left(\theta + \frac{2\pi}{3}\right) \\ \frac{1}{\sqrt{2}} & \frac{1}{\sqrt{2}} & \frac{1}{\sqrt{2}} \end{bmatrix} \begin{bmatrix} i_{l1} \\ i_{l2} \\ i_{l3} \end{bmatrix}. \tag{7}$$

Based on the SRF theory [28, 29], the currents  $i_{ld}$  and  $i_{lq}$  can be expressed as the sum of two components, one direct and the other is alternative, such as:

$$\begin{bmatrix} i_{ld} \\ i_{lq} \end{bmatrix} = \begin{bmatrix} \bar{i}_{ld} + \tilde{i}_{ld} \\ \bar{i}_{lq} + \tilde{i}_{lq} \end{bmatrix} \tag{8}$$

with  $\bar{i}_{id}$  and  $\bar{i}_{iq}$  are the direct components, the  $\tilde{i}_{id}$  and  $\tilde{i}_{iq}$  are alternative components of  $i_{id}$  and  $i_{iq}$  respectively.

To obtain the direct and alternative current components of the reference state variable vector  $x^*$ , the  $i_{id}$  current is extracted based on the SRF theory [28, 29] by the low pass filter (LPF) to calculate the reference component  $i_{fd}^*$  (alternative components). The  $i_{iq}$  and zero sequence currents  $i_{f0}$  are used as reference components  $i_{fq}^*$  and  $i_{f0}^*$  [14, 22].

The model (6) is a multi-input multi-output nonlinear system [21 – 24], in the three phase four wire four leg shunt active filter with sliding mode control, the outputs filter  $i_{fd}, i_{fq}, i_{f0}$  and  $V_{dc}$  are the  $d$ -axis,  $q$ -axis and the zero sequence axis SAPF currents and the DC bus voltage respectively, the control variables  $v_{fd}^*, v_{fq}^*, v_{f0}^*$  are the reference voltages. This model can be written into the following state space general form: [14, 22]

$$\dot{X} = AX + Bu + D, \quad (9)$$

where:

$$X = \begin{bmatrix} x_1 \\ x_2 \\ x_3 \end{bmatrix} = \begin{bmatrix} i_{fd} \\ i_{fq} \\ i_{f0} \end{bmatrix}, \quad \dot{X} = \begin{bmatrix} \dot{x}_1 \\ \dot{x}_2 \\ \dot{x}_3 \end{bmatrix} = \frac{d}{dt} \begin{bmatrix} i_{fd} \\ i_{fq} \\ i_{f0} \end{bmatrix}, \quad u = \begin{bmatrix} u_d \\ u_q \\ u_o \end{bmatrix} = \begin{bmatrix} v_{fd}^* \\ v_{fq}^* \\ v_{f0}^* \end{bmatrix},$$

$$A = \begin{bmatrix} -\frac{R_f}{L_f} & -\omega \\ -\omega & -\frac{R_f}{L_f} \end{bmatrix}, \quad B = \begin{bmatrix} 1 \\ L_f \end{bmatrix}, \quad D = \begin{bmatrix} -\frac{1}{L_f}v_{fd} \\ -\frac{1}{L_f}v_{fq} \\ -\frac{1}{L_f}v_{f0} \end{bmatrix},$$

$$K = \begin{bmatrix} k_d & 0 & 0 \\ 0 & k_q & 0 \\ 0 & 0 & k_0 \end{bmatrix}, \quad K_i = \begin{bmatrix} k_{id} & 0 & 0 \\ 0 & k_{iq} & 0 \\ 0 & 0 & k_{i0} \end{bmatrix}.$$

Equation (10) represents the three sliding surface of the filter currents  $i_{fd}$ ,  $i_{fq}$  and  $i_{f0}$ :

$$S(X) = K(X^* - X) + K_i \int (X^* - X) dt, \quad (10)$$

where:

$$X^* = \begin{bmatrix} x_1^* \\ x_2^* \\ x_3^* \end{bmatrix} = \begin{bmatrix} i_{fd}^* \\ i_{fq}^* \\ i_{f0}^* \end{bmatrix} = \begin{bmatrix} \tilde{i}_{ld} - i_{dc} \\ i_{lq} \\ i_{l0} \end{bmatrix}. \quad (11)$$

The current  $i_{dc}$  at the output of DC bus voltage controller used to compensated the losses power of four leg inverters and to conserved the necessary reactive energy stored in the DC side capacitor is calculated as follow [11]:

$$u_v = i_{dc} = c_1 x_4 y_1 + c_2 x_5 y_2, \quad (12)$$

where  $y_1$  and  $y_2$  are switching functions

$$x_4 = e(V_{dc}) = V_{dc}^* - V_{dc}, \quad x_5 = \dot{x}_3, \quad x_6 = \int x_4 dt, \quad (13)$$

$$y_1 = \begin{cases} 1, & x_4 S(x_4) > 0 \\ -1, & x_4 S(x_4) < 0 \end{cases}, \quad (13)$$

$$y_2 = \begin{cases} 1, & x_5 S(x_4) > 0 \\ -1, & x_5 S(x_4) < 0 \end{cases}. \quad (14)$$

The sliding surface  $S(x_4)$  of the DC bus voltage is given by (15) [23]

$$S(x_4) = S(V_{dc}^* - V_{dc}) = c_k x_4 + x_5 + c_i x_6, \quad (15)$$

$$S(x_4) = c_k e(V_{dc}) + \frac{d}{dt} e(V_{dc}) + c_i \int e(V_{dc}) dt$$

and  $c_k, c_i$  are positive constants.

The three sliding surface of the three filter currents  $i_{fd}, i_{fq}, i_{f0}$  are

$$S(i_{fd}) = k_d (i_{fd}^* - i_{fd}) + k_{id} \int (i_{fd}^* - i_{fd}) dt, \quad (16)$$

$$S(i_{fq}) = k_q (i_{fq}^* - i_{fq}) + k_{iq} \int (i_{fq}^* - i_{fq}) dt,$$

$$S(i_{f0}) = k_0 (i_{f0}^* - i_{f0}) + k_{i0} \int (i_{f0}^* - i_{f0}) dt.$$

During the sliding mode, we have

$$S(i_{fd}) = S(i_{fq}) = S(i_{f0}) = 0, \quad (17)$$

$$\dot{S}(i_{fd}) = \dot{S}(i_{fq}) = \dot{S}(i_{f0}) = 0.$$

The control variables are given by:

$$u = \begin{bmatrix} v_{fd}^* \\ v_{fq}^* \\ v_{f0}^* \end{bmatrix} = u_{dis} + u_{eq}. \quad (18)$$

Solving (9) gives the expression of the equivalent command as follows:

$$u_{eq} = (KB)^{-1} \left[ K_i (\dot{X}^* - X) - K (\dot{X}^* - AX - D) \right] = \begin{bmatrix} u_{eqd} \\ u_{eqq} \\ u_{eq0} \end{bmatrix}. \quad (19)$$

If the trajectories are different from the state of the sliding surface, the discontinuous control ensures decrease the distance between the state trajectory and the sliding surface [22, 26]. This command is selected to ensure the convergence of the path to its reference [14]. In our case, we chose the discontinuous control function as:

$$u_{dis} = \begin{bmatrix} u_{disd} \\ u_{disq} \\ u_{dis0} \end{bmatrix} = \text{sgn}(S(X)) U_{\max}, \quad U_{\max} = \begin{bmatrix} U_{d \max} \\ U_{q \max} \\ U_{0 \max} \end{bmatrix} \quad (20)$$

## 5 Simulation Results

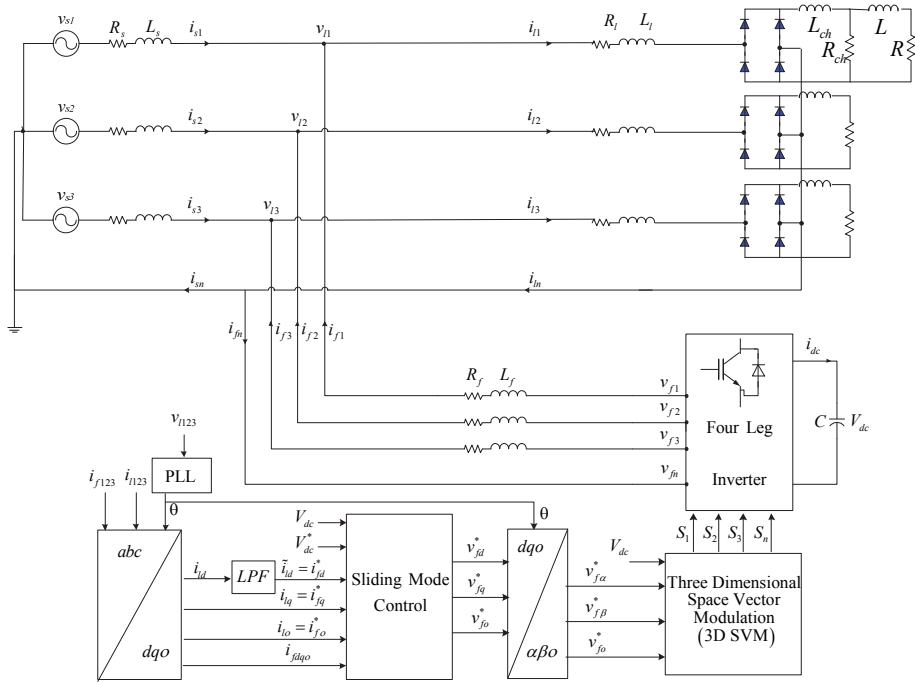
The SimPower Systems and S-Function of MATLAB are used for implemented the three phase four wire four leg shunt active power filter controlled by nonlinear sliding mode technique Fig. 3.

The components, parameters, and conditions considered for simulation are listed in **Table 1** and **2**.

**Table 1**  
*System parameters for simulation and load specifications.*

Capacitance of the capacitor	5 mF
Coupling impedance $R_f, L_f$	0.2 mΩ, 0.15 mH
The source voltage and frequency	220 V, 50Hz
Source impedance $R_s, L_s$	1 mΩ, 1 mH
Line impedance $R_{ch}, L_{ch}$	1 mΩ, 1 mH
Load impedance $R_l, L_l$	5Ω, 10 mH



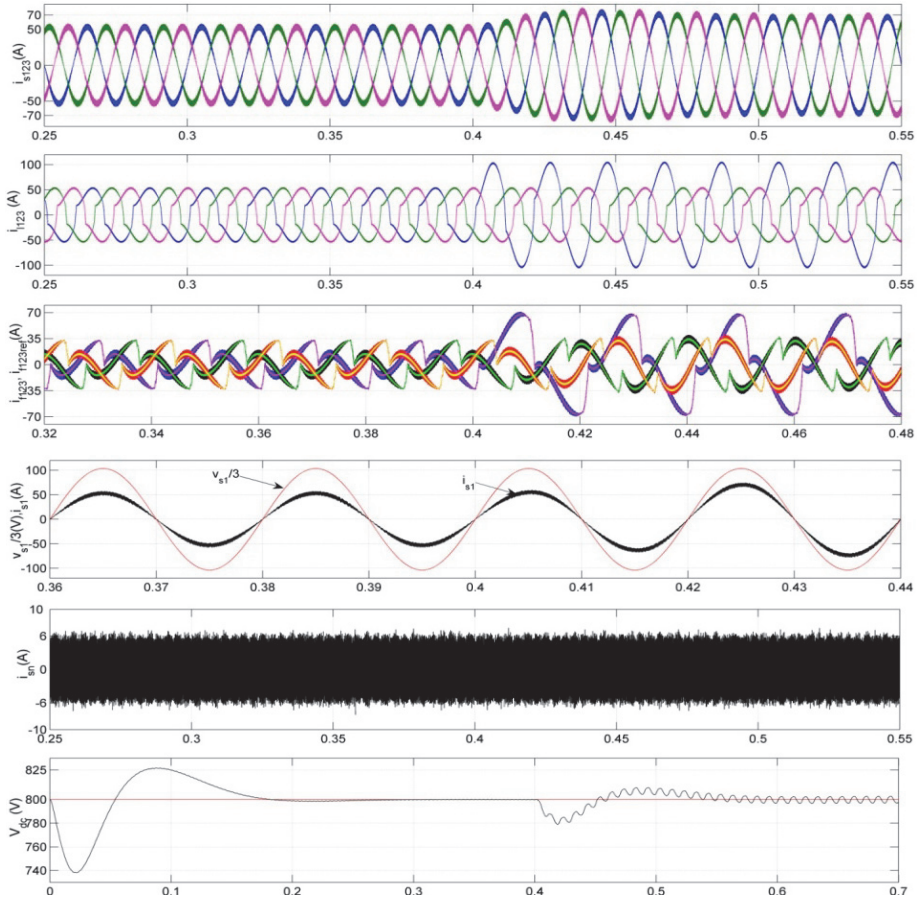


**Fig. 3** – Schematic block diagram of shunt active power filter with Sliding Mode control technique.

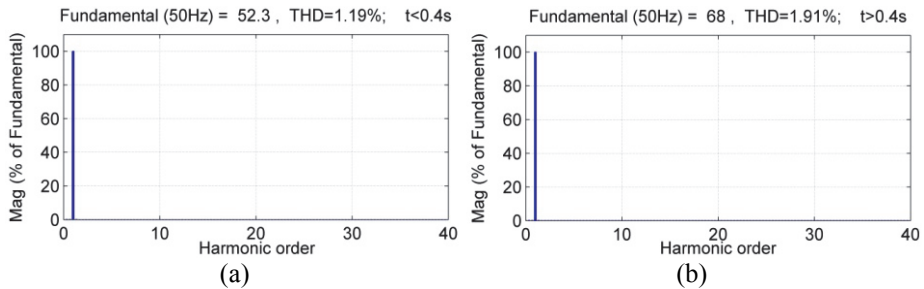
**Table 2**  
The conditions considered for simulation.

	PI	Sliding Mode
The switching frequency: $f_s$	14 kHz	14 kHz
The reference voltage: $V_{dcref}$	800 V	800 V
The currents regulators frequency: $f_c$ $k, k_i, u_{max} = \text{constant}$	10 kHz	$k_{id} = k_{iq} = k_{i0} = 5.5e^5$ $k_d = k_q = k_0 = 2e^{-8}$ $u_{dmax} = u_{qmax} = u_{0max} = 800$
The voltage regulator frequency: $f_{ds}$ $c_k, c_i, c_1, c_2 = \text{constant.}$	4 Hz	$c_k = c_i = 950$ $c_1 = 0.43$ $c_2 = 5e^{-6}$

### 5.1 Simulation with PI control

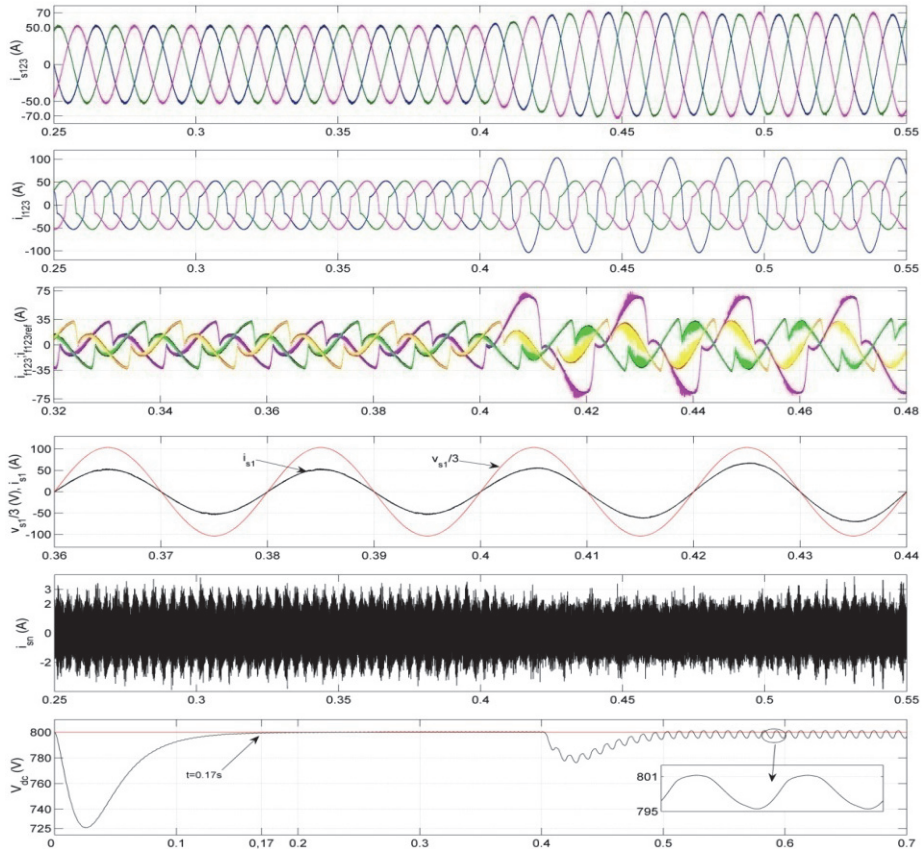


**Fig. 4** – Performance of the three phases four wire four leg SAPF using Synchronous Reference Frame theory (SRF) based 3D SVM control strategy using PI control in the dq0 axes.

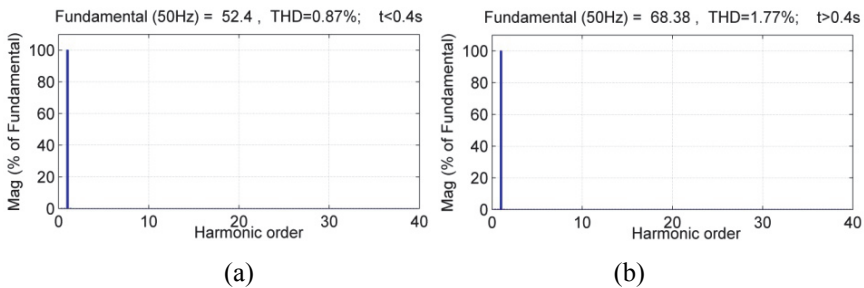


**Fig. 5** – Magnitude Spectrum of Source Currents for the PI control: (a) before unbalanced load, (b) after unbalanced Load.

## 5.2 Simulation with Sliding Mode Control



**Fig. 6** – Performance of the three phase four wire four leg SAPF using Synchronous Reference Frame theory (SRF) based 3D SVM control strategy using SMC in the dq0 axes.



**Fig. 7** – Magnitude Spectrum of Source Currents for the SMC: (a) before unbalanced load, (b) after unbalanced Load.

Fig. 4 and 6 illustrates the three phase four wire four leg SAPF performance with the two controller (PI and SMC) under unbalanced loads, the source currents waveform is sinusoidal and in phase with the corresponding voltage (the power factor is unitary). The amplitude of the neutral wire current is in the range of  $\pm 6A$  with PI controller and the range of  $\pm 3A$  with Sliding Mode controller, the DC bus voltage control presents good dynamic and static characteristics without overshoot. When the unbalanced loads, the voltage converges to the given value with a short time adjustment.

Figs. 5 and 7 Illustrates the Harmonic spectrum of source current for the two theories, before unbalanced loads, total harmonic distortion (THD) is 1.19% with PI control and 0.87% with SMC, when after a 1.91% with PI control and 1.77% with SMC.

**Table 3** gives the THD and amplitude of neutral wire current comparison between the two control techniques PI and SMC using Matlab/ Simulink.

**Table 3**  
*Comparison of the different techniques.*

	Before unbalanced loads		After unbalanced loads	
	PI control	SM control	PI control	SM control
Source current THD %	1.19%	0.87%	1.91%	1.77%
The amplitude of the neutral current (A)	$\pm 6A$		$\pm 3A$	

## 6 Conclusion

In this work we studied and verified with the simulation of a nonlinear sliding mode control technique for reference harmonic currents and DC bus voltage regulation based on Synchronous Reference Frame (SRF) theory and three dimensional space vector modulation (3D SVM), to generate reference harmonic currents and switching signals respectively, for a four leg shunt active power filter, have shown high performance of four leg shunt active power filter to eliminated zero sequence current, fixed switching frequency, reduced magnitude of neutral current, and power factor correction in the three phase four wire network.

The obtained simulation results of these SAPF with sliding mode control shows the four leg shunt active power filter under unbalanced loads is capable to compensate harmonic currents, reactive power, eliminated zero sequence current, and also shows better dynamic performance over conventional PI controller.

## 7 References

- [1] A. Chaoui, J. P. Gaubert, F. Krim, G. Champenois: PI Controlled Three Phase Shunt Active Power Filter for Power Quality Improvement, *Electric Power Components and Systems*, Vol. 35, No. 12, Dec. 2007, pp 1331 – 1344.
- [2] A. Chebabhi, M.K. Fellah, N. Rouabah, DJ. Khodja: Control of a Shunt Active Filter by the Direct Power Control Technique based on Virtual Flux, 7th Conference on Electrical Engineering, Bordj El Bahri, Algeria, 12-13 April 2011. (In French).
- [3] A. Chebabhi, M.K. Fellah, M.F. Benkhoris: Application of PQR Theory for Control of a 3-phase 4-wire 4-legs Shunt Active Power Filter in the  $\alpha\beta$ -axes using 3d-SVM Technique, *Leonardo Journal of Sciences*, Vol. 14, No. 26, Jan/June 2015, pp. 17 – 28.
- [4] M. Odavic, V. Biagini, P. Zanchetta, M. Sumner, M. Degano: One-sample-period-ahead Predictive Current Control for High-performance Active Shunt Power Filters, *IET Power Electronics Electronics*, Vol. 4, No. 4, April 2011, pp. 414 – 423.
- [5] A. Bhattacharya, C. Chandan: A Shunt Active Power Filter with Enhanced Performance using ANN-based Predictive and Adaptive Controllers, *IEEE Transactions on Industrial Electronics*, Vol. 58, No. 2, Feb. 2011, pp. 421 – 428.
- [6] H. Kouara, A. Chaghi: Three Phase Four Wire Shunt Active Power Filter based Fuzzy Logic DC-Bus Voltage Control, *Acta Technica Corviniensis, Bulletin of Engineering*, Vol. 5, No. 4, Oct/Dec. 2012, pp. 25 – 31.
- [7] F. Zhuo, Y. Wang, H. Li, Z.A. Wang: Study on Active Power Filter used for Three-Phase Four-Wire System, *International Power Electronics and Motion Control Conference*, Vol. 3, 15-18 Aug. 2000, pp. 1037 – 1040.
- [8] F. Zhuo, Y. Wang, Z.A. Wang: The Configuration of Main Circuit and Control Strategy for Active Power Filter in Three-phase Four-wire System, *Power Electronics Specialists Conference, Vancouver, Canada*, 17-21 June 2001, Vol. 3, pp. 1615 – 1618.
- [9] M. Aredes, E.H. Watanabe: New Control Algorithms for Series and Shunt Three-phase Four-Wire Active Power Filters, *IEEE Transactions on Power Delivery*, Vol. 10, No. 3, July 1995, pp. 1649 – 1656.
- [10] P. Cheng, Y. Huang, C. Hou: Design of a Neutral Harmonic Mitigator for Three-phase Four-wire Distribution System, *Industry Applications Conference, Chicago, IL, USA*, 30 Sept. – 04 Oct. 2001, Vol. 1, pp. 164 – 171.
- [11] S.H. Hosseini, T. Nouri, M. Sabahi: Power Quality Enhancement using a New Hybrid Active Power Filter under Non-ideal Source and Load Conditions, *IEEE Power & Energy Society General Meeting, Calgary, Canada*, 26-30 July 2009.
- [12] L. Bin, T. Minyong: Control Method of the Three-phase Four-leg Shunt Active Power Filter, *Energy Procedia*, Vol. 14, 2012, pp. 1825 – 1830.
- [13] A. Chebabhi, M.K. Fellah, M.F. Benkhoris: Control of the Three Phase Four-wire Four-leg SAPF using 3D-SVM based on the Two Methods of Reference Signals Generating CV and SRF in the dqo-axes, *Journal of Electrical Engineering*; Vol.15, No. 1, 2015, pp. 32 – 39.
- [14] N. Mendalek, K. Al-Haddad, H.Y. Kanaan, G. Hassoun: Sliding Mode Control of Three-phase Four-leg Shunt Active Power Filter, *IEEE Conference on Electrical and Computer Engineering, Canadian, Rhodes, Greece*, 15-19 June 2008, pp. 4362 – 4367.
- [15] L. Xiangsheng, Z. Deng, Z. Chen, Q. Fei: Analysis and Simplification of Three-dimensional Space Vector PWM for Three-phase Four-leg Inverters, *IEEE Transactions on Industrial Electronics*, Vol. 58, No. 2, Feb. 2011, pp. 450 – 464.

- [16] J. Zhou, X.Wu, Y. Geng, P. Dai: Simulation Research on a SVPWM Control Algorithm for a Four-leg Active Power Filter, *Journal of China University of Mining and Technology*, Vol. 17, No. 4, Dec. 2007, pp. 590 – 594.
- [17] P. Kanjiya, V. Khadkikar, H.H. Zeineldin: A Noniterative Optimized Algorithm for Shunt Active Power Filter under Distorted and Unbalanced Supply Voltages, *IEEE Transaction on Power Electronics*, Vol. 60, No. 12, Dec. 2013, pp. 5376 – 5390.
- [18] A.S.A. Hasim, M.H.N. Talib, Z. Ibrahim: Comparative Study of Different PWM Control Scheme for Three-phase Three-wire Shunt Active Power Filter, *IEEE International Conference on Power Engineering and Optimization*, Melaka, Malaysia, 06-07 June 2012, pp. 119 – 123.
- [19] C.S. Lam, X.X. Cui, M.C. Wong, Y.D. Han: Minimum DC-link Voltage Design of Three-phase Four-wire Active Power Filters, *13th Workshop on Control and Modeling for Power Electronics*, Kyoto, Japan, 10-13 June 2012, pp. 1 – 5.
- [20] C. Ravikiran, G.I. Kishore, T.A. Rao, M. Rambabu: Effective Elimination of Harmonics by means of a Hybrid Series Active Filter (HSAF), *International Journal of Engineering Research and Applications*, Vol. 2, No. 5, Sept/Oct. 2012, pp. 96 – 101.
- [21] L. Wei, L. Chunwen, X. Changbo: Sliding Mode Control of a Shunt Hybrid Active Power Filter based on the Inverse System Method, *International Journal of Electrical Power and Energy Systems*, Vol. 57, May 2014, pp. 39 – 48.
- [22] F. Hamoudi, A. Chaghi, M. Adli, H. Amimeur: A Sliding Mode Control for Four-wire Shunt Active Filter, *Journal of Electrical Engineering*, Vol. 62, No. 5, 2011, pp. 267 – 273.
- [23] J. Fei, T. Li, S. Zhang: Indirect Current Control of Active Power Filter using Novel Sliding Mode Controller, *13th Workshop on Control and Modeling for Power Electronics*, Kyoto, Japan, 10-13 June 2012, pp. 1 – 6.
- [24] E.J. Acordi, L.B.G. Campanhol, S.A.O. Silva, C.B. Nascimento, A. Goedel: A Study of Shunt Active Power Filters Applied to Three-phase Four-wire Systems, *International Conference on Renewable Energies and Power Quality*, Santiago de Compostela, Spain, 28-30 March 2012.
- [25] A. Chebabhi, A. Meroufel, N. Rouabah, A. Telli: Nonlinear Sliding Mode Control of an Asynchronous Machine, *International Conference on Electrical Engineering*, Oran, Algeria, 2010. (In French).
- [26] A. Nasri, A. Hazzab, I. Bousserhane, S. Hadjeri, P. Sicard: Two Wheel Speed Robust Sliding Mode Control for Electric Vehicle Drive, *Serbian Journal of Electrical Engineering (SJEE)*, Vol. 5, No. 2, Nov. 2008, pp. 199 – 216.
- [27] K. Negadi, A. Mansouri, B. Khtemi: Real Time Implementation of Adaptive Sliding Mode Observer Based Speed Sensorless Vector Control of Induction Motor, *Serbian Journal of Electrical Engineering*, Vol. 7, No. 2, Nov. 2010, pp. 167 – 184.
- [28] K. Bhattacharjee: Design and Simulation of Synchronous Reference Frame based Shunt Active Power Filter using Simulink, *National Conference on Challenges in Research and Technology in the Coming Decades*, Ujire, India, 27-28 Sept 2013, pp: 1-7.
- [29] K. Bhattacharjee: Harmonic Mitigation by SRF Theory based Active Power Filter using Adaptive Hysteresis Control, *Conference Power and Energy Systems: Towards Sustainable Energy*, Bangalore, India, 13-15 March 2014, pp. 1 – 6.