

# Characteristics of Switched Reluctance Motor Operating in Continuous and Discontinuous Conduction Mode

Martin P. Čalasan<sup>1</sup>, Vladan P. Vujičić<sup>1</sup>

**Abstract:** This paper presents mechanical characteristics of Switched Reluctance Motor (SRM) when it operates in Discontinuous Conduction Mode (DCM) or in Continuous Conduction Mode (CCM), i.e. when the current through the phase coils (windings) flows discontinuously or continuously. Firstly, in order to maximize the output power of SRM optimization of its control parameters was performed, such that the peak and RMS values of the current do not exceed the predefined values. The optimal control parameters vs. rotation speed, as well as the corresponding characteristics of torque, power and efficiency. It is shown that with CCM the machine torque (power), at high speed, can be increased.

**Keywords:** Switched reluctance motor, DCM, CCM, Mechanical characteristics.

## 1 Introduction

Switched Reluctance Motor (Switched Reluctance Motor – SRM) is one of the oldest and constructional simplest electrical machines. However, despite its simplicity, the use, intensive research and testing their performance becomes actual only in recent decades, with the development of power electronics. This is understandable having in mind that SRM can operate properly only if some kind of power converter and control logic are employed. The control logic provides activation signals for the power semiconductor switches in the bridge converter that are synchronized with the rotor position, [1].

The main area of application of SRM is in household applications (vacuum cleaners, washing machines, etc.) [1], in hybrid and electric vehicles [2], in wind power plant [3], in aeronautical applications [4], etc. Speed range in which this motor can develop constant power is very important for the area of application of this machine. The constant power region width depends on the motor geometry, power converter topology, and the applied control technique [1]. The relation between the motor geometry and the constant power region width is given in [5]. Also, the certain converter topologies can provide the constant power range extension [6]. On the other hand, the asymmetrical

---

<sup>1</sup>University of Montenegro, Faculty of Electrical Engineering, Džordža Vašingtona bb, 81000 Podgorica, Montenegro; E-mails: martinc@ac.me, vladanv@ac.me

configuration of SRM with an unequal number of turns per motor phases can also provide the power-range extension, which is experimentally and through a simulation verified [7]. The results of investigations presented in [8 – 10] show that increasing of the constant power rang and also the machine power can be obtained if SRM operates in continuous conduction mode at high rotor speeds.

In this paper, the difference between continuous and discontinuous Conduction operation Mode of SRM will be theoretically explained. After that, attention will be paid to the optimization of control parameters of the available SRM, in order to maximize the output power. Typical phase current and flux linkage waveforms for both mode of operation (CCM and DCM) will be presented, too. Finally, the obtained characteristics, such as the maximized power and torque, the optimal turn-on and turn-off angles, and the efficiency of the machine, as functions of rotor speed, will be presented and discussed.

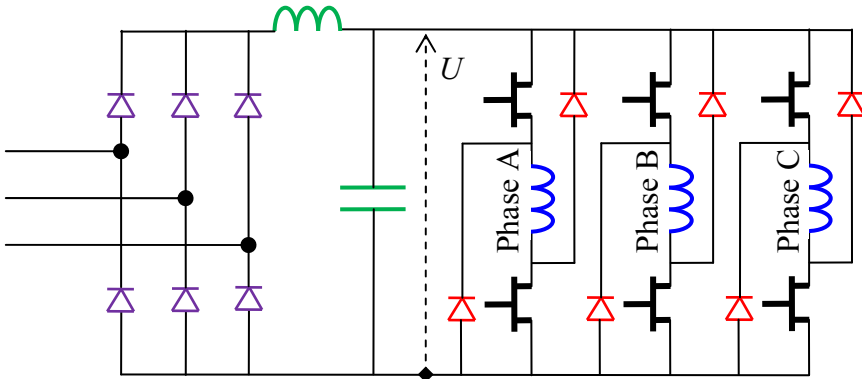


Fig. 1 – The classic converter for three-phase SRM.

## 2 Continuous and Discontinuous Conduction Mode of SRM

As it noted in the introduction, the SRM operation is impossible without power converter and controller logic. The classical scheme of three-phase SRM power converters, together with input diode rectifier, is presented on Fig. 1. This converter consists of two power switches and two diodes per motor phase. During the magnetization process, the semiconductor switches are activated, and the phase voltage is  $+U$ , which forces current flow through a phase. When it is necessary to stop the current flow through the phase (demagnetization process), it is necessary to turn off both switches. In these situations, current flows through the diodes, and the phase voltage is  $-U$ . Slower current decay can be achieved if only one of the semiconductor switches is turned off, (thus) allowing current to flow through the second switch and one of

diodes. Except the classical topology, there are numerous other types of converters [6].

The SRM control is carried out by making the corresponding synchronization between the rotor position ( $\theta$ ) and the phase current pulses. The current will cause the positive torque in the interval when the motor phase inductance increases ( $dL/d\theta > 0$ ), or regenerative (braking) torque in the interval when the inductance decreases ( $dL/d\theta < 0$ ). SRM drive performances depend on turn-on and turn-off angles, and amplitude of the phase current. Therefore, they are called control parameters of SRM. Controlling these parameters, it is possible to realize three modes of SRM control: *the constant torque mode* (at low-speed rotation, and then the current value is controlled), *the constant power mode* (for higher speed – turn-off and turn-on angles are controlled) and *regime where a torque changes inversely proportional to the square of the speed* (high speed rotation – the control angles are constant). In this last mode of operation, motor work at natural characteristics, which is equivalent to the mechanical characteristics of serial DC motor. The results which are presented in [2] show that the maximum output power significantly varies inside theoretically constant power range. The constant power region can be established with asymmetrical power supply, or by asymmetrical configuration of motor [7]. However, the maximum power that the motor can develop is reduced.

The conventional method for SRM operation may be called discontinuous conduction mode (DCM): the current in each motor winding starts at zero and returns to zero during each stroke. At constant power range, when the motor speed increases, the electromotive force also increases causing the reduction of the rms current. Therefore, with the increase of speed, it is necessary to change the control angles in order to hold the rms current at some constant value. If the constant rms current can be provided then the motor power will be constant.

Unlike the discontinuous mode, in the continuous mode (Continuous Conduction Mode – CCM) current continuously flows through the motor phase winding. Schofield [8] has showed that, in the case when SRM operates in continuous mode, constant power range can be increased more than 10 times. Also, investigations carried out by Hannoun [9 – 10] show that in the case when the current through the motor phases is continuous, torque and power can be improved at high speeds of rotation. However, in these papers the optimization procedure and the optimization conditions are not described. For this reason, the optimization process of control parameters for the tested three-phase 6/4 SRM, in both operating modes, is described in this paper.

### 3 Optimization of SRM Control Parameters in Discontinuous and Continuous Operation Mode

For determination of the optimal control parameters the computer simulations are used. The simulations were performed using the developed program, based on appropriate nonlinear mathematical model of SRM [11]. The program provides torque and phase current waveforms as well as the average torque, peak and RMS phase current values. Phase current ( $i$ ) is defined as function of flux linkage ( $\Psi$ ) and rotor position ( $\theta$ ):

$$i(\theta, \Psi) = i_0(\theta, \Psi) + i_{Fe}(\Psi), \quad (1)$$

where

$$i_0 = c_{05} \left[ (1 - c_{01})\Psi - c_{01}c_{02} + c_{01}\sqrt{(\Psi - c_{03})^2 + c_{04}^2} \right] \quad (2)$$

and

$$i_{Fe} = c_{Fe1}\Psi + c_{Fe2}\Psi^\alpha. \quad (3)$$

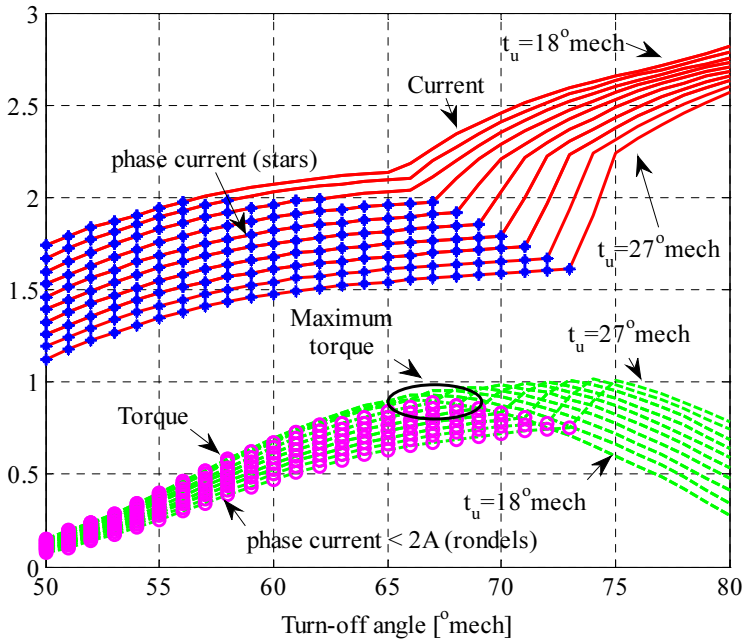
The coefficients  $c_{0j}$  ( $j = 1, 2, \dots, 5$ ) are functions of  $\theta$ , while the coefficients  $\alpha$ ,  $c_{Fe1}$ ,  $c_{Fe2}$  in (3) are constants. All these coefficients depend on the geometry of the motor, number of turns per motor phases, characteristics of the magnetic core, etc. Flux linkage is calculated from the equation:

$$\Psi = \int_0^t (u - Ri) dt, \quad (4)$$

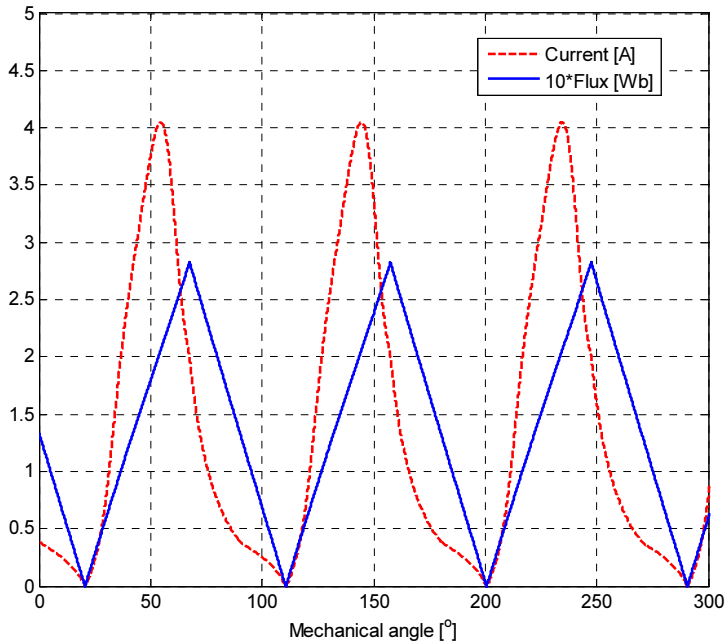
where  $u$  is the voltage applied to the phase winding,  $R$  is the phase resistance, and  $i$  is the phase current obtained from (1) for previous rotor position  $\theta - \Delta\theta$ .

Computer simulations for SR motor, whose data are given in APENDIX, from  $n = 500$  r/min to  $n = 15000$  r/min, with step of 500 r/min, are performed. For any of these speeds, the control parameters have been varied and average output torque (power) and RMS phase current were observed. Analyzing the results, the optimal control parameters (optimal turn-on and turn-off angle, as well as the reference current) were determined. Optimal parameters provide that rms and peak values of the phase current do not exceed the predetermined maximums of 2 A and 4.15 A, respectively. For low-speed rotation, discontinuous conduction mode was only analyzed, whereas for high speed rotation discontinuous and continuous operation modes were analyzed.

The phase current and torque vs. turn-off angle, for various values of turn-on angle (marked with  $t_u$ ) at 7000 r/min in discontinuous conduction mode are presented in Fig. 2. In this figure, the torques which correspond to the effective value of the current less than 2 A are marked. From this figure it is clear that, for this speed of rotation, when the turn-off angle is between  $64^\circ\text{mech}$  and  $70^\circ\text{mech}$ , the torque have a maximum value.



**Fig. 2** – The phase current and torque vs. turn-off angle, for various values of turn-on angle (marked with  $t_u$ ) at the speed of 7000 r/min discontinuous conduction mode.



**Fig. 3** – The phase current and the flux linkage in DCM.

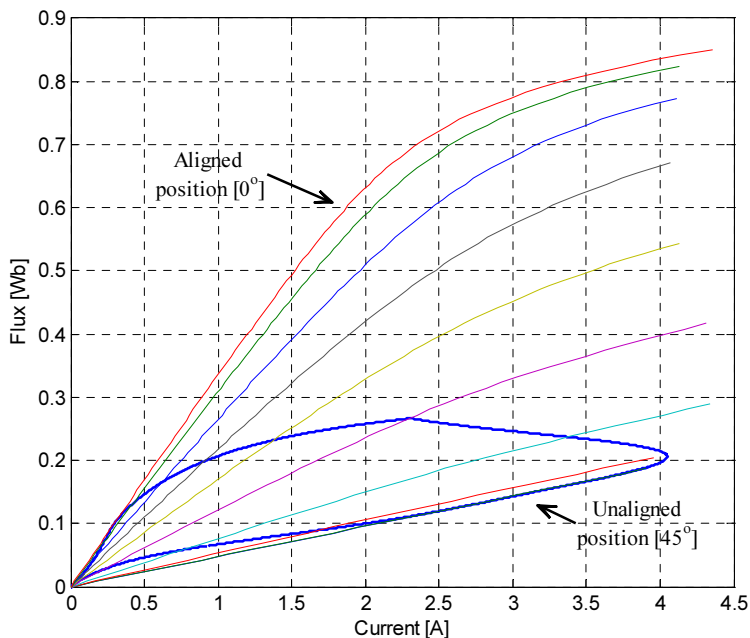


Fig. 4 – The flux linkage – current loop in DCM.

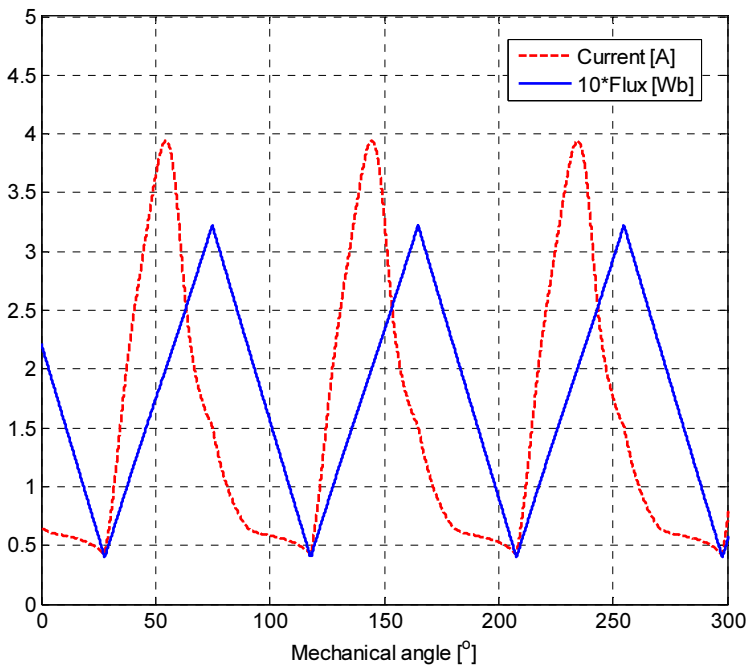
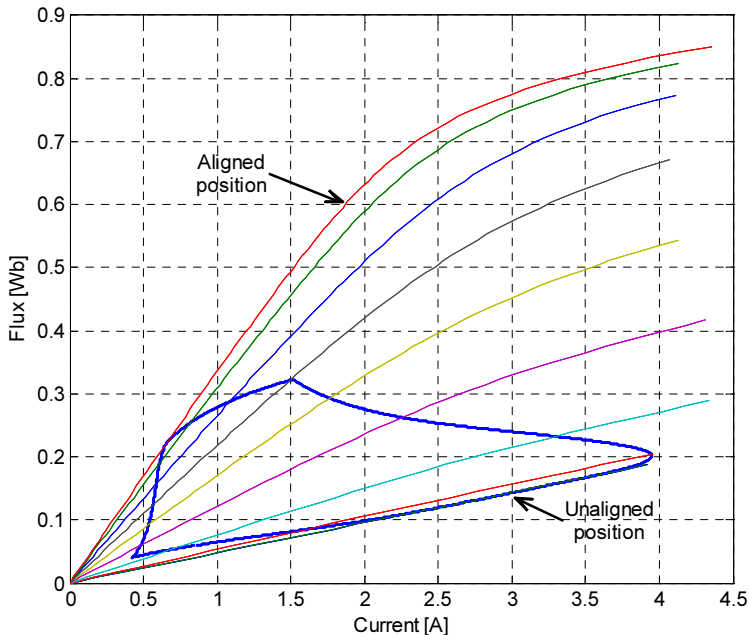


Fig. 5 – The phase current and flux linkage when SRM operates in CCM.



**Fig. 6** – The flux linkage – current loop in CCM.

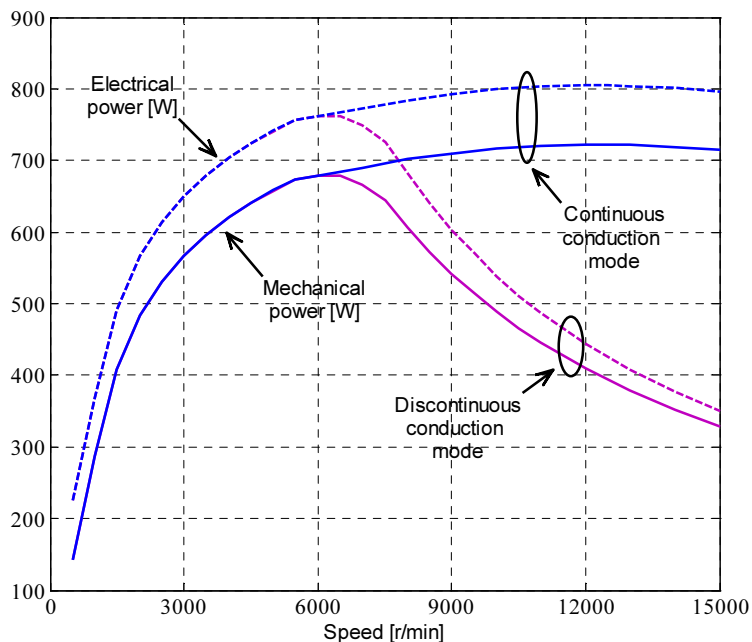
The SRM phase currents and flux linkage waveforms in discontinuous conduction mode at 7000 r/min, and at the optimum turn-on and turn-off angle of  $20.8$  [ $^{\circ}\text{mech}$ ] and  $65$  [ $^{\circ}\text{mech}$ ], respectively, are shown in Fig. 3. In this case, the rms value of the phase current is 2 A, whereas the developed power is 666.95 W. From this figure it is more than clear that flux linkage waveform have triangular shape which is expected because of low phase resistance.

The flux linkage -current loop in this operation mode is presented on Fig. 4 (at the aligned position the stator and rotor poles are overlapped; the unaligned position is shifted by 45 mech. degrees relative to the aligned position).

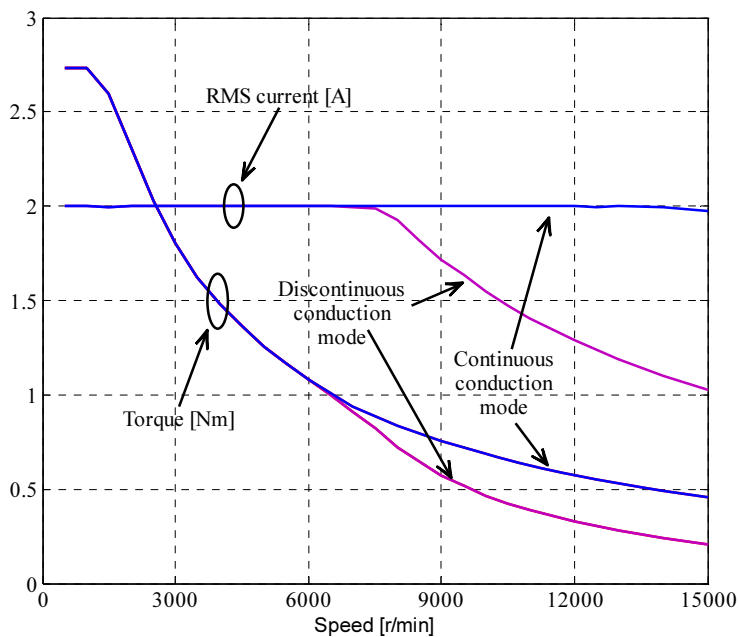
The waveforms of the SRM phase current and flux linkage in CCM at 7000 r/min, when the optimal turn-off angle is  $74.9$  [ $^{\circ}\text{mech}$ ] and turn-on angle is  $27.9$  [ $^{\circ}\text{mech}$ ], is shown in Fig. 5. In this case, rms current is 2 A, whereas the developed power is 689.92 W.

The flux linkage – current loop in DCM is presented in Fig. 6.

Looking at the above data obtained for DCM and CCM, it is clear that the CCM can provide higher output power than the DCM, even though the rms current (and therefore the ohmic loss) is not increased.

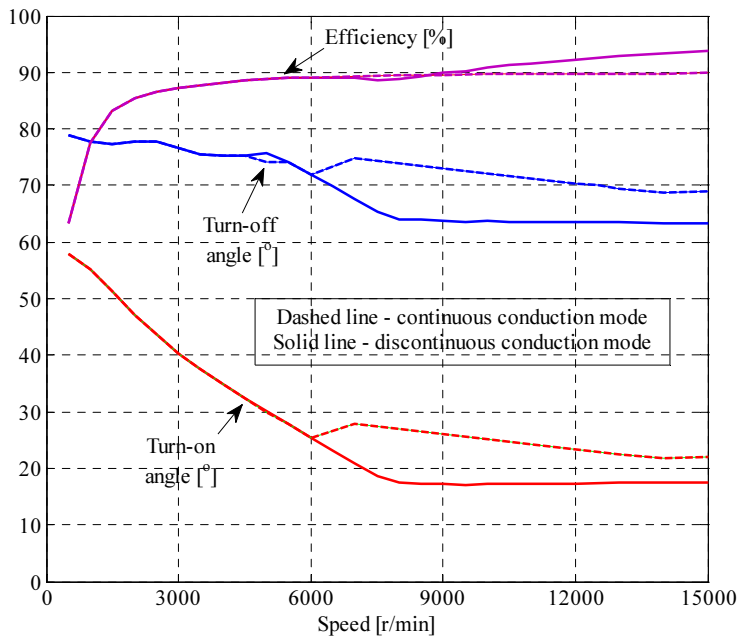


**Fig. 7** – Electrical and mechanical power vs. speed of rotation in CCM and DCM.



**Fig. 8** – The RMS phase current and torque vs. speed of rotation in CCM and DCM.





**Fig. 9** – The efficiency, turn-off and turn-on angle vs. speed of rotation in CCM and DCM.

Mechanical and electrical maximum power vs. speed of rotation is presented in Fig. 7. Torque-speed and RMS phase current-speed curves, for both operation modes, are shown in Fig. 8. The optimal turn-off and turn-on angle vs. speed of rotation relationships for these two modes are shown in Fig. 9, as well as the corresponding characteristics of efficiency. Note that in the optimization process only the copper losses are considered, since the iron losses are neglected.

It is clear from Figs. 7 and 8 that, for speed higher than 6000 r/min, the CCM provides higher output power than the DCM. For example, at 15000 r/min, the developed power in CCM is two times higher than in DCM. On the other hand, if the speed is below 9000 r/min, the efficiency of the considered SRM is approximately the same for both modes of operation. At higher speeds the efficiency is slightly higher when SRM operates in DCM, but the developed power is significantly reduced (Fig. 7).

#### 4 Conclusion

In this paper the characteristics of the SRM when it operates in continuous and discontinuous conduction mode are analyzed. In order to maximize the output power, the SRM control parameters were optimized. For both mode of

operation, the optimal control parameters, as well as the corresponding torque, power and efficiency, were defined as functions of motor speed.

Considering and comparing the obtained results for these two modes of operation, it can be concluded that continuous mode can provide significantly higher power of SRM at high speeds of rotation.

In further work on this field, it is necessary to examine the impact of hysteresis losses and losses due to eddy currents on the characteristics of SRM.

## 5 Appendix

**Table 1**  
*Some parameters of the considered SRM motor.*

Number of rotor poles	4
Number of stator poles	6
Number of turns per pole	590
Stator pole arc	32°
Rotor pole arc	30°
Air gap length	0.5mm
Stator outer diameter	116mm
Stator length	48mm
Stator pole height	105mm
Rotor pole height	21mm
Shaft diameter	19mm
Unaligned inductance	48mH

## 6 References

- [1] T.J.E. Miler: Switched Reluctance Motor and their Control, Magna Physics Publishing, Hillsboro, OH, USA 1993.
- [2] K.M. Rahman, B. Fahimi, G. Suresh, A.V. Rajarathnam, M. Ehsani: Advantages of Switched Reluctance Motor Applications to EV and HEV: Design and Control Issues, IEEE Transactions on Industry Applications, Vol. 36, No. 1, Jan/Feb. 2000, pp. 111 – 121.
- [3] R. Cardenas, R. Pena, M. Perez, J. Clare, G. Asher, P. Wheeler: Control of a Switched Reluctance Generator for Variable-speed Wind Energy Applications, IEEE Transactions on Energy Conversion, Vol. 20, No. 4, Dec. 2005, pp. 781 – 791.
- [4] Q. Ming, D. Lei, H. Xiaojiang, L. Xiaozhong: A Rapid Design Method for High Speed Aeronautic Switched Reluctance Generator, International Conference on Electric Information and Control Engineering, Wuhan, China, 15 – 17 April 2011, pp. 1937 – 1941.
- [5] J. Faiz, J.W. Finch: Aspects of Design Optimization for Switched Reluctance Motors, IEEE Transaction on Energy Conversion, Vol. 8, No. 4, Dec. 1993, pp. 704 – 713.
- [6] S. Vukosavić, V.R. Stefanović: SRM Inverter Topologies: A Comparative Evaluation, IEEE Transactions on Industry Applications, Vol. 27, No. 6, Nov/Dec. 1991, pp. 1034 – 1047.
- [7] V.P. Vujicic, S.N. Vukosavic, M.B. Jovanovic: Asymmetrical Switched Reluctance Motor for a Wide Constant Power Range, IEEE Transactions on Energy Conversion, Vol. 21, No. 1, March 2006, pp. 44 – 51.

- [8] N. Schofield, S.A. Long, D. Howe, M. McClelland: Design of a Switched Reluctance Machine for Extended Speed Operation, IEEE Transactions on Industry Applications, Vol. 45, No. 1, Jan/Feb. 2009, pp. 116 – 122.
- [9] H. Hannoun, M. Hilaret, C. Marchand: Design of an SRM Speed Control Strategy for a Wide Range of Operating Speeds, IEEE Transactions on Industrial Electronics, Vol. 57, No. 9, Sept. 2010, pp. 2911 – 2921.
- [10] H. Hannoun, M. Hilaret, C. Marchand: Experimental Validation of a Switched Reluctance Machine Operating in Continuous-conduction Mode, IEEE Transactions on Vehicular Technology, Vol. 60, No. 4, May 2011. pp. 1453 – 1460.
- [11] V.P. Vujičić, S.N. Vukosavić: A Simple Nonlinear Model of the Switched Reluctance Motor, IEEE Transactions on Energy Conversion, Vol. 15, No. 4, Dec. 2000. pp. 395 – 400.