

## Software Solution for Control and Data Acquisition in the Pulse Calorimetry Method

Marijana Babić<sup>1</sup>, Nenad Milošević<sup>1</sup>, Nenad Stepanić<sup>1</sup>

**Abstract:** This work presents a software solution for adjusting, controlling, displaying, and acquiring parameters and data in the pulse calorimetry experimental technique for specific heat capacity, electrical resistivity, total hemispherical emissivity, and normal spectral emissivity measurements. The software has been developed under the LabVIEW platform, V.7.11, and an example of its application with measurement results is presented in a separate section. The total expanded uncertainty of obtained results for the specific heat capacity and electrical resistivity of palladium was 5% and 1 – 2%, respectively.

**Keywords:** Pulse calorimetry method, Thermophysical properties, LabVIEW.

### 1 Introduction

Reliable information on thermophysical properties of pure metals and alloys such as specific heat capacity, electrical resistivity, total hemispherical emissivity, and normal spectral emissivity is essential for an efficient and economical design of all processes involving heat transfer. Problems involving the heat transfer in electronics, laser applications, high-energy devices or in power generation, energy conversion, and energy storage systems usually require the selection of materials with corresponding values of their thermophysical properties.

The direct pulse heating method for the measurement of thermophysical properties of metals and alloys over a wide temperature range has been used at the Institute of Nuclear Sciences „Vinča” since early eighties. Corresponding experimental apparatus was built on the basis of the millisecond pulse technique which was developed in the US Bureau of Standards [1, 2] in 1970. In last three decades, this apparatus has been technically improved many times, so today its measurement temperature range extends from 250 to 2600 K.

In order to improve the functionality of this experimental technique and furthermore to make experiment easier to perform a software solution under the LabVIEW platform for the control, acquisition and display of measuring signals was developed. A particular feature of using the LabVIEW code is programming

---

<sup>1</sup>Institute of Nuclear Science “Vinča”, University of Belgrade, P.O. box 522, 11001 Belgrade, Serbia;  
E-mail: marijanab@vinca.rs

in two parallel windows. First of them, which is called the Front Panel, serves as a graphical user interface. This window contains controls, switches, indicators, displays, graphics, and other elements as a part of conventional measurement devices, such as oscilloscope or voltmeter. The second window, Block Diagram, is the place where the visual programming is carried out. Front panel objects appear as terminals on the block diagram. The terminals and functions of the LabVIEW code are connected with lines, which symbolically represent the data flow.

In this paper, the basis of the experimental method, the description of developed software solution, and an example of its application with obtained results are presented consecutively.

## 2 The Experimental Method

A simple block scheme of the apparatus used for the pulse calorimetry method [3] is shown in Fig. 1. The principle of this experimental method is based on heating an electro-conductive specimen by electric current pulse of short duration. Electrical signals, representing current through the specimen, voltage drop across the “effective” specimen zone, electromotive force of the thermocouples located in the specimen centre, and response from the pyrometer, are all collected during the heating and initial part of cooling period. As a result of applied data reduction, specific heat capacity, electrical resistivity, total hemispherical emissivity, and normal spectral emissivity of the specimen are obtained [4].

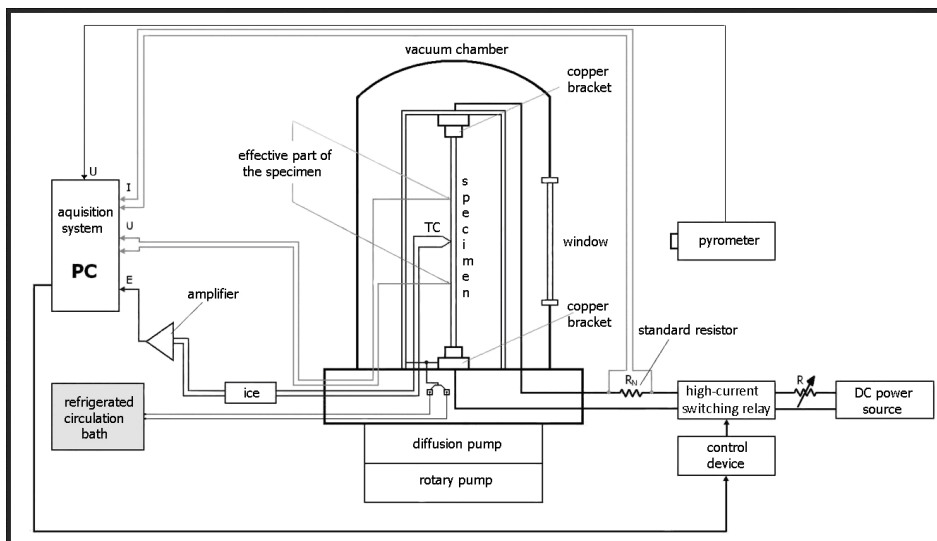
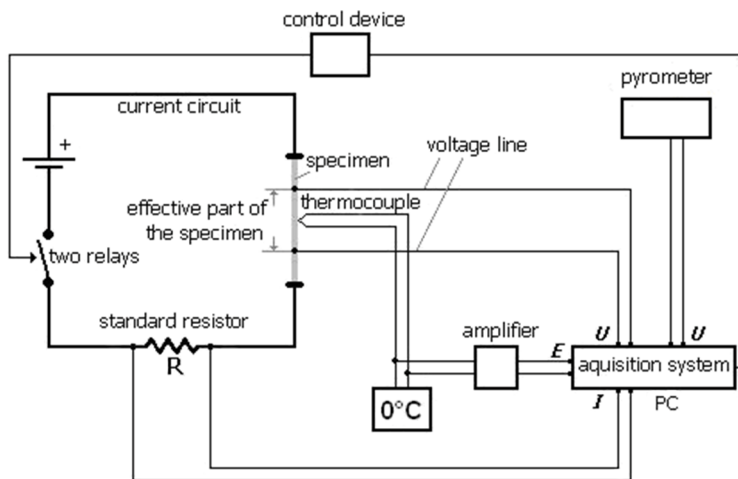

Fig. 1 – Schematic description of the apparatus.

The specimen is in the form of a thin rod (2 to 5 mm in diameter and 100 to 300 mm in length). The thermocouple hot junction is intrinsically welded on the specimen surface in the middle of the “effective” zone and measures the absolute specimen temperature at that location. The voltage leads are mounted, also by welding, on the limits of the specimen “effective” zone, typically at the distance of 10 mm and they measure the voltage drop across the specimen during the heating period, i.e., the current flow through the specimen.

The specimen is vertically placed inside the vacuum chamber, between two copper clamps, thus forming a simple current circuit with the dc power source, one standard and other adjustable resistor, and the high-current switching relay (Fig. 1). The intensity of the current flow is measured via the voltage drop on the standard  $1\text{ m}\Omega$  resistor and the radiance temperature of the specimen by the calibrated high-speed 900 nm radiation pyrometer in vicinity to the location of thermocouple. All measuring signals, i.e., thermocouple emf, voltage drop across the “effective” zone, voltage drop over the standard resistor, and pyrometer response are simultaneously recorded by the data acquisition system (Fig. 2).



**Fig. 2** – Schematic description of the measurement procedure.

The data acquisition system consists of the fast 16-bit data acquisition board (model KPCI-3116, manufactured by the KEITHLEY [5]), the screw terminal panel (model STP-3110, from the same manufacturer), the signal amplifier, and the computer. Interface between the board and the personal computer is PCI that enables a high speed data transfer which provides high measurement efficiency. The main features of this acquisition system are input measurement speed of up to 250 kS/s, 32 single ended or 16 differential analog inputs, and 2 analog outputs with waveform quality and speed of 200 kS/s.

The software developed in this paper controls the measurements of all input signals. Besides, it controls the generation of an output analog signal that is responsible for the relay switching.

### **3 Description of Software Solution**

The structure of developed software is modular and some of its parts can be used either separately or within programs of a higher level.

#### **3.1 Front panel**

The front panel of the main program consists of three different separated tabs where each one corresponds to the particular phase of measurement. A snapshot of the first tab during the working process is shown in Fig. 3.

In the first part of the program, the control and measurement of specimen temperature is conducted in order to observe the steady state phase of the related signal. Beside the graphical representation of this signal, a numerical indicator, located on the right-hand side of the panel is also applied.

Parameters which have to be set before starting the program are the type of the used thermocouple, minimal and maximal value of the expected temperature range, number of channel on which the thermocouple is connected, and desired frequency of measurement. When temperature of specimen reaches the desired level, the acquisition of the thermocouple signal is canceled by pushing the button "STOP". When the all needed experimental conditions are met, the main phase of the experiment, i.e., the heating of specimen, can begin.

The second part of the program is represented by the tab "Heating of specimen" in which several different numerical controls for the parameter adjustment are placed. Those controls are the acquisition frequency of the specimen heating and cooling phase, duration of the current pulse, acquisition time after the heating, and minimal and maximal expected voltage drop across the specimen and standard resistor. It is also needed to introduce the list of used channels of the acquisition board, as well as the name of file for the data storage.

By pressing the button "Beginning of measurement", the analog output of the acquisition board generates a signal that drives the high current switching relay. At the same time, the acquisition of the all related signals begins and typically lasts about 2 s.

The third part of the program, which is represented by the corresponding tab, is used for a preliminary test of recorded signals, mainly those related to electrical current and voltage drop. In order to provide a better visibility, all the signals are displayed by separate graphics and tabs.

# Software Solution for Control and Data Acquisition in the Pulse Calorimetry Method

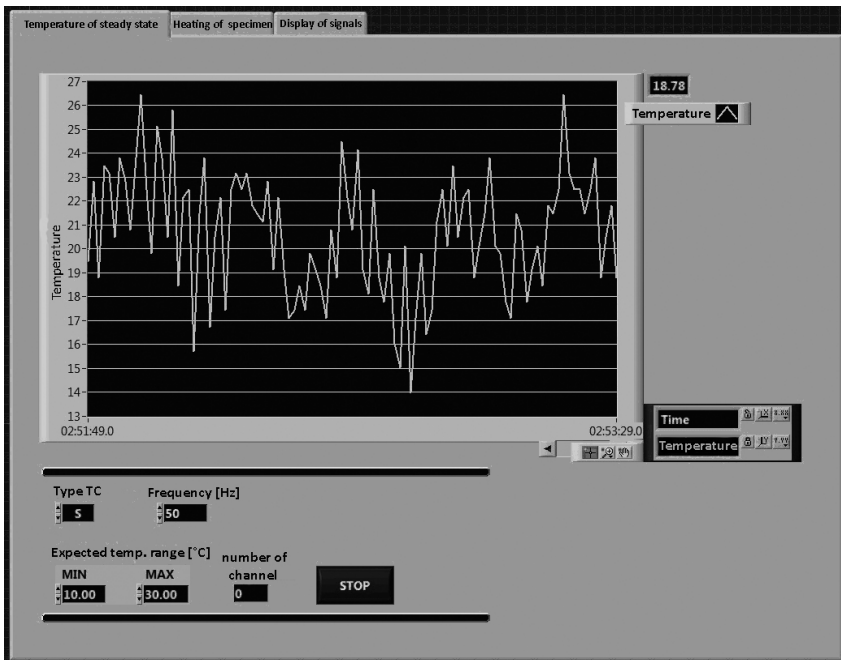

Fig. 3 – Snapshot of the front panel from the first program phase.

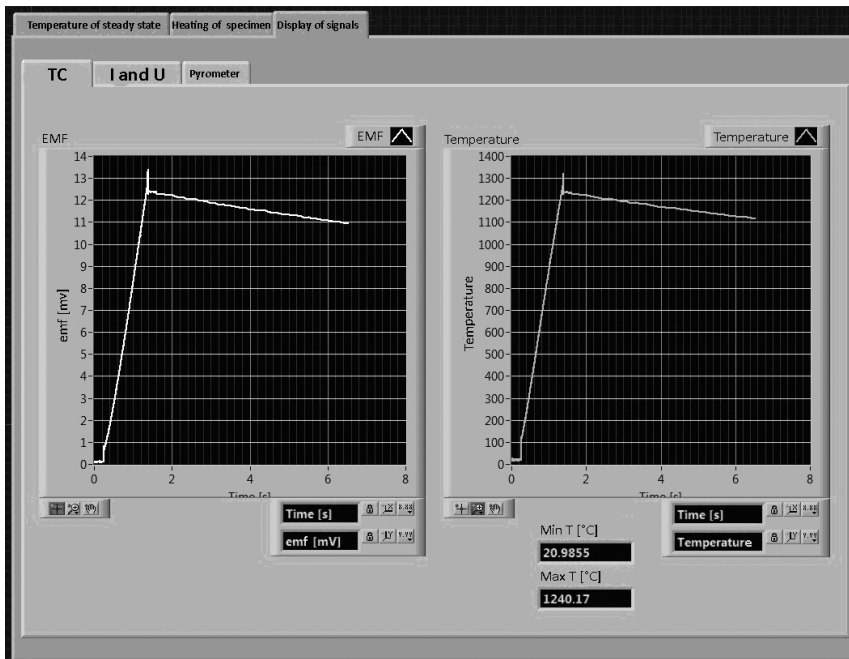

Fig. 4 – Snapshot of the front panel with an example of signal waveforms.

As shown in Fig. 4, the first group of signals refers to the values obtained by thermocouple. The evolution of the emf is presented by the graphic on the left-hand side, while corresponding temperature values obtained from the emf signal as well as their local minima and maxima are presented on the right-hand side of tab. Other graphics show the voltage drop across the “effective” zone of the specimen, current through specimen, and voltage signal of the prometer.

### 3.2 Block diagram

The block diagram is a part of the program where the code of the software solution is realized. In this work, the block diagram was developed in the form of a state machine, which consists of three phases: the temperature of the steady state, the heating of the specimen, and the display of the signals. The state machine is designed pattern in LabVIEW. The flow of the state transition diagram was implemented by the While Loop, while the individual states are represented by different options using the Case structure. The block diagram of the initial phase, i.e. “Temperature of the steady state”, is shown in Fig. 5.

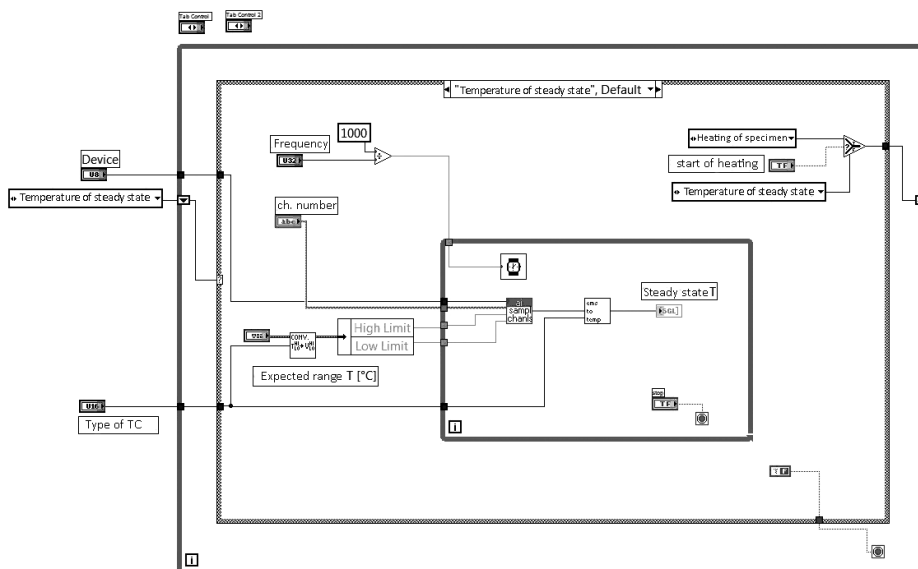

Fig. 5 – Block diagram of the main program.

In the realization of this software solution, different subprograms were used. Some of them are part of the LabVIEW platform [6], such as modules for voltage to temperature and vice versa conversion. The others are part of a particular driver, such as DriverLINX, which is obtained from the manufacturer. These subprograms control all the input and output signals of the board.

The data acquisition is on not only during the current flow through the specimen, but also before and after that period of heating. After the heating, for example, the acquisition time is about one-fifth of the time of heating and during a gradual specimen cooling the thermocouple signal is acquired according to user-defined parameters.

In the last phase of the state machine, the emf signal of the thermocouple is corrected and converted to temperature. Also, the voltage signal from the standard resistor is transformed into the current.

#### **4 An Example of the Program Application**

The software solution described in this paper was used in the experimental determination of the specific heat capacity and electrical resistivity of palladium specimens [7]. Palladium is a transition metal from the 10<sup>th</sup> group. Today, it is often called a metal of the 21<sup>st</sup> century due to its wide use in jewelry, dentistry, aircraft spark plugs, electronics, and other branches of industry. The largest use of palladium today is, however, in catalytic converters. Although palladium is very actual material, the values of its thermophysical properties have been only partially examined in the specialized literature. This was the reason why further examinations of this material are significant.

Measurements described in [7] were performed on specimens of polycrystalline palladium provided by Goodfellow, with the declared purity of more than 99.95%. The length and diameter of those specimens were about 200 and 2 mm, respectively. The temperature was measured by a thin-wire thermocouple of the S type. Considering the fact that the melting point of palladium is about 1555°C, the maximal temperature of the experiment was up to 1500°C. Performing the measurement was considerably facilitated by using the software solution, its graphical presentation of the thermocouple signal, and its other features described above.

Results of measurements, which were obtained from 12 experimental signals in the temperature range from 20 to 1500°C, are given in Fig. 6. The values of the electrical resistivity of the palladium specimen were obtained by the corresponding data reduction (Fig. 6a). The final values of the electrical resistivity were determined by averaging the data at a certain reference temperature (Fig. 6b). The total expanded uncertainty of the measurements was in the range from 1 to 2% at temperatures lower than 500°C, and less than 1% at higher temperatures.

Results of the specific heat capacity of the palladium specimens are presented in Fig. 6c. Two groups of signals acquired during the current flow in both directions can be seen on this picture. These signals intersect at the temperature of about 270°C, so the measurement uncertainty is the lowest around this temperature. The final values of the specific heat capacity of

palladium specimens were also obtained by averaging the data at a certain reference temperature (Fig. 6d) and the total expanded uncertainty was up to 5% in this case.

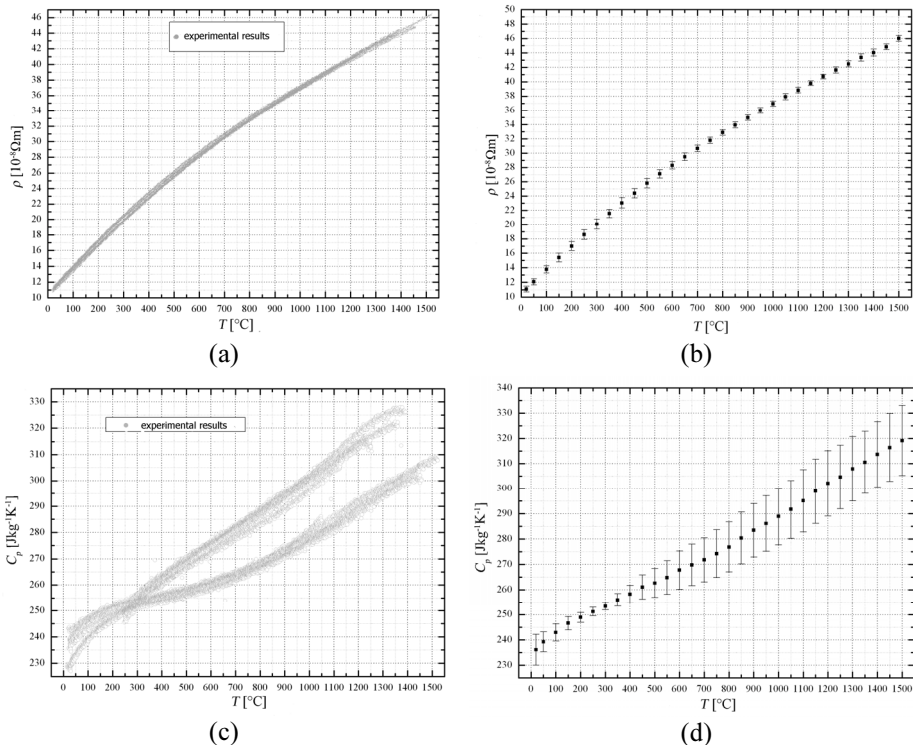

**Fig. 6** – Results of measurement: electrical resistivity and specific heat capacity of palladium in function of temperature. (a, c) Experimental data. (b, d) Final results.

## 5 Conclusion

The software solution developed in this work improves the efficiency of the data reduction in the experimental method for the determination of the specific heat capacity, electrical resistivity, total hemispherical emissivity, and normal spectral emissivity of metals and alloys over a wide temperature range. With this program, a direct control of the high current switching relay, a real-time data acquisition, and a graphical presentation of all related signals have been realized.

A higher efficiency was achieved by using the program package LabVIEW for realization of this software. The LabVIEW platform is very suitable for the development of different applications using various libraries primarily intended for engineers. Its big advantage is in its capability to communicate with almost all hardware devices.



## 6 References

- [1] A. Cezairliyan, M.S. Morse, H.A. Berman, C.W. Beckett: High-speed (Subsecond) Measurement of Heat Capacity, Electrical Resistivity, and Thermal Radiation Properties of Molybdenum in the Range 1900 to 2800 K, *Journal of Research of the National Bureau of Standards - A. Physics and Chemistry*, Vol. 74A, No. 1, Jan/Feb. 1970, pp. 65 – 92.
- [2] A. Cezairliyan: A Millisecond-resolution Pulse Heating System for Specific Heat Measurements at High Temperatures, *Compendium of Thermophysical Property Measurement Methods, Vol. 2: Recommended Measurement Techniques and Measurement Practices*, ed. K.D. Maglič, A. Cezairliyan, V.E. Peletsky, Plenum Press, New York, pp. 483 – 517, 1992.
- [3] A.S. Dobrosavljević, K.D. Maglič: Evaluation of Direct Pulse Heating Method for Measurement of Specific Heat and Electric Resistivity in the Range 300-1900 K, High Temperatures – High Pressures, Vol. 21, No. 4, pp. 411 – 421, 1989.
- [4] M. Babić, N. Milošević: A Direct Pulse Heating Method for Measurement of Thermal Properties of Metals and Alloys in a Wide Temperature Range, *Termotehnika*, Vol. 37, No. 2, 2011, pp. 211 – 222. (In Serbian).
- [5] Keithley Instruments, Inc., KPCI-3110 and KPCI-3116 PCI Bus Data Acquisition Boards, *User's Manual*, 2002.
- [6] <http://www.ni.com>.
- [7] N. Milosevic, M. Babic: Thermophysical Properties of Solid-phase Palladium in a Wide Temperature Range, 19<sup>th</sup> European Conference on Thermophysical Properties, Thessaloniki, Greece, Aug. 28 – Sept. 1, 2011.