

## Control of Multi-Machine Using Adaptive Fuzzy

Bousmaha Bouchiba<sup>1</sup>, Abdeldjebar Hazzab<sup>1</sup>,  
Hachemi Glaoui<sup>1</sup>, Fellah Med-Karim<sup>2</sup>,  
Ismail Khalil Bousserhane<sup>1</sup>, Pierre Sicard<sup>3</sup>

**Abstract:** An indirect Adaptive fuzzy excitation control (IAFLC) of power systems based on multi-input-multi-output linearization technique is developed in this paper. The power system considered in this paper consists of two generators and infinite bus connected through a network of transformers and transmission lines. The fuzzy controller is constructed from fuzzy feedback linearization controller whose parameters are adjusted indirectly from the estimates of plant parameters. The adaptation law adjusts the controller parameters on-line so that the plant output tracks the reference model output. Simulation results shown that the proposed controller IAFLC, compared with a controller based on tradition linearization technique can enhance the transient stability of the power system.

**Keywords:** Feedback linearization control, Generator excitation control, Indirect adaptive fuzzy control in multi-input multi-output.

### 1 Introduction

An interconnected power system basically consists of several essential components. They are namely the generating units, the transmission lines, the loads, the transformer, static VAR compensators and lastly the HVDC lines. During the operation of the generators, there may be some disturbances such as sustained oscillations in the speed or periodic variations in the torque that is applied to the generator. These disturbances may result in voltage or frequency fluctuation that may affect the other parts of the interconnected power system. External factors, such as lightning, can also cause disturbances to the power system. All these disturbances are termed as faults. When a fault occurs, it causes the motor to lose synchronism if the natural frequency of oscillation coincides with the frequency of oscillation of the generators. With these factors in mind, the basic condition for a power system with stability is synchronism. Besides this condition, there are other important condition such as steady-state

---

<sup>1</sup>University Center of Bechar, BP 417 bechar, Algeria, 08000; E-mail: bouchiba\_bousmaha@yahoo.fr

<sup>2</sup>University of Djillali Liabes, BP 98 Sidi Bel-Abbes, Algeria.

<sup>3</sup>Groupe de recherche en électronique industrielle, École d'Ingénierie, Département de Génie électrique et Génie informatique, Université du Québec à Trois-Rivières, Canada.

stability, transient stability, harmonics and disturbance, collapse of voltage and the loss of reactive power.

In recent years, problems associated with environmental issues and high costs have delayed the construction of new transmission lines, while the demand for electric power has continued to grow. Under these conditions, the transmission networks are called upon to operate at high transmission levels and power engineers have had to confront some major operating problems such as transient instability, poor damping of oscillations and poor voltage regulation.

While the generator excitation controllers are helpful in achieving rotor angle stability, with excitation control alone system stability may not be maintained if a large fault occurs close to the generator terminal. Moreover simultaneous transient stability and voltage regulation enhancement may be difficult to be achieved. Researchers have found that the performance of power systems can be further improved by applying the recently developed flexible AC transmission systems (FACTS) controllers [1, 2].

Different approaches for excitation control are available in literature such as excitation control based on linear control theory using small signal models of the power system [3-5] and nonlinear excitation controls based on feedback linearization (FBL) control concept [6, 7].

This paper, present an indirect adaptive fuzzy excitation control in multi-machine systems based on feedback linearization technique, the main goal is to improve both the system transient stability and damping properties even under sudden disturbances and to insure good post-fault terminal voltage.

A two-machine infinite bus example system is used to evaluate the effectiveness of the proposed control scheme. Simulation results show that the proposed control can enhance the dynamic performance of the power system over a wide range of operating conditions. The paper is organized as follows. In Section 2 the mathematical model of a multi-machine power system is presented. Feedback linearization control based on multi input multi output linearization is given in Section 3. Description of fuzzy logic systems is outlined in Section 4. In Section 5, a design of adaptive fuzzy excitation control is proposed. Simulation results are shown in section 6 and conclusion are shown in Section 7.

## **2 Mathematical Model**

Consider a large-scale power system consisting of  $n$ -generators interconnected through a transmission network. For the  $i$ -th subsystem, the dynamics can be written using the state space formulation [8]:

$$\begin{aligned} \dot{\delta}_i &= \omega_i, \\ \dot{\omega}_i &= -\frac{D_i}{2H_i}\omega_i - \frac{\omega_0}{2H_i}(P_{ei} - P_m), \\ \dot{E}'_{qi} &= \frac{1}{T_{doi}}(-E'_{qi} + (x_{di} - x'_{di})i_{di} + E_{fdi}) = \frac{1}{T_{doi}}(-E_{qi} + E_{fdi}). \end{aligned} \quad (1)$$

The electrical equations are as follows:

$$E_{qi} = E'_{qi} + (x_{di} - x'_{di})i_{di}, \quad (2)$$

$$P_{ei} = \sum_{j=1}^n E'_{qi} E'_{qj} B_{ij} \sin(\delta_i - \delta_j), \quad (3)$$

$$Q_{ei} = -\sum_{j=1}^n E'_{qi} E'_{qj} B_{ij} \cos(\delta_i - \delta_j), \quad (4)$$

$$i_{di} = -\sum_{j=1}^n E'_{qj} B_{ij} \cos(\delta_i - \delta_j), \quad (5)$$

$$i_{qi} = -\sum_{j=1}^n E'_{qj} B_{ij} \sin(\delta_i - \delta_j), \quad (6)$$

$$V_{di} = E'_{di} + i_{qi} x'_{qi}, \quad (7)$$

$$V_{qi} = E'_{qi} - i_{di} x'_{di}, \quad (8)$$

$$V_{ii} = \sqrt{V_{di}^2 + V_{qi}^2}, \quad (9)$$

$$E'_{di} = -(x_{qi} - x'_{qi})i_{qi}. \quad (10)$$

### 3 Feedback Linearization Control

The power system with subsystems modeled as in (1) can be written as a multi input-output system [9]:

$$\begin{cases} \dot{\mathbf{X}} = \mathbf{F}(x) + \mathbf{G}(x)\mathbf{U} \\ \mathbf{Y} = \mathbf{H}(x) \end{cases} \quad (11)$$

where

$$\begin{aligned} \mathbf{X} &= [x_1, x_2, \dots, x_n]^T, \\ \mathbf{U} &= [E_{fd1}, E_{fd2}, \dots, E_{fdm}]^T, \\ \mathbf{Y} &= [\delta_1, \delta_2, \dots, \delta_k]^T, \end{aligned} \quad (12)$$

where  $\mathbf{F}$  and  $\mathbf{G}$  are smooth vector fields, and  $\mathbf{G}$  is a  $n \times m$  matrix. Differentiating the output repeatedly with respect to time, the input  $\mathbf{U}$  appears explicitly after three differentiations.

$$\ddot{y}_i = \alpha_i(x) + \sum_{j=1}^n \beta_{ij}(x) E_{fdj}. \quad (13)$$

The feedback linearization and decoupling control law is given by:

$$\begin{bmatrix} E_{fd1} \\ \vdots \\ E_{fdm} \end{bmatrix} = A^{-1}(x) \begin{bmatrix} -\alpha_1(x) + v_1 \\ \vdots \\ -\alpha_m(x) + v_m \end{bmatrix}, \quad (14)$$

where

$$A(x) = \begin{bmatrix} \beta_{11}(x) & \cdots & \beta_{1m}(x) \\ \vdots & \ddots & \vdots \\ \beta_{m1}(x) & \cdots & \beta_{mm}(x) \end{bmatrix},$$

and

$$\alpha_i(x) = -\frac{D_i}{2H_i} \dot{\omega}_i - \frac{\omega_0}{2H_i} \sum_{j=1}^n E'_{qi} E'_{qj} B_{ij} (\omega_i - \omega_j), \quad (15)$$

$$\cos(\delta_i - \delta_j) + \frac{\omega_0}{2H_i} \frac{E_{qi}}{T_{doi}} \sum_{j=1}^n E'_{qj} B_{ij} \sin(\delta_i - \delta_j) + \frac{\omega_0}{2H_i} \sum_{j=1}^n \frac{E_{qj}}{T_{doj}} E'_{qi} B_{ij} \sin(\delta_i - \delta_j),$$

$$\beta_{ij}(x) = -\frac{\omega_0}{2H_i} \frac{1}{T_{doj}} E'_{qi} B_{ij} \sin(\delta_i - \delta_j), \quad (16)$$

$$\beta_{ii}(x) = -\frac{\omega_0}{2H_i} \frac{1}{T_{doi}} \sum_{j=1}^n E'_{qj} B_{ij} \sin(\delta_i - \delta_j). \quad (17)$$

Once linearization is achieved, further control objectives like model matching, pole placement and tracking can be easily met. For our purpose we would like to regulate the output to zero in a desired fashion. We choose.

$$v_i = \ddot{y}_m + a_{3i} \ddot{e}_{ri} + a_{2i} \dot{e}_{ri} + a_{1i} e_{ri}, \quad (18)$$

where

$$e_{ri} = y_{mi} - y_i = \delta_{i0} - \delta_i,$$

$$\dot{e}_{ri} = \dot{y}_{mi} - \dot{y}_i = -\omega_i,$$

$$\ddot{e}_{ri} = \ddot{y}_{mi} - \ddot{y}_i = -\dot{\omega}_i,$$

and  $a_{ji}$ ,  $j=1,2,3$ ;  $i=1,\dots,m$ , are chosen such that the polynomial  $s^2 + a_{3i}s^2 + a_{2i}s + a_{1i}$  is strict Hurwitz and the system has poles at the desired locations. The control law given by (14) and (18) results in a feedback linearized and decoupled system with the output  $y_i$  converging asymptotically to the desired response.

#### 4 Description of Fuzzy Logic Systems

The fuzzy logic systems are universal approximations from the viewpoint of human experts and can uniformly approximate nonlinear continuous functions to arbitrary accuracy. In the adaptive fuzzy control case, in order to achieve the proposed control objectives, nonlinear functions  $\alpha_i(x)$  and  $\beta_{ij}(x)$  will be approximated by tuning the parameters of the corresponding fuzzy logic systems. Therefore, the fuzzy logic systems are qualified as building blocks of adaptive fuzzy controllers for nonlinear systems. Furthermore, the fuzzy logic systems are constructed from the fuzzy IF-THEN rules using some specific inference, fuzzification, and defuzzification strategies. So linguistic information from human experts can be directly incorporated into controllers [10].

$$R^{(l)} : \text{IF } x_1 \text{ IS } F_1^l \text{ AND } x_2 \text{ IS } F_2^l \text{ AND } \dots \text{ AND } x_n \text{ IS } F_n^l \\ \text{THEN } y^l \text{ IS } C^l \quad (l=1, \dots, M),$$

where  $x = (x_1 \ \dots \ x_n)^T \in U$ ;  $y \in V \subset R$  are the input and output of fuzzy logic systems, respectively, and  $F_i^l$ ,  $C^l$  are the fuzzy sets defined on  $U_i$  and  $R$ , respectively. The fuzzy inference engine performs a mapping from fuzzy sets in  $U$  to fuzzy sets in  $R$ , based upon the fuzzy IF-THEN rules in the fuzzy rule base and the compositional rule of inference. The fuzzifier maps a crisp point  $x = (x_1 \ \dots \ x_n)^T$  into a fuzzy set in  $U$ . The defuzzifier maps a fuzzy set in  $V$  to a crisp point in  $V$ .

**Lemma 1.** The fuzzy logic systems with center-average defuzzifier; product inference and singleton fuzzifier are in the following form:

$$y(x) = \frac{\sum_{l=1}^M \bar{y}^l \left( \prod_{i=1}^n \mu_{F_i^l}(x_i) \right)}{\sum_{l=1}^M \left( \prod_{i=1}^n \mu_{F_i^l}(x_i) \right)}, \quad (19)$$

where  $\bar{y}^l$  is the point at which  $\mu_c^l$  achieves its maximum value, and we assume that  $\mu_c^l(\bar{y}^l) = 1$ . Equation (19) can be written as:

$$y(x) = \underline{\theta}^T \underline{\psi}(x), \quad (20)$$

where  $\underline{\psi}(x)$  is the fuzzy basis function defined by:

$$\psi_l(x) = \frac{\prod_{i=1}^n \mu_{F_i^l}(x_i)}{\sum_{l=1}^M \left( \prod_{i=1}^n \mu_{F_i^l}(x_i) \right)}. \quad (21)$$

## 5 Adaptive Fuzzy Exciter Based on Multi-Input Multi-Output

If the nonlinear functions  $\alpha_i(x)$ ,  $\beta_{ij}(x)$  are unknown in our problem, so obtaining control law (14) is impossible. In this situation, our purpose is to approximate  $\alpha_i(x)$ ,  $\beta_{ij}(x)$  with fuzzy logic systems  $\hat{\alpha}_i(x)$ ,  $\hat{\beta}_{ij}(x)$  defined as [11]:

$$\begin{aligned}\hat{\alpha}_i(x|\theta_i) &= \theta_i^T \Psi(x), \\ \hat{\beta}_{ij}(x|\theta_{ij}) &= \theta_{ij}^T \Psi(x).\end{aligned}\quad (22)$$

Choosing an equivalence control as:

$$\begin{bmatrix} E_{fd1} \\ \vdots \\ E_{fdm} \end{bmatrix} = \begin{bmatrix} \hat{\beta}_{11}(x) & \cdots & \hat{\beta}_{1m}(x) \\ \vdots & \ddots & \vdots \\ \hat{\beta}_{m1}(x) & \cdots & \hat{\beta}_{mm}(x) \end{bmatrix}^{-1} \begin{bmatrix} -\hat{\alpha}_1(x) + v_1 \\ \vdots \\ -\hat{\alpha}_m(x) + v_m \end{bmatrix}, \quad (23)$$

$$\ddot{e}_i = -\bar{a}^T \bar{e} + w_i, \quad (24)$$

where  $\bar{a}^T = [a_{1i} \ a_{2i} \ a_{3i}]$  and  $\bar{e} = [e_i \ \dot{e}_i \ \ddot{e}_i]$  and  $w_i$  is the approximation error defined by:

$$w_i = (\hat{\alpha}_i(x|\theta_i) - \alpha_i(x)) + \sum_{j=1}^n (\hat{\beta}_{ij}(x|\theta_{ij}) - \beta_{ij}(x)) u_j, \quad (25)$$

and its state-place equation is:

$$\dot{\bar{e}}_i = \mathbf{A}_i \bar{e}_i + \mathbf{b}_i w_i, \quad (26)$$

where

$$\mathbf{A}_i = \begin{bmatrix} 0 & 1 & 0 \\ 0 & 0 & 1 \\ -a_{1i} & -a_{2i} & -a_{3i} \end{bmatrix}, \quad \mathbf{b}_i = \begin{bmatrix} 0 \\ 0 \\ 1 \end{bmatrix}.$$

Define the optimal parameter estimates  $\theta_i^*$  and  $\theta_{ij}^*$  as follows:

$$\theta_i^* = \arg \left( \min_{\theta_i \in \Omega_i} \left[ \sup_{x \in U_c} \left\| \theta_i^T \Psi(x) - \alpha_i(x) \right\| \right] \right) \quad (27)$$

$$\theta_{ij}^* = \arg \left( \min_{\theta_{ij} \in \Omega_{ij}} \left[ \sup_{x \in U_c} \left\| \theta_{ij}^T \Psi(x) - \beta_{ij}(x) \right\| \right] \right). \quad (28)$$

Using  $\theta_i^*$  and  $\theta_{ij}^*$ , the minimum approximation error  $w_i^*$  can be written as:

$$w_i^* = (\hat{\alpha}_i(x|\theta_i^*) - \alpha_i(x)) + \sum_{j=1}^n (\hat{\beta}_{ij}(x|\theta_{ij}^*) - \beta_{ij}(x)) u_j. \quad (29)$$

Now adding and subtracting the term  $(\mathbf{b}_i w_i^*)$  to (26), the error equation can be rewritten as:

$$\dot{\bar{\mathbf{e}}}_i = \mathbf{A}_i \bar{\mathbf{e}}_i + \mathbf{b}_i w_i^* + \mathbf{b}_i \left[ \phi_i^T \psi(x) + \sum_{j=1}^n \phi_{ij}^T \psi(x) u_j \right], \quad (30)$$

where:  $\phi_i = \theta_i - \theta_i^*$  and  $\phi_{ij} = \theta_{ij} - \theta_{ij}^*$ , if the following positive definite Lyapunov function candidate [11]:

$$V_i = \frac{1}{2} \bar{\mathbf{e}}_i^T \mathbf{P} \bar{\mathbf{e}}_i + \frac{1}{2\gamma_i} \phi_i^T \phi_i + \sum_{j=1}^n \frac{1}{2\gamma_{ij}} \phi_{ij}^T \phi_{ij}. \quad (31)$$

We choose the adaptive law as

$$\begin{aligned} \dot{\theta}_i &= -\gamma_i \bar{\mathbf{e}}_i^T \mathbf{P} \mathbf{b}_i \psi(x), \\ \dot{\theta}_{ij} &= -\gamma_{ij} \bar{\mathbf{e}}_i^T \mathbf{P} \mathbf{b}_i \psi(x) u_j. \end{aligned} \quad (32)$$

From the above equation we have:

$$\dot{V}_i = -\frac{1}{2} \bar{\mathbf{e}}_i^T \mathbf{Q} \bar{\mathbf{e}}_i + \frac{1}{2} (w_i^{*T} \mathbf{b}_i^T \mathbf{P} \bar{\mathbf{e}}_i + \bar{\mathbf{e}}_i^T \mathbf{P} \mathbf{b}_i w_i^*). \quad (33)$$

The term  $\frac{1}{2} (w_i^{*T} \mathbf{b}_i^T \mathbf{P} \bar{\mathbf{e}}_i + \bar{\mathbf{e}}_i^T \mathbf{P} \mathbf{b}_i w_i^*)$  is of the order of the minimum approximation error which is very small or zero. If this is case equation (33) reduces to  $\dot{V}_i \leq 0$ , where the  $\mathbf{P}_i$  matrix is the unique positive defined  $3 \times 3$  matrix that satisfies the Lyapunov equation:

$$\mathbf{A}_i^T \mathbf{P}_i + \mathbf{P}_i \mathbf{A}_i = -\mathbf{Q}_i.$$

## 6 Simulation Results

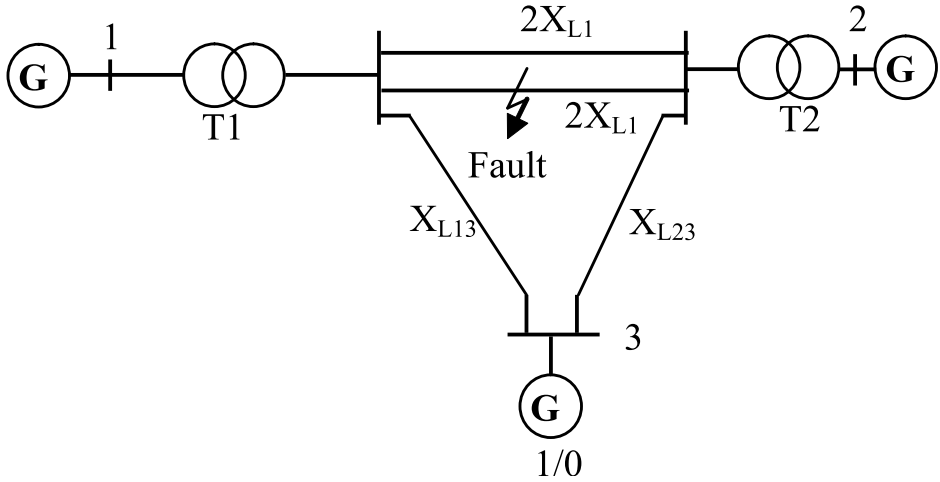
The system considered here consists of a 50 Hz, 230 kV transmission network with two generators and infinite bus connected through a network of transformers and transmission lines. The single line diagram of the system is shown in Fig. 1. The infinite bus voltage is taken as a reference.  $V_3 = 1$  (arg 0).

The parameters that are used in the power system modeling are as shown below [8]:

$$\omega_0 = 314.159, \quad X_{L12} = 0.55, \quad X_{L13} = 0.53, \quad X_{L23} = 0.6.$$

**Generator 1:**  $x_d = 1.863$  p.u.,  $x'_d = 0.257$  p.u.,  $x_q = 1.46$  p.u.,  $x'_q = 0.546$  p.u.,  
 $x_{T1} = 0.129$  p.u.,  $T_{d0} = 6.9$  p.u.,  $H = 4$  s,  $D = 5$  p.u.

**Generator 2:**  $x_d = 2.36$  p.u.,  $x'_d = 0.319$  p.u.,  $x_q = 0.70$  p.u.,  $x'_q = 0.20$  p.u.,  
 $x_{T1} = 0.110$  p.u.,  $T_{d0} = 7.96$  p.u.,  $H = 5.1$  s,  $D = 3$  p.u.



**Fig. 1** – A two machine with infinite bus power system.

The system response under a three-phase short circuit fault is tested. The following temporary fault sequence is used in the simulation studies:

- Stage 1: The system is in a per-fault steady state.
- Stage 2: A three phase short circuit fault occurs at  $t = 0.1s$ .
- Stage 3: The fault is removed by opening the circuit breakers after 0.2 s.
- Stage 4: The transmission line is restored at  $t = 1.4s$ .
- Stage 5: The system is in a post-fault state.

**CASE 1:**

The operating point is

$$\delta_{10} = 60.78, \quad P_{m10} = 0.95, \quad V_{t10} = 1.0,$$

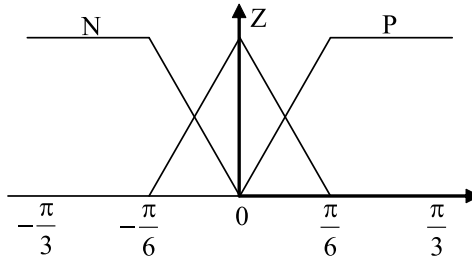
$$\delta_{20} = 60.78, \quad P_{m20} = 0.95, \quad V_{t20} = 1.0.$$

The fault location is  $\lambda = 0.1$ .

The indirect adaptive fuzzy controller is now applied to the above example, where for each state variable  $(\delta_i - \delta_{0i}, \omega_i, E'_{qi})$  we define three triangular membership functions, where  $i = 1, 2$ .

We defined three fuzzy sets for  $\delta_i - \delta_{0i}$  (Fig. 2), and three fuzzy sets for  $\omega_i$  (Fig. 3), and three fuzzy sets for  $E'_{qi}$  (Fig. 4).



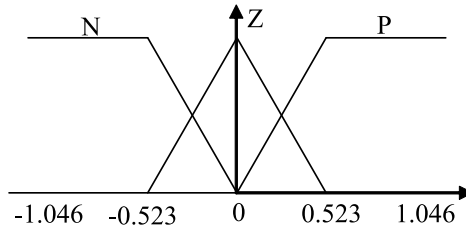


**Fig. 2** – Fuzzy membership functions for  $\delta_i - \delta_{i0}$ .

$$u_N(x_i) = 1 - \text{abs}((x_i - \pi / 6) / (\pi / 6)),$$

$$u_z(x_i) = 1 - \text{abs}((x_i) / (\pi / 6)),$$

$$u_p(x_i) = 1 - \text{abs}((x_i + \pi / 6) / (\pi / 6)).$$

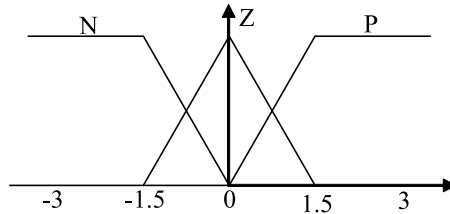


**Fig. 3** – Fuzzy membership functions for  $\omega_i$ .

$$u_N(x_i) = 1 - \text{abs}((x_i - 0.523) / (0.523)),$$

$$u_z(x_i) = 1 - \text{abs}((x_i) / (0.523)),$$

$$u_p(x_i) = 1 - \text{abs}((x_i + 0.523) / (0.523)).$$



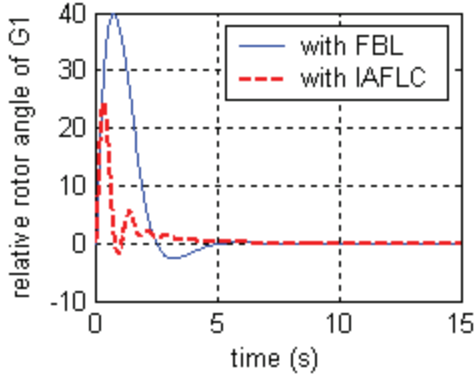
**Fig. 4** – Fuzzy membership functions for  $E'_{qi}$ .

$$u_N(x_i) = 1 - \text{abs}((x_i - 1.5) / 1.5),$$

$$u_z(x_i) = 1 - \text{abs}((x_i) / 1.5),$$

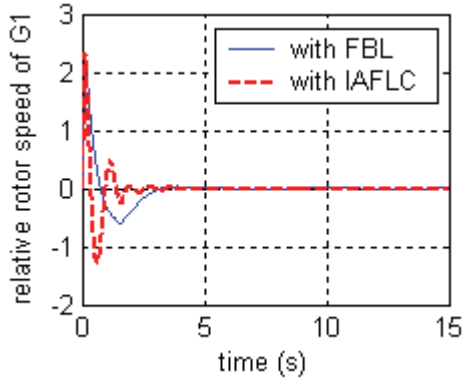
$$u_p(x_i) = 1 - \text{abs}((x_i + 1.5) / 1.5).$$

We use MATLAB program to simulate the overall control system, choosing infinite bus 3 as the reference bus. An indirect adaptive fuzzy control is applied to the system and compared with feedback linearization technique. The results are shown in Figs. 5–13.



**Fig. 5** – Response of the relative rotor angle with FBL and with IAFLC of generator 1.

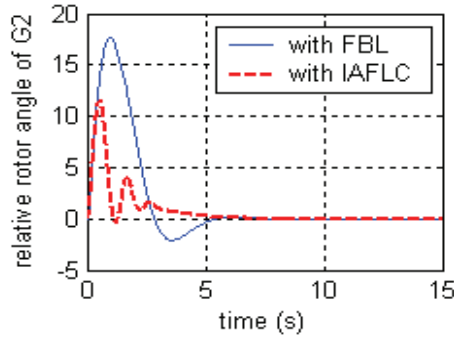
As shown in the simulation results, the system with feedback linearization and with the indirect adaptive fuzzy control the transient stability is improved. Comparing the relative rotor angle ( $\Delta\delta(t)$ ) and the relative rotor speed ( $\omega(t)$ ) of generator 1 and 2, it is clear that the proposed IAFLC gives a better transient results.



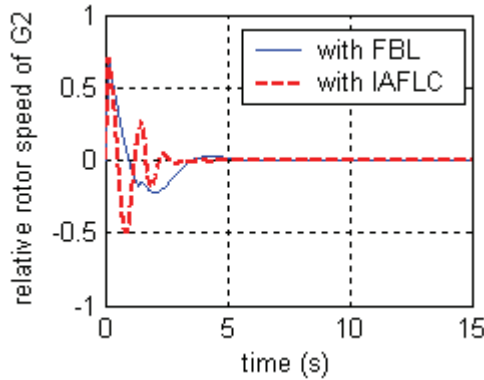
**Fig. 6** – Response of the relative rotor speed ( $\omega(t)$ ) with FBL and with IAFLC of generator 1.

Fig. 6 shows the terminal voltage of generator 1, it is obvious that with FBL the duration of the voltage dip is 5 s and the amplitude of the dip 20%. With the IAFLC both the transient stability and terminal voltage of each

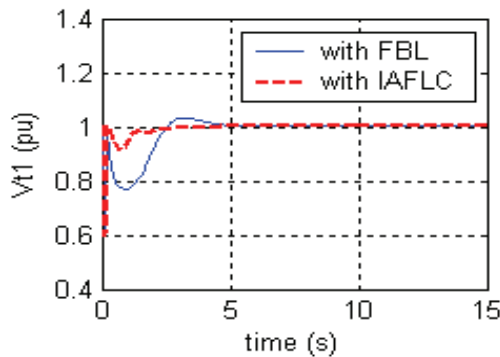
generator are enhanced especially the terminal voltage at generator 1. The duration and amplitude of the voltage dip become 2 s and 4 % respectively.



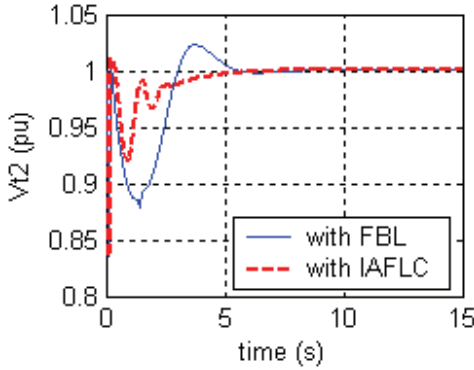
**Fig. 7** – Response of the relative rotor angle with FBL and with IAFLC of generator 2.



**Fig. 8** – Response of the relative rotor speed ( $\omega(t)$ ) with FBL and with IAFLC of generator 2.



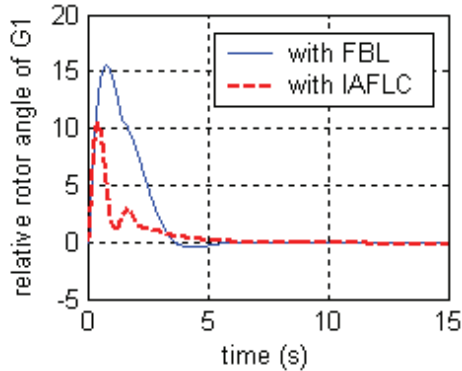
**Fig. 9** – Response of the generator bus terminal voltage ( $V_1(t)$ ) with FBL and with IAFLC.



**Fig. 10** – Response of the generator bus terminal voltage ( $V_2(t)$ ) with FBL and with IAFLC.

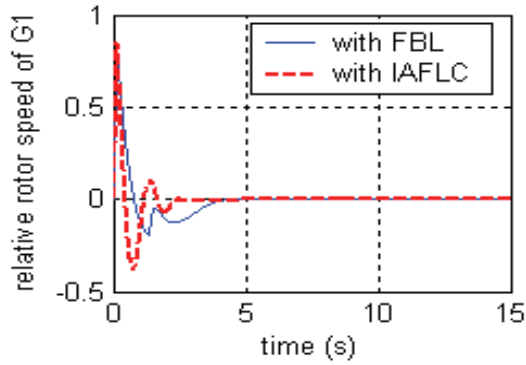
**CASE 2:**

The operating points are the same as in Case 1, while the fault location chosen to be equal to 0.9 ( $\lambda = 0.9$ ). As shown in Fig. 11 and Fig. 13 improvement of the transient stability is registered for both FBL and IAFLC, but in case of IAFLC, the amplitude of oscillations in relative rotor angle ( $\Delta\delta(t)$ ) related to generators 1 and 2 is 30 % less than the FBL controller one. Furthermore, Fig. 12 and Fig. 14 show that the IAFLC system returns to synchronism and stable condition after 2 s, in both generators, however, the FBL controller returns after 4 s.

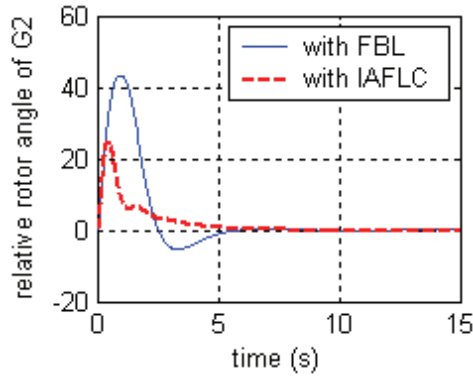


**Fig. 11** – Response of the relative rotor angle with FBL and with IAFLC of generator 1.

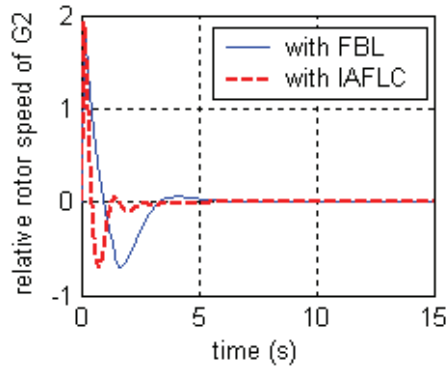
Fig. 16 shows that the terminal voltage of generator 2, where it can see that the duration of the voltage dip and the amplitude of the dip are 5 s and 25 % respectively with FBL, and these values are enhanced and become 3 s and 9 % respectively when the IAFLC is applied.



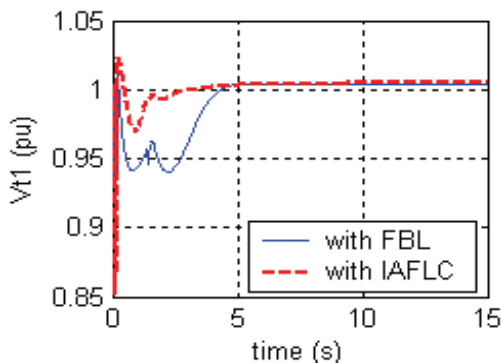
**Fig. 12** – Response of the relative rotor speed ( $\omega(t)$ ) with FBL and with IAFLC of generator 1.



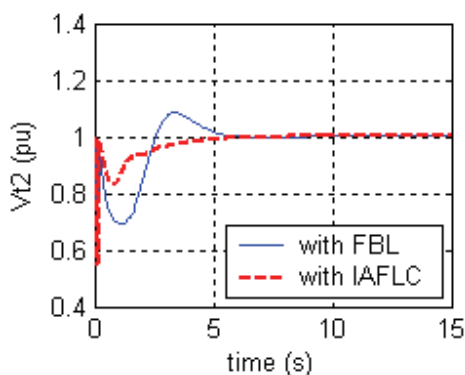
**Fig. 13** – Response of the relative rotor angle with FBL and with IAFLC of generator 1.



**Fig. 14** – Response of the relative rotor speed ( $\omega(t)$ ) with FBL and with IAFLC of generator 1.



**Fig. 15** – Response of the generator bus terminal voltage ( $V_1(t)$ ) with FBL and with IAFLC.



**Fig. 16** – Response of the generator bus terminal voltage ( $V_2(t)$ ) with FBL and with IAFLC.

## 7 Conclusion

This paper presents indirect adaptive fuzzy control scheme for transient stability enhancement of multi-machine power systems. The fuzzy controller is constructed from fuzzy feedback linearization controller whose parameters are adjusted indirectly from the estimates of plant parameters. The adaptation law adjusts the controller parameters on-line so that the plant output tracks the reference model output. The simulation results show that by changing the fault location in cases 1 and 2, the proposed IAFLC control can enhance the transient stability, enrich damping and achieve good post-fault generator terminal voltage.

## 8 List of Symbols

$\delta_i$  – the rotor angle;

$\omega_i$  – the relative rotor speed of the generator;

$P_{ei}$  – the active electric power delivered by the generator  $i$ ;

$P_m$  – the mechanical input power;

$D$  – damping constant;

$M$  – inertia constant;

$E_q$  – the EMF in the quadrature axis;

$E_{fd}$  – the excitation control input.

$B_{ij}$  – the susceptance between node  $i$  and  $j$ ;

$T_{d0}$  – the rotor circuit time constant;

$x_d$  – the direct axis reactance;

$x'_d$  – the direct axis transient reactance;

$x_q$  – the quadrature axis reactance;

$x'_q$  – the quadrature axis transient reactance;

$x_{tr}$  – the transformer reactance;

$x_{L12}$ ,  $x_{L23}$  – reactance of transmission lines;

$\theta_i$ ,  $\theta_{ij}$  – adjustable parameter;

$V_i$  – terminal voltage;

$Q_{ei}$  – the reactive electric power delivered by the generator  $i$ ;

$i_{di}$ ,  $i_{qi}$  – the direct and quadrature axis currents of generator  $i$ ;

$V_{di}$  – the direct axis voltage of generator  $i$ ;

$V_{qi}$  – the quadrature axis voltage of generator  $i$ .

## 9 References

- [1] A.R. Mahran, B.W. Hogg, M.L. El-Sayed: Co-ordinated Control of Synchronous Generator Excitation and Static VAR Compensator, IEEE Transactions on Energy Conversion, Vol. 7, No. 4, Dec. 1992, pp. – 615 – 622.
- [2] Y. Wang, Y.L. Tan, G. Guo: Robust Nonlinear Coordinated Generator Excitation and SVC Control for Power Systems, International Journal of Electrical Power and Energy Systems, Vol. 22, No. 3, March 2000, pp. 187 – 195.
- [3] F.P. Demello, C. Concordia: Concepts of Synchronous Machine Stability as Affected by Excitation Control, IEEE Transactions on Power Apparatus and Systems, Vol. PAS 88, No. 4, April 1969, pp. 316 – 329.

- [4] J.R. Smith, D.A. Pierre, D.A. Rudberg, I. Sadighi, A.P. Johnson, J.F. Hauer: An Enhanced LQ Adaptive VAR Unit Controller for Power System Damping, *IEEE Transactions on Power Systems*, Vol. 4, No. 2, May 1989, pp. 443 – 451.
- [5] P. Kundur, M. Klein, G.J. Rogers, M.S. Zywno: Application of Power System Stabilizers for Enhancement of Overall System Stability, *IEEE Transactions on Power Systems*, Vol. 4, No. 2, May 1989, pp. 614 – 626.
- [6] J.W. Chapman, M.D. Ilic, C.A. King, L. Eng, H. Kaufman: Stabilizing a Multimachine Power System via Decentralized Feedback Linearizing Excitation Control, *Transactions on Power Systems*, Vol. 8, No. 3, Aug. 1993, pp. 830 – 839.
- [7] F.K. Mak: Design of Nonlinear Generator Exciters using Differential Geometric Control Theories, *IEEE Conference on Decision and Control*, Tucson, AZ, USA, Vol. 1, Dec. 1992, pp. 1149 – 1153.
- [8] Y. Guo, D.J. Hill: Nonlinear Decentralized Control of Large-scale Power Systems, *Automatica*, Vol. 36, No. 9, Sept. 2000, pp. 1275 – 1289.
- [9] S. Jain, F. Khorrarni, B Fardanesh: Adaptive Nonlinear Excitation Control of Power Systems with Unknown Interconnections, *IEEE Transaction on Control System Technology*, Vol. 2, No. 4, Dec. 1994 , pp. 436 – 446.
- [10] L.X. Wang: *Adaptive Fuzzy System and Control: Design and Stability Analysis*, Prentice Hall, NJ, 1994.
- [11] S. Tong, J.T. Tang, T. Wang: Fuzzy Adaptive Control of Multivariable Nonlinear Systems, *Fuzzy Set and Systems*, Vol. 111, No. 2, April 2000, pp. 153 – 167.
- [12] M. Kadjoudj, N. Golea, M. El Hachemi Benbouzid: Fuzzy Rule-based Model Reference Adaptive Control for PMSM Drives, *Serbian Journal of Electrical Engineering*, Vol. 4, No. 1, June 2007, pp. 13 – 22.
- [13] B. Allaoua, A. Abderrahmani, B. Gasbaoui, A. Nasri: The Efficiency of Particle Swarm Optimization Applied on Fuzzy Logic DC Motor Speed Control, *Serbian Journal of Electrical Engineering*, Vol. 5, No. 2, Nov. 2008, pp. 247 – 262.
- [14] M.N. Lakhoua: Using Fuzzy Logic for Automatic Control Case Study of a Problem of Cereals Samples Classification, *Serbian Journal of Electrical Engineering*, Vol. 6, No. 2, Nov. 2009, pp. 203 – 214.