

## Simulation of Closed Loop Controlled Boost Converter for Solar Installation

Athimulam Kalirasu<sup>1</sup>, Subharensu Sekar Dash<sup>2</sup>

**Abstract:** With the shortage of the energy and ever increasing of the oil price, research on the renewable and green energy sources, especially the solar arrays and the fuel cells, becomes more and more important. How to achieve high step-up and high efficiency DC/DC converters is the major consideration in the renewable power applications due to the low voltage of PV arrays and fuel cells. In this paper digital simulation of closed loop controlled boost converter for solar installation is presented. Circuit models for open loop and closed loop controlled systems are developed using the blocks of simulink. The simulation results are compared with the theoretical results. This converter has advantages like improved power factor, fast response and reduced hardware.

**Keywords:** Boost converter, Solar cells, PV cells, Matlab, Simulation.

### 1 Introduction

The massy usage of the fossil fuels, such as the oil, the coal and the gas, result in serious greenhouse effect and pollute the atmosphere, which has great effect on the world. Meanwhile, there is a big contradiction between the fossil fuels supply and the global energy demand, which leads to a high oil price in the international market recently. The energy shortage and the atmosphere pollution have been the major limitations for the human development. How to find renewable energy is becoming more and more exigent.

Photovoltaic (PV) sources are one of the significant players in the world's energy portfolio and will become the biggest contributions to the electricity generation among all renewable energy candidates by year 2040 because it is truly a clean, emission-free renewable electrical generation technology with high reliability. The task of a maximum power point tracker (MPPT) in a photovoltaic (PV) energy conversion system is to continuously tune the system so that it draws maximum power from the solar array regardless of weather or load conditions. Since the solar array has a non ideal voltage – current characteristic and the conditions such as insolation, ambient temperature, and wind that affect the output of the solar array are unpredictable, the tracker must contend with a nonlinear and time-varying system. Many tracking algorithms

---

<sup>1</sup>Satyabhama University, Chennai, India; E-mail: akalirasu@yahoo.co.in

<sup>2</sup>SRM University, Chennai, India; E-mail: munu\_dash2k@yahoo.com

and techniques have been developed. The perturbed and observed method [1] and the Incremental Conductance method [2], as well as variants of those techniques [3, 4] are the most widely used. The perturbed and Observe method is known for its simple implementation, but it deviates from and observe method oscillates close to a maximum power point (MPP) in the atmospheric conditions are constant or slowly changed. However when weather rapidly changes the perturb and observe method fails to track the maximum power point effectively [4, 5].

Other methods for solar array MPP tracking include short circuit current [7] and the open circuit voltage of the PV module techniques [5, 8]. The MPP tracking method using the short circuit current of the PV module exploits the fact that the operating current at the MPP of the solar array is linearly proportional to its short circuit current [7]. Thus, under rapidly changing atmospheric conditions. This method has a relatively fast response time for tracking the MPP. However, the control circuit is still somewhat complicated and both the conduction loss and the cost of the MPPT converter are still relatively high [5]. Furthermore, the assumption that the operating current at the MPP of the PV module is linearly proportional to the short circuit current of the PV module is only an approximation. In reality, the application of this technique always results in PV module operation below the maximum power point.

Open circuit voltage of the PV module [5, 8] employs the fact that the open circuit voltage of the solar array at the MPP is linearly proportional to its open circuit voltage [8]. This technique has some limitations and disadvantages as the short circuit current of PV module method described above. Although the method is cost efficient, its application results in considerable errors in MPP tracking and consequent energy losses. Additionally, both the open circuit voltage and the short circuit current of PV module techniques fail to track the MPP effectively if solar array cells are partially shaded or if some cells in the array are damaged.

The limitations of the conventional boost converters are analyzed and the conceptual solution for high step-up conversion is proposed in this paper. Then the state-of-the-art topologies are covered and classified based on the circuit performance. The challenges in high step-up renewable energy applications are summarized to generate the next generation non-isolated high step-up DC/DC converters.

## 2 PV Cell System

The density of power radiated from the sun at the outer atmosphere is  $1.373 \text{ kW/m}^2$ . Final incident sun light on the earth surface has the peak density of  $1 \text{ kW/m}^2$  at noon in the tropics. Solar cell can convert the energy of sunlight

directly in to electricity. A simplified equivalent circuit of a solar cell consists of a current source in parallel with a diode variable resistor is connected to the solar cell generator as a load. Relationship between the current and voltage may be determined from the diode characteristics equation:

$$I = I_{ph} - I_0 \left( e^{qv/kT} - 1 \right) = I_{ph} - I_d . \quad (1)$$

Where  $q$  is the electron charge,  $k$  is the Boltzmann constant,  $I_{ph}$  is the photocurrent,  $I_0$  is the reverse saturation current,  $I_d$  is the diode current and  $T$  is the solar cell operating temperature (K).

The stand-alone photo-voltaic energy system requires storage to meet the energy demand during period of low solar irradiation and night time. Battery storage in a solar system should be properly controlled to avoid catastrophic operating condition like over charging or frequent deep discharging. Storage batteries account for the most PV system failures and contribute significantly to both initial and the eventual replacement cost. Charge controllers regulate the charge transfer and prevent the battery from being excessively charged and discharged. Switch mode DC to DC converters are used to match the output of a PV generator to a variable load. DC to DC converters allow the charge current to be reduced continuously in such a way that the resulting battery voltage is maintained at a specified value. A practical photovoltaic energy conversion system block diagram is shown in Fig. 1.

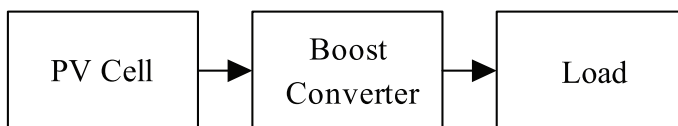

Fig. 1 – Block Diagram.

### 3 Simulation Results

Simulation is done using Matlab and the results are presented. Boost converter for solar installation system is shown in Fig. 2a, DC input voltage is shown in Fig. 2b. Driving pulses of the MOSFET are shown in Fig. 2c. Voltage across the MOSFET is shown in Fig. 2d and output current is shown in Fig. 2e. DC output voltage is shown in Fig. 2f. Variation of output voltage with the input voltage is shown in Fig. 2g. Data used for simulation studies is as follows:

## Simulation of Closed Loop Controlled Boost Converter for Solar Installation

Input Voltage: 15 V

Output Voltage: 50 V

$L_F$ : 1  $\mu$ H

$C_F$ : 2000  $\mu$ F

$R_L$ : 200  $\Omega$

$T_{ON}$ : 0.325 ms

$T_{OFF}$ : 0.175 ms

Open loop system with a disturbance at the input is shown in Fig. 3a. A step rise in input voltage is applied at  $t = 2.5$ s as shown in Fig. 3b. Output voltage also increases as shown in the Fig. 3b. Closed loop system is shown in Fig. 4a. Output voltage is sensed and it is compared with a reference voltage. The error is processed by a PI controller, output of PI controller adjusts the pulse width to maintain the output voltage constant, input voltage and output voltage of closed loop system is shown in Fig. 4b, output voltage reduces and reaches the set value. The following equation used in PI controller is:

$$V_0 = k_p e + k_i \int e dt . \quad (2)$$

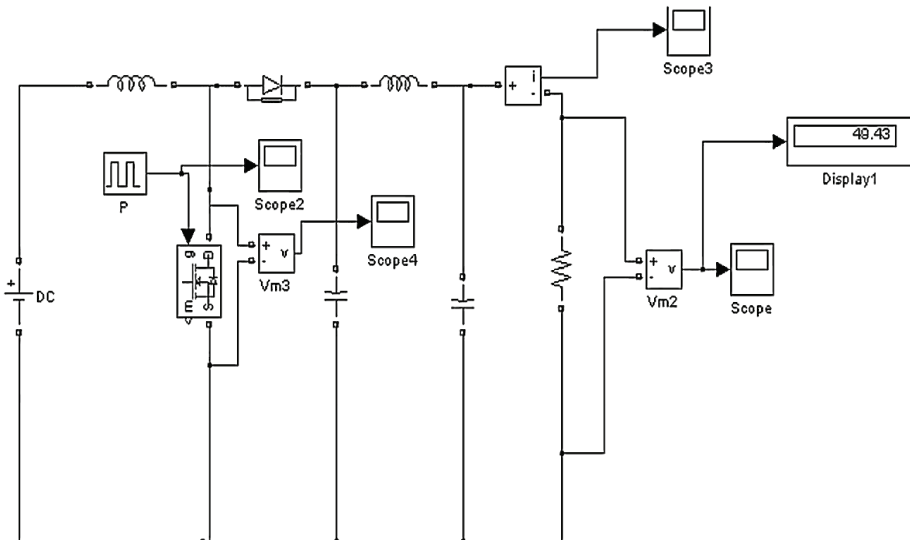

**Fig. 2a** – Simulink circuit of solar installation system.

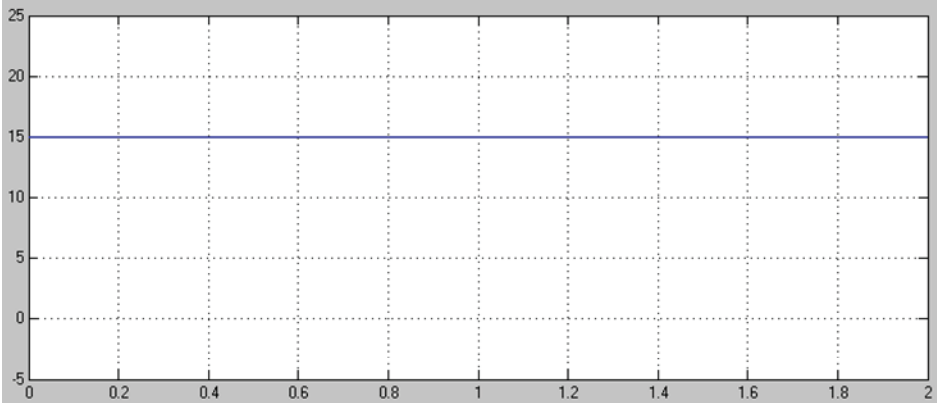

Fig. 2b – Input voltage.

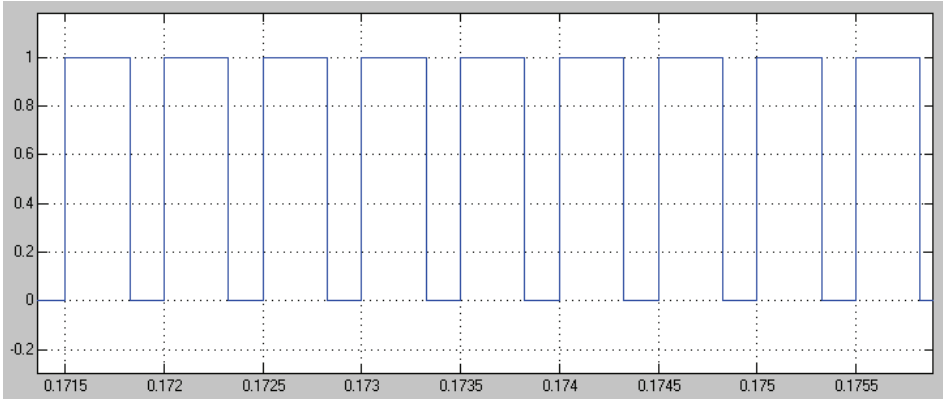

Fig. 2c – Driving pulses.

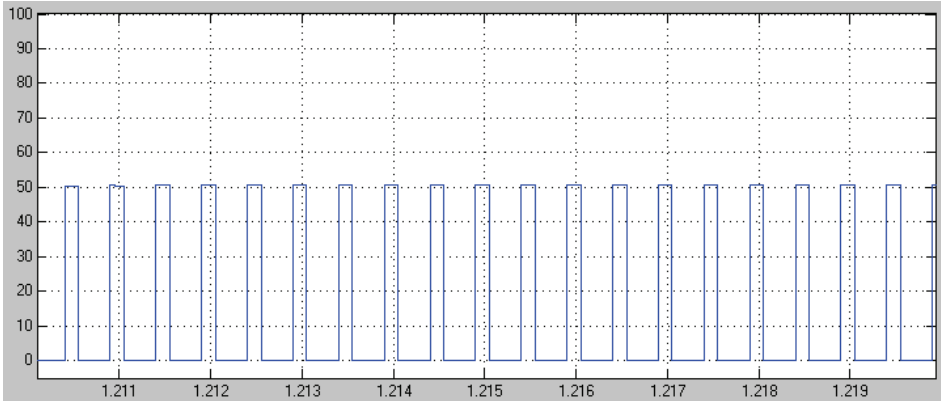
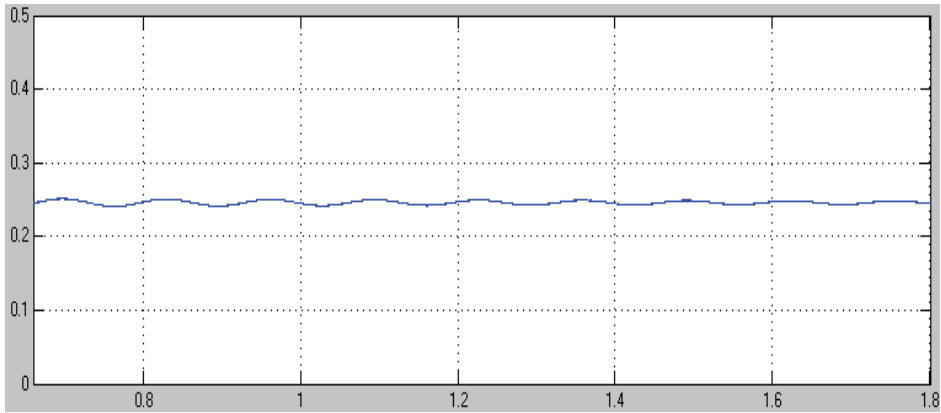
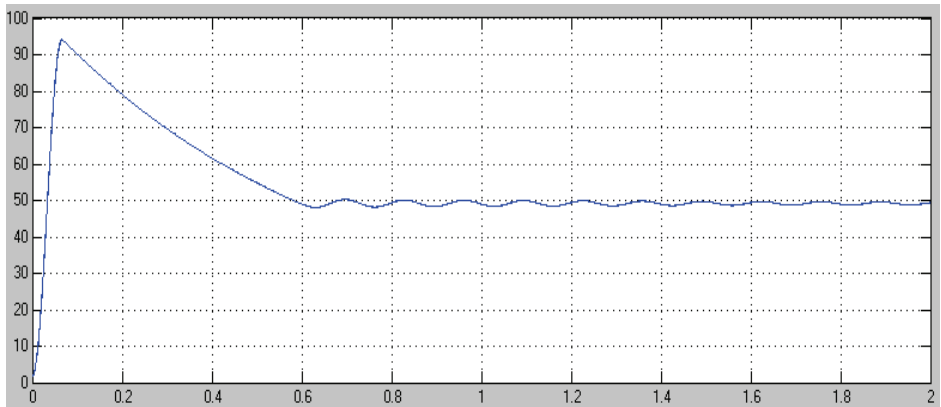

Fig. 2d – Voltage across switch.

# Simulation of Closed Loop Controlled Boost Converter for Solar Installation



**Fig. 2e** – *Output current.*



**Fig. 2f** – *DC Output voltage.*

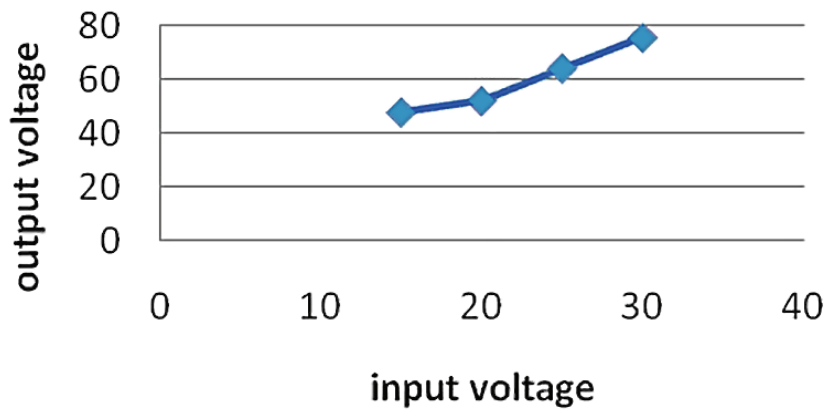

**Fig. 2g** – *Input vs. Output.*

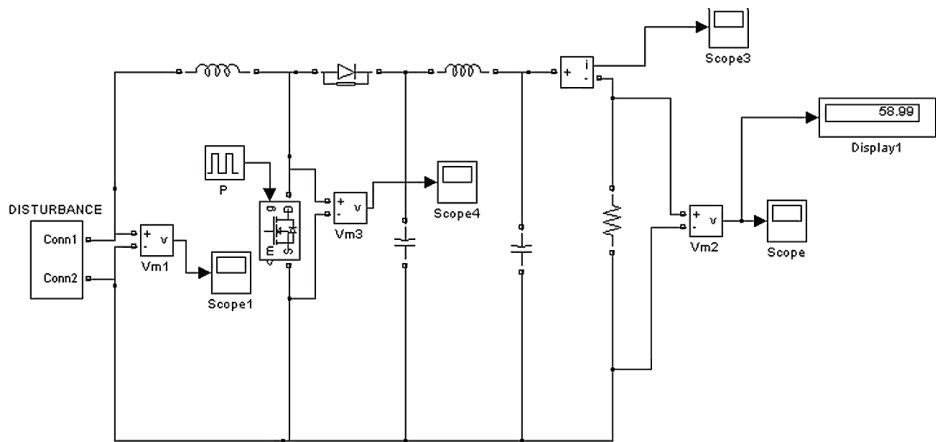

Fig. 3a – Open loop system with a disturbance at the input.

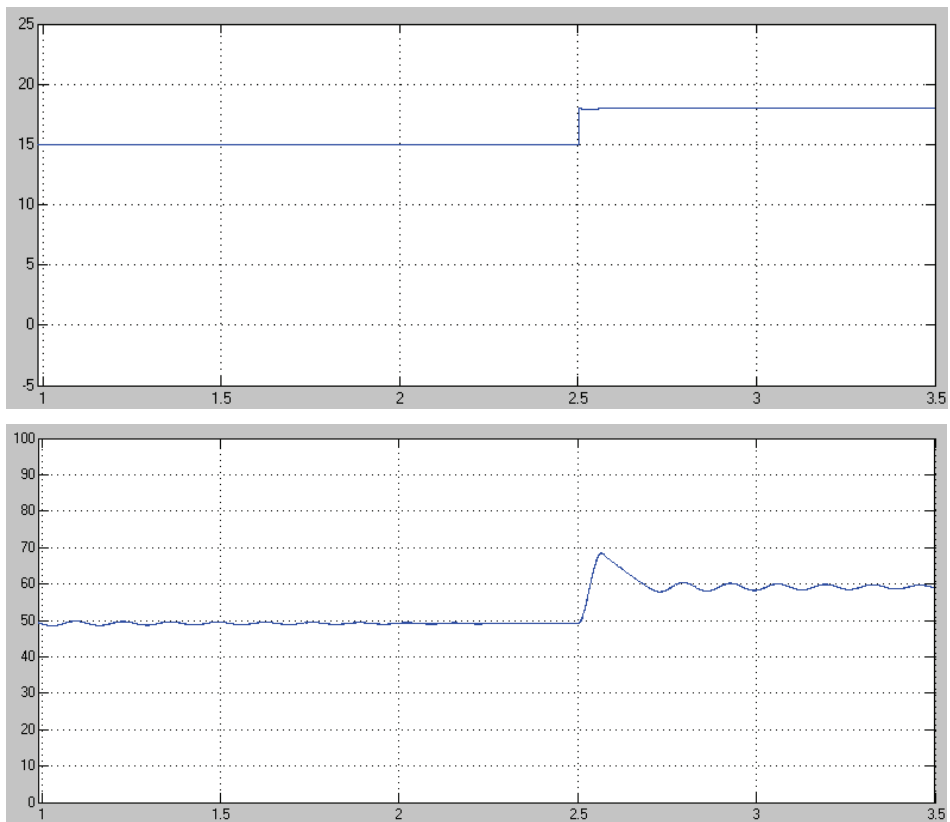
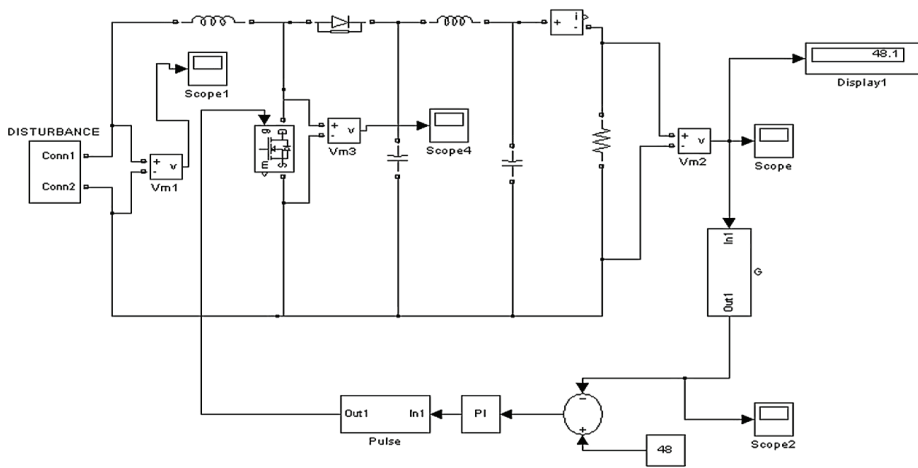
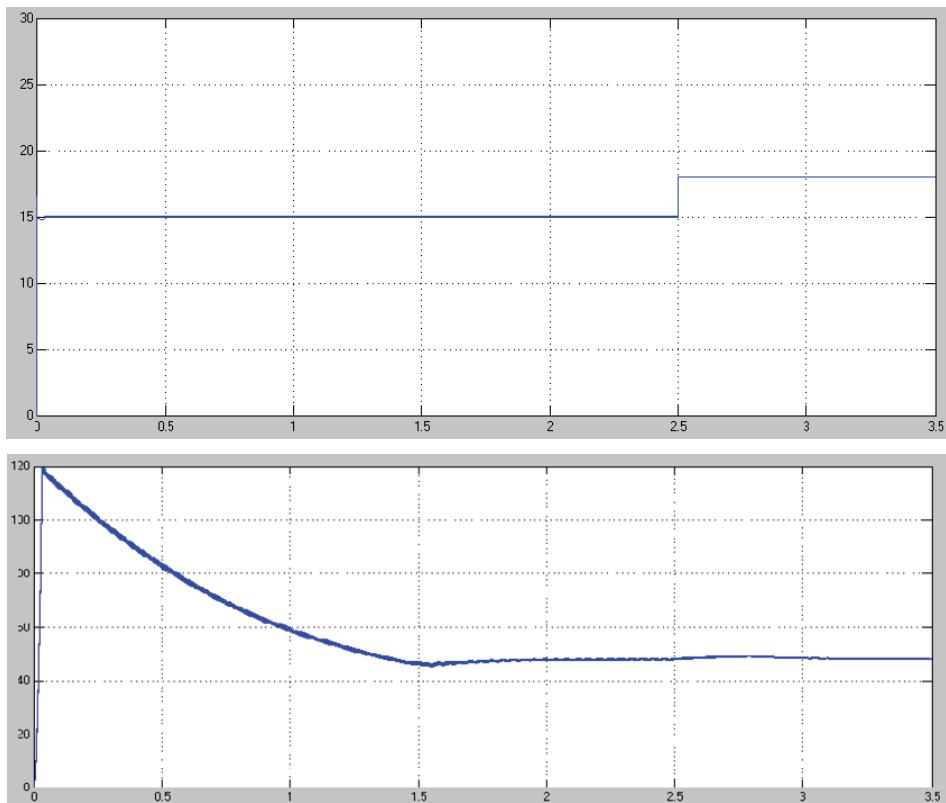

Fig. 3b – Input and output voltages.

## Simulation of Closed Loop Controlled Boost Converter for Solar Installation



**Fig. 4a** – Simulink model of Closed loop system.



**Fig. 4b** – Input and output voltages.



## **4 Conclusion**

This paper presents simulation of open loop and closed loop controlled boost converter system for solar installation system. Matlab models for open loop and closed loop systems are developed using the blocks of simulink and the same are used for simulation studies. The closed loop system is able to maintain constant voltage. This converter has advantages like reduced hardware and good output voltage regulation. Thus the boost converter is capable of improving the voltage level from 15 V to the required level.

## **5 References**

- [1] O. Wanyezuck: Dynamic Behaviour of a Class of Photovoltaic Power Systems, IEEE Transaction on Power Apparatus and Systems, Vol. PAS-102, No. 9, Sept.1983, pp. 3031 – 3037.
- [2] K.H. Hussern, I. Muta, T. Hoshino, M. Osakada: Maximum Photovoltaic Power Tracking: An Algorithm for Rapidly Changing Atmospheric Conditions, IEE Proceedings – Generation, Transmission and Distribution, Vol.142, No.1, Jan.1995, pp.59 – 64.
- [3] M. Calais, H. Hinz: A Ripple based Maximum Power Point Tracking Algorithm for a Single Phase Grid Connected Photovoltaic System, Solar Energy, Vol. 63, No.5, Nov. 1998, pp. 277 – 282.
- [4] Y.C. Kuo, T.J. Liang, J.F. Chen: Novel Maximum Power Point Tracking Controller for Photovoltaic Energy Conversion System, IEEE Transaction on Industrial Electronics, Vol. 48, No. 3, June 2001, pp. 594 – 601.
- [5] D.Y. Lee, H.J. Loh, D.S. Hyun, I. Choy: An Improved MPPT Converter using Current Compensation Method for Small Scaled PV-applications, Applied Power Electronics Conference (APEC'03), Vol.1, Feb. 2003, pp. 540 – 545.
- [6] E. Koutroulis, K. Kalaitzakis, N.C. Voulgaris: Development of a Microcontroller based Photovoltaic Maximum Power Point Tracking Control System, IEEE Transaction on Power Electronics, Vol. 16, No. 1, Jan. 2001, pp. 46 – 54.
- [7] T. Noguchi, S. Dogashi, R. Nakamoto: Short Current Pulse based Maximum Power Point Tracking Method for Multiple Photovoltaic and Converter Module System, IEEE Transaction on Industrial Electronics, Vol. 49, No.1, Feb. 2002, pp. 217 – 223.
- [8] J.H.R. Enslin, M.S. Wolf, D.B. Snyman, W. Swiegers: Integrated Photovoltaic Maximum Power Point Tacking Converter, IEEE Transaction on Industrial Electronics, Vol. 44, No. 6, Dec. 1997, pp. 769 –773.
- [9] C.T.Chen, Introduction for Linear System Theory, Oxford University Press, New York, 1999.
- [10] R.D. Middlebrook, S. Cuk: A General Unified Approach to Modeling Switching Converter Power Stages, International Journal of Electronics, Vol. 42, No. 6, June 1977, pp. 521 – 550.
- [11] E.V. Solodonovik: An Analytical Approach to the Design of Nonlinear Time Varying Control System, International Journal of Systems Science, Vol. 32, No. 5, May 2001, pp. 629 – 637.
- [12] A.R. Gaidauk: Analytical Control Synthesis for Nonlinear Objects of Certain Class, Automation and Remote Control, Vol 2, 1993, pp. 64 – 76, (in Russian).
- [13] A.R. Gaidauk, E.V. Solodonovik: Control Design based on Nonlinear Dynamic Feedback, Conference on New Directions in Feedback Systems, Ufa, Russia,1993, (in Russian).

## Simulation of Closed Loop Controlled Boost Converter for Solar Installation

- [14] M. Vidyasagar: Nonlinear System Analysis, Prentice – Hall, Englewood Cliffs, NJ, 1993.
- [15] V. Matrosov: Vector Lyapunov Functions Method in Stability Theory, Nauka, Moscow, Russia, 1987.
- [16] M. Buresch: Photovoltaic Energy System: Design and Installation, McGraw-Hill, New York, 1983.
- [17] S.R. Wenham, M.A. Green, M.E. Watt: Applied Photovoltaic, Earthscan, UK, 2007.
- [18] E. Solodovnik, G. Cokkinidies, A.P.S. Meliopoulos, Utilisation of Automatic Differentiation in VTB Simulation Environment, 33<sup>rd</sup> Annual Simulation Symposium, Washington, Apr. 2000, pp. 59 – 63.