

Power System Reliability Enhancement by Using PowerformersTM

Rahmat-Allah Hooshmand¹,
Majid Moazzami¹, Ali Akbar Nasiri

Abstract: A high-voltage generator powerformerTM is a new generation of the AC generators. The most significant advantages of these powerformersTM are their direct connection to high-voltage grid, higher availability, and more reactive power margin, short term overloading capacity and removing the power transformer from the structure of the power plant. In this paper, the installation effect of these generators on the power system reliability is investigated. The amount of the effects depends on the type and location of the power plant, location of the powerformerTM, the size of load and network topology. For this purpose, in the 6-bus IEEE RBTS system, the conventional generators are replaced by these new powerformersTM and then, the reliability indices are evaluated. The simulation results show that the reliability indices such as the expected duration of load curtailment (EDLC) and the expected energy not served (EENS) are improved.

Keywords: Power Systems Reliability, PowerformerTM, Expected Duration of Load Curtailment (EDLC), Expected Energy Not Served (EENS).

1 Introduction

Systems reliability depends largely on economical problems requiring more investment to achieve better reliability. At present, the only approach to improve the equipment reliability without adding a new capacity is either through time reduction by hiring more personnel for repairs, or increasing in-service time (up time) through more sophisticated monitoring and maintenance techniques[1-3]. These alternatives are now in common practice since the combination of capital scarcity, uncertainties in demand and fuel costs is higher for new equipment.

In recent years, many research activities on power system reliability evaluation have been done. In all the studies, several policies have been suggested for the reliability improvement of power systems. In this regard, in this paper the performance of a new generator under powerformerTM on power

¹Department of Elec. Eng., University of Isfahan, Hezar-Jerib St., P. Code: 174673441, Isfahan, Iran;
E-mails: hooshmand_r@eng.ui.ac.ir, m_moazzami79@yahoo.com, nasiri.83@gmail.com

system reliability is evaluated. In [4], the structure of powerformersTM as the main step in power plant engineering is described. A mathematical model of the operation characteristics for powerformerTM is introduced in [5]. In this paper by using electromagnetic field equation and external circuit of a generator, operation curves for powerformerTM under different conditions of short circuit characteristic, open circuit characteristic, regulation characteristics and external characteristic are calculated.

In [6], the effects of the electricity system requirements on design and also optimal application of powerformerTM are explained. Also, reference [7] illustrates the XLPE cables applied in powerformerTM. In other references, some problems such as cost/benefit analysis of generation investment considering system constraints in the presence of powerformerTM [8-9], and the impact of powerformersTM on large-scale transmission system voltage stability with powerformersTM are investigated [10]. Since the generators have limited application background, not many researches are involved in the analysis of the effects of generators over the reliability of power systems.

A study has been performed on the evaluation of powerformersTM by SECRC/ABB institution for the estimation of their reliability and indices [11]. In [12], the reliability of the power systems and powerformersTM based on composite reliability is presented through state enumeration. In this reference, composite power system reliability and powerformersTM are offered without a few sample buses.

In this paper, the installation effect of powerformersTM on power plants is investigated for the evaluation of the reliability of the power systems. For the evaluation of reliability indices, cut and path sets theory [1, 18] was used. Then, by replacing this type of power plant, the location of installation, the number of these generators and the changes in reliability indices are studied. Finally, after some tests, a number of reliability indices for the installation and replacement of powerformersTM are determined. The results of this replacement are compared with a conventional generator. This comparison shows that the use of a powerformerTM increases the system reliability indices.

2 A Brief Introduction to PowerformersTM

This new type of generators was introduced under the title of powerformersTM by ABB factory in Sweden in 1998. Unlike conventional electric generators that have voltage terminal up to only 30kV, they are able to act without the use of MV switchgear and a step-up transformer. With the existing technology, the range of this voltage level might even go up to 400kV. Fig. 1 shows the arrangement of powerformersTM. As it can be seen in this figure, the powerformerTM is connected to the electricity transmission system

without a step-up transformer and a generator circuit-breaker. In other words, the only element in this arrangement is the high-voltage circuit-breaker.

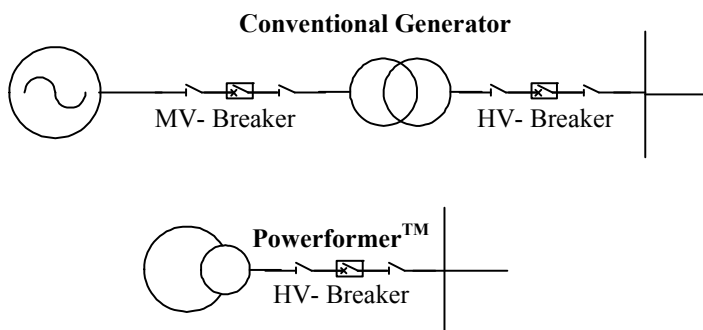

Fig. 1 – Line comparison of a conventional generator with a powerformer™.

A power plant with a powerformer™ is about 10 to 15 percent more efficient than a similar power plant with a conventional generator and a step-up transformer. Because a normal step-up transformer has reactive losses within in the range of 10-15 percent of its capacity, therefore by removing the step-up transformer, it can deliver 10-15% more reactive power to the network with the same power factor.

In powerformers™, due to a lower current in the stator windings resulting in less power losses at a given input active power, the power plant can generate more power. As a result, the economic indices of the plant are increased. Also, due to the removal of the step-up transformer from the situation where the powerformer™ is used, the values of the short circuit current is reduced. Furthermore, the three-phase fault is very severe in the conventional generator, while in the powerformers™ the fault of occurrence probability of three-phase and the phase to phase faults is reduced because of the high reliability of the XLPE cables used in generator stator windings. In addition, the equipment used in the structure of the powerformers™ is under less field stress compared with the conventional generators. All of these advantages lead to the reliability improvement of the power system.

The concept of powerformers™ implies low current and large thermal mass in the stator. This means that the powerformers™ have greater thermal overload potential for a longer period of time in their stator windings than conventional generators. This means that they may provide more reactive support for an extended period of time compared with the conventional generator.

The installation of powerformers™ and removal of the step-up transformers, lead to the improvement of the transient stability limit. In a multi-machine power system, the effect of powerformers™ on the system stability

should be evaluated. In this case the transient stability limit depends on the network topology and the location of generators and its parameters.

3 Powerformer™ Reliability Parameters

Since the powerformer™ is a recent innovation, its reliability evaluation in the long run is only possible through the available data obtained from power cables and some experiments performed by the manufacturers.

A. Stator winding reliability

The reliability evaluation and failure rate of stator winding can be performed by using the failure data obtained from old and conventional three-phase cables that were installed in the distribution and transmission systems during 10 to 30 years ago. Based on the information in reference [11], failure rate for the stator and the related joints are as follows:

$$\text{Failure Rate for Stator} = 0.02 \frac{\text{faults}}{(100 \text{ three phase circuit} - \text{km} - \text{years})},$$

$$\text{Failure Rate for Joint} = 0.05 \frac{\text{faults}}{(100 \text{ joint} - \text{years})}.$$

The calculated failure rate for high-voltage stator winding is also equal to 0.53 faults/(100 generator-years). So the amount of mean time to failure (MTTF) is calculated as follows:

$$\lambda_{\text{stator}} = 0.0053 \frac{\text{faults}}{\text{years}},$$

$$\text{MTTF} = \frac{1}{0.0053} = 190 \text{ years}.$$

In case the fault is inside the stator core and a severe fault occurs, the stator laminations should be completely replaced. In this situation, the mean time to repair (MTTR) is estimated to be about 13 days. Also, the unavailability of the high-voltage stator winding in these generators is as low as 0.019%. Thus, according to the evaluations performed, it can be concluded that the powerformer™ failure rate is significantly lower than the recorded failure rate at the conventional generator of hydro power plants.

B. Step-up transformer and substation equipment

Electric substations are the main source of failures and faults in power systems. Failures of station equipment, such as circuit-breakers, transformers and buses have significant effect on the power system reliability. So the system can be made more reliable by removing some of the components that can fail,

such as the transformer and the circuit-breakers. This can be done by powerformers™.

C. Rotor reliability

There is no difference between rotor of powerformers™ and conventional generators. So, all of the various exciter systems in conventional generators can be used in powerformers™. Thus, it is reasonable to suppose that the failure rates of conventional rotors and the rotors in powerformers™ are equal. **Table 1** shows the forced outage rate (FOR) for different power plants in two generators used in this study (conventional generators and powerformers™).

Table 1
Forced outage rates of conventional generators and powerformer™.

Power Plant Machine	Hydro Unit 2×50MW in bus 1	Thermal Unit 1×100MW in bus 2
Conventional Generator	0.025	0.05
Powerformer™	0.004	0.02

4 Evaluation Method of the System Reliability with Powerformers™

Basic reliability indices for power systems reliability evaluation with powerformers™, are frequency and mean time to failure of load. These indices are categorized and based on the system and load point indices. System indices covered a large area of the system operating situations. In this paper, the expected energy not served (EENS) is the main index for the comparison of different evaluation methods.

A. Flowchart and methodology

The calculation method of the reliability parameters for simulation is based on the minimal cut and path sets [1,18]. Some terminologies are used in this method, which are introduced as follows:

Path: A forward way from one node to other nodes.

Minimal path: A path, which is started from a source node and is ended to a load node so that it does not cross another node more than once and does not produce any loop.

Basic minimal path: A minimal path in which each element is only connected to the previous or next element in the path.

Cutset: A set of branches in which if one branch is cut, it causes the disconnection of the path between the source node and the sink node.

Minimal cutset: A set of the system elements in which if all of them are failed together, the overall system is failed. However, if only one of them is not failed, the overall system works correctly.

Tree: A path that starts from the source node and ends at the sink node so that it contains all the system elements and does not create any loop.

Failure rate (λ_i): The number of failures or outages of the i -th element in a year.

Repair time (r_i): The outage time duration (in hour) of the i -th element.

Unavailability (U_i): The amount of unavailability of the i -th element (hour per year – hr/yr).

The computation of the reliability algorithm has four stages as follows:

- 1) Creation of the system graph model.
- 2) Determining the system paths and minimizing them.
- 3) Extraction of minimal cutsets.
- 4) Calculation of the reliability indices.

In the following, these four stages are explained.

1) Creation of the graph model of the system

For modeling the system, at first, the sources are represented by a star (\star). The Lines, transformer, breaker, disconnectors, load, and bus are also modeled by a node (\circ). The connection points are indicated by (\circ) and the number of the output lines of the node are shown by the numbers outside (\circ). The load node is represented by a black circle (\bullet). The normally open and close breakers have labels by NO and NC respectively.

2) Determining the system paths and minimizing them

In order to find the path sets, the following steps are taken:

- Step 1. Determining the tree
- Step 2. Creating the paths
- Step 3. Minimizing the paths

Step 1. Determining the Tree

In the system graph, each tree starts from a source node and ends with a sink node. It should be noted that the repetition of the branches is not permitted and the components of the path should not create any loop. This procedure is illustrated by a simple example.

In the following graph (Fig. 2), node 5 is a source node and node 1 is a sink node. Also, in Fig. 3, a tree structure is formed for sink node 1, based on the connection of the components the graph in Fig. 2.

Step 2. Creating the paths

Once the tree is formed and completed, the paths can be found easily. All of the paths are:

- 1-2-3-4-3-2-...
- 1-2-3-4-5
- 1-2-5
- 1-4-3-2-3-4-...
- 1-4-3-2-5
- 1-4-3-5
- 1-4-5

Paths 1-2-3-4-3-2-... and 1-4-3-2-3-4-... are not minimal, because of the recurrence of node 3 in the loop.

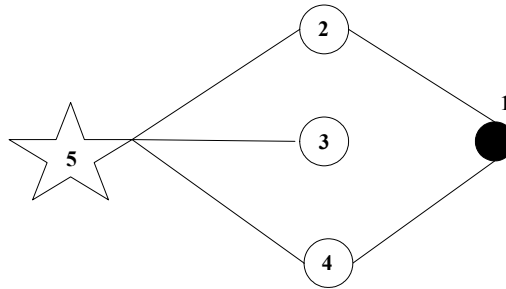

Fig. 2 – Graph for determining the tree paths.

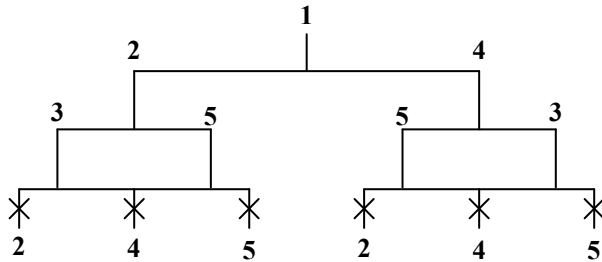

Fig. 3 – Tree structure of graph system for sink node (Node 1).

Step 3. Minimizing the paths

After eliminating the non-minimal paths, the basic paths are:

- 1-4-5,
- 1-2-5

The following paths are also eliminated, because the basic paths are their subsets them:

- 1-4-3-5,
- 1-4-3-2-5,
- 1-2-3-4-5

Now, the minimal cut-sets are extracted from the basic paths.

3) Extraction of minimal cut-sets

For determining the minimal cut-sets, the following terms are defined:

Passive Failure: It is occurred when a component is failed. However, the failure of this element does not have any effect on the performance of other elements.

Active Failure: It occurs when a component fails and its failure has some effects on the performance of other elements.

4) Extraction first order passive failure cut-sets

In order to explain how the first order passive failure cut-sets is extracted, consider a sample system entitled RBTS power system shown in Fig. 4. Graph model of Fig. 4 is illustrated in Fig. 5. Regarding this graph, the basic paths are:

- Basic path 1: 1-2-5-9-13-15-17-18;
- Basic path 2: 1-2-5-8-12-10-7-11-14-16-17-18;
- Basic path 3: 3-4-7-11-14-16-17-18;
- Basic path 4: 3-4-7-10-12-8-5-9-13-15-17-18.

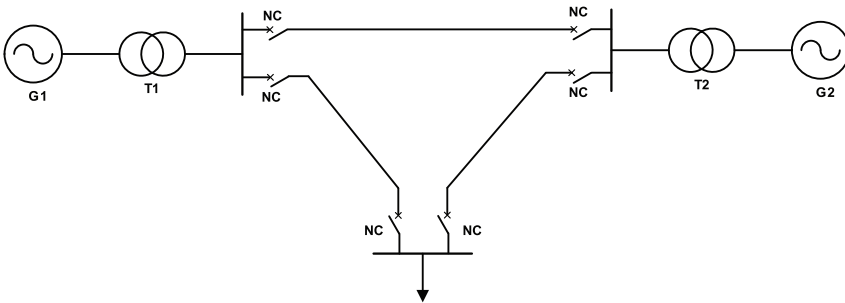

Fig. 4 – A Sample system entitled RBTS power system.

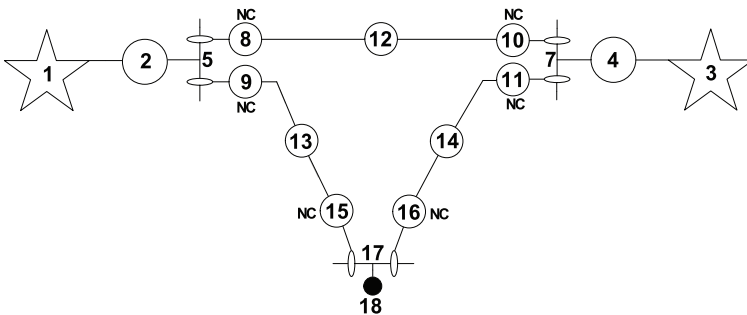

Fig. 5 – Graph of the system related to Fig. 4.

In all the paths, each time that one node appears, one number is counted. Since the number of appeared nodes in the paths is equal to the number of the basic paths, these are then passive cut-sets with the first order. For this example, Nodes 17 and 18 are the first order passive cut-sets.

5) Extraction first order active failure cut-sets

In order to explain the deduction of active first order failure cut-sets, graph Fig. 5 is used. At first, one sink node and its associated path are taken into consideration. Then other nodes in that path are found. Now, each of these nodes should be examined to see if the node is not a passive first order cut-set or is not a fictitious node or not a normally open node, or is not a sink node. If one or several nodes disconnect the path between the sink node and source node; those nodes are the first order active cut-sets.

Performed on the graph in Fig. 5 the basic paths are:

- Path 1: 1-2-5-9-13-15-17-18
- Path 2: 1-2-5-8-12-10-7-11-14-16-17-18
- Path 3: 3-4-7-11-14-16-17-18
- Path 4: 3-4-7-10-12-8-5-9-13-15-17-18

Now, consider Node 18. For other nodes in Path 1, the above-mentioned conditions are examined. Node 15 meets all requirements. This node is located in both Paths 1 and 4. Also, Node 15 is in the path of load 18 and also in two minimal paths. Regarding this, when a failure occurs in Node 15, the differential protective device operates and opens Node 16. This operation leads to the disconnection of all the paths connected to the sink. Therefore, failure in Node 15 is an active first order one. The other first order cut-set is 16.

B. Calculation of the reliability indices

The reliability indices are calculated by approximated methods and series and parallel formulas for cut-sets. If the *k*-th minimal path has *m* parallel elements, then the indices of the equivalent element for this path are *r_p*, *U_p* and *λ_p* calculated as follows:

$$\frac{1}{r_p} = \frac{1}{r_1} + \frac{1}{r_2} + \frac{1}{r_3} + \dots + \frac{1}{r_m}, \tag{1}$$

$$U_p = (\lambda_1 \cdot \lambda_2 \cdot \dots \cdot \lambda_m) \cdot (r_1 \cdot r_2 \cdot \dots \cdot r_m), \tag{2}$$

$$\lambda_p = \frac{U_p}{r_p}. \tag{3}$$

Now, the equivalent paths are in series. After calculating the equivalent indices of all paths, the final values of reliability indices are computed as:

$$\lambda_{total} = \sum_{k=1}^n \lambda_{pk} , \quad (4)$$

$$U_{total} = \sum_{k=1}^n U_{pk} = EDLC , \quad (5)$$

$$r_{total} = \frac{U_{total}}{\lambda_{total}} , \quad (6)$$

$$EENS = P * U_{total} , \quad (7)$$

where P is the active power generation capacity of the network.

Finally, the values of MTTF, MTTR and FOR of the elements are calculated as follows:

$$MTTF = \frac{1}{\lambda_{total}} , \quad (8)$$

$$FOR = (1 - A) = \frac{MTTR}{MTTR + MTTF} . \quad (9)$$

5 Case Study Network: Simulation Results

A. The test network

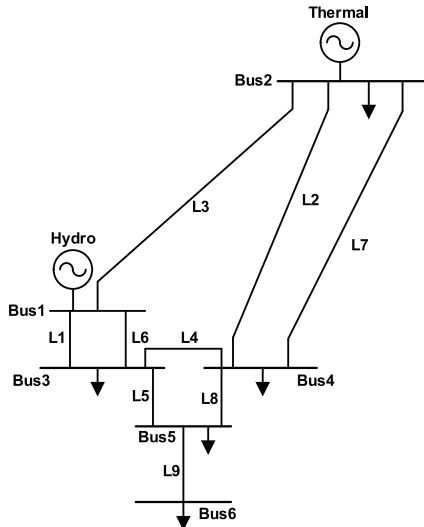

Fig. 6 – 6-Bus IEEE-RBTS network.

To evaluate the effect of powerformers™ on the power system reliability, the 6-bus IEEE RBTS network is chosen [2,14-17]. This test network is shown in Fig. 6.

In the simulation, four different cases are considered for the system. The characteristics of these cases are presented in **Table 2**.

Table 2
Different cases of the system.

Cases	Powerformer™ Location
No. 1 (Basic Case)	Base Case: 3-Bus System with Conventional Generators
No. 2	Replacing Generator at Bus 2 with Powerformer (a 100MW Thermal Power Plant)
No. 3	Replacing Generator at Bus 1 with Powerformer (a 50MW Hydro Power Plant)
No. 4	Replacing all Generators with Powerformer™ Units

The specifications of the base case for the RBTS network are considered in the reference. Then, powerformers™ are replaced with conventional generators. The results for the two situations are compared together. The reliability parameters of the case study network are described in **Table 3** [15-17].

Table 3
IEEE-RBTS network data.

Elements		λ [fail/yr]	r [h]	U [h/yr]
Conventional generators	G1,G2 Hydro (50MW)	0.025	48	1.2
	G3 Thermal (100MW)	0.05	50	2.5
Powerformers	G1,G2 Hydro (50MW)	0.004	96	0.384
	G3 Thermal (100MW)	0.02	100	2.0
Transmission Lines		0.01	10	0.1
Transformers T1, T3, T4, T5		0.02	75	1.5
Transformers T2		0.015	60	0.9
Circuit-breakers		0.015	70	1.05
Disconnect Switch		0.01	20	0.2
Load Bus		0.015	10	0.15
H and B Buses (Reliable)		0.0	0.0	0.0

To explain the system reliability evaluation clearly, consider Fig. 7a. This figure shows the reduced network of Fig. 6 with the same characteristics as with hydro- and thermal power plants as well as a load center. This network has 3 generation units with the total generation capacity of about 200MW (two hydro-power plants each with a capacity 50MW and one thermal unit with a capacity of 100MW capacity). Also, the peak load of the network is 200MW. Fig. 7b shows an equivalent single line diagram to reduce the size of the calculations.

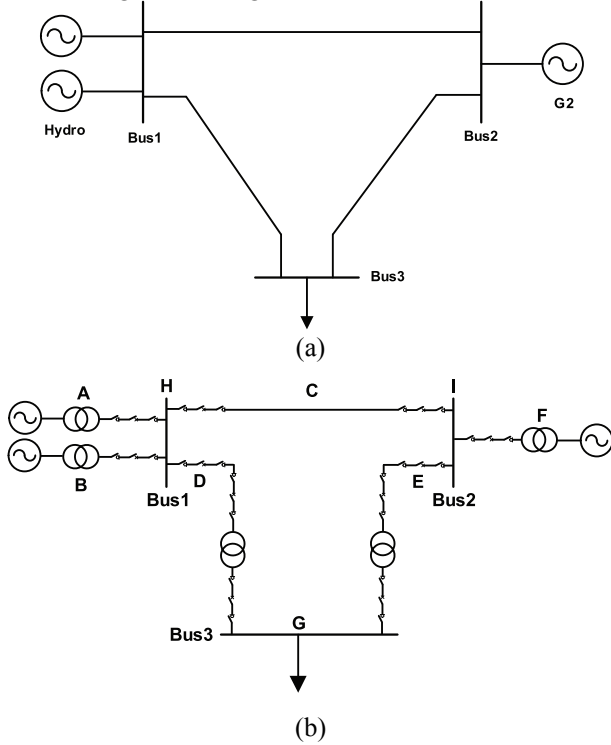

Fig. 7 – Reduced 3-Bus IEEE-RBTS network (system peak load =200 MW)
 (a) Reduced single line; (b) Equivalent single line diagram of (a).

It should be noted that the existing elements are the equivalent elements in the network and they are obtained by applying equations (10) to (12) [13].

$$\lambda_T = \sum_{i \in A} \lambda_i \quad [\text{fail/yr}], \tag{10}$$

$$U_T = \sum_{i \in A} \lambda_i r_i = \text{EDLC} \quad [\text{h/yr}], \tag{11}$$

$$r_T = \frac{U_T}{\lambda_T} \quad [\text{h}]. \tag{12}$$

Now consider the equivalent elements, the 6 paths in the system are:

AHDG, AHCEG, BHDG, BHCEG, FICDG, FIEG.

Assume that the power plant busbars (H and I buses) are reliable, then these paths can be modified as:

ADG, ACEG, BDG, BCEG, FCDG, FEG.

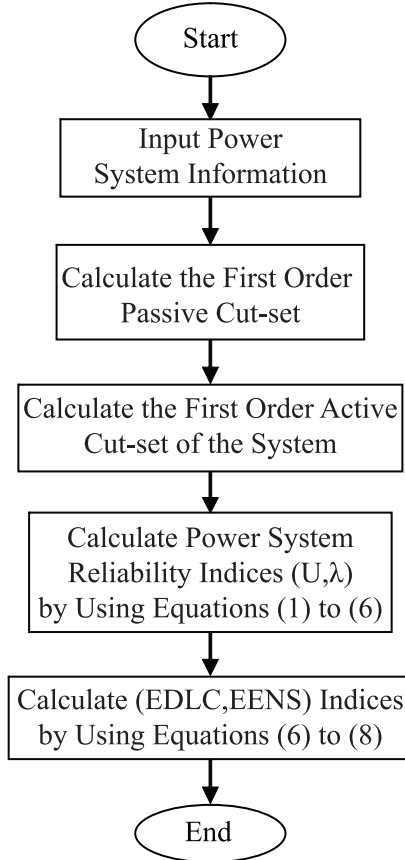

Fig. 8 – *Flowchart for the proposed methodology.*

To find the paths and minimal cut-sets, the MATLAB software is used. The minimal paths are:

G, DE, ABF, CDF, ABCE.

The simulation flowchart is shown in Fig. 8. As mentioned earlier in this paper, the mean value of failure rate [failure/yr], mean down time [h], expected duration of load curtailment (EDLC with h/yr), expected energy not served, or loss of energy expectation index have been considered as reliability indices for the system.

B. Comparison of the results for different cases

Table 4 shows the simulation results in each of the four cases given in **Table 2**. In this table, the values of reliability indices of all various cases are shown separately. The first column of the table denotes the failure rate in each case. The repair time values are shown in the second column. The third column is a representative of EDLC index and finally, the last column is the EENS values. As **Table 4** shows, the values of reliability indices have been improved by changing the type of the generators and the location of powerformersTM. For example, in Case 2, when a conventional generator of 100MW thermal power plant is replaced by a powerformerTM, a 3.6% improvement can be found in EDLC and EENS indices (from 444.91 h/yr to 428.381 h/yr, respectively).

Table 4
System indices for different cases (system peak load =200 MW).

Index Case	λ_T [fault/yr]	r_T [h]	EDLC [h/yr]	EENS (MWh/yr)
No. 1	0.021598	2.349334	444.499	10.1484
No. 2	0.021350	2.290476	428.381	9.7804
No. 3	0.020537	2.084606	375.033	8.5624
No. 3	0.019493	1.799752	307.327	7.0166

This quantity will be improved in the Case 3 of **Table 4** to the amount of 15.6% when compared with the basic case by changing the type of generator and location of the powerformerTM.

The most improvement of reliability indices of the network can be seen in Case 4. In this case, all the network conventional generators have been replaced with powerformersTM. In this case, the improvement amounts of EENS and EDLC indices are about 30.8% of the basic case (Case 1). Such significant improvement in the reliability indices is very important. It should be noted that through economical considerations, this must be performed when all conventional generators are going to be replaced with powerformersTM in electric systems.

In general, placing a powerformerTM with a 100MW capacity in a thermal power plant as in Case 2 is equal to including a new power plant with a generating energy of 368 kWh/yr, equal to the installation of a power plant with a generating energy of 1568 kWh/yr and 3131 kWh/yr as in Cases 3 and 4, respectively. Variations of the two reliability indices (EDLC and EENS indices) in the four cases of the network are illustrated in Figs. 9a and 9b. The simulation results clearly show that first, the presence of a powerformerTM causes a significant improvement in the reliability indices. Second, the improvement value largely depends on the type of the power plant (hydro- or

thermal unit), location of the powerformer™ in the power system (load center or off the load center), load level of the system and the network topology (loop or radial). Also, in Figs. 10a and 10b repair rate and failure rate indices of all cases are shown, respectively. This figure shows that the repair rate and the failure time are reduced by replacing the powerformer™ with the conventional generator.

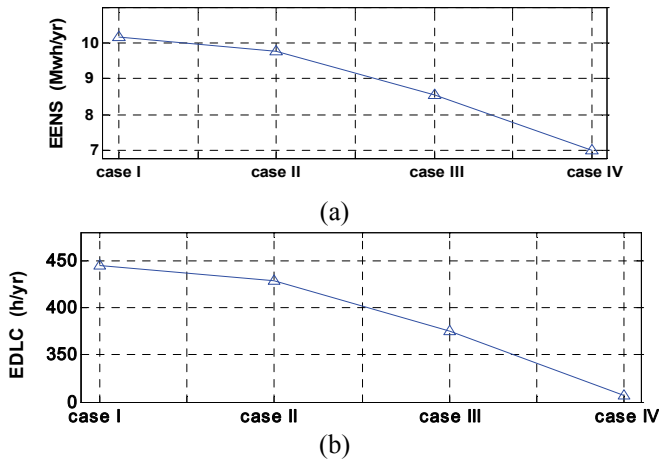

Fig. 9 - EENS & EDLC indices for different cases
 (a) EENS Index; (b) EDLC Index.

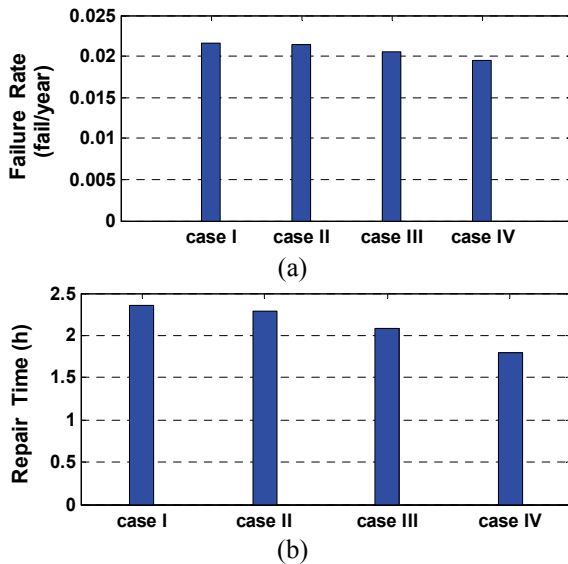

Fig. 10 – System indices for different cases (system peak load =200MW)
 (a) Failure rate index; (b) Repair time index.

6 Conclusion

In this paper, the effect of a new type of generator called powerformersTM on the power system reliability was evaluated. In this regard, after introducing the terms related to the reliability indices for the powerformersTM, four different cases of a network with conventional generators were considered. In all the cases, the conventional generators were gradually replaced with the powerformersTM. The simulation results showed that the use of powerformersTM in power systems has significant advantages in the reduction of EDLC and EENS indices, and it also has remarkable improvement in other indices of the system reliability. The improved values of the system reliability indices depend largely on the type of the power plant, location of the powerformerTM, load level and the network topology. Moreover, it was shown in this paper that by increasing the number of powerformersTM in the electric power system, the reliability parameters were improved.

7 References

- [1] M. Banejad, R.A. Hooshmand, M. Moazzami: Evaluation the Effects of the Synchronous Generator Circuit Breaker on the Reliability of Busbar Layout in Power Plant Substation in Deregulated Electricity Market, 5th International Conference on European Electricity Market, EEM 08, 28-30 May 2008, pp. 1 – 6.
- [2] P. Wang, R. Billinton: Reliability Assessment of a Restructured Power System using Reliability Network Equivalent Techniques, IEE Proceedings Generation, Transmission and Distribution, Vol. 150, No. 5, Sept. 2003, pp. 555 – 560.
- [3] V. Gurevich: Reliability of Microprocessor-Based Relay Protection Devices: Myths and Reality, Serbian Journal of Electrical Engineering, Vol. 6, No. 1, May 2009, pp. 167 – 186.
- [4] M. Leijon, F. Owman, T. Sorqvist, C. Parkegren, S. Lindahl, T. Karlsson: PowerformerTM: A Giant Step in Power Plant Engineering, IEEE Electric Machines and Drives, International Conference IEMD 99, 9-12 May 1999, pp. 830 – 832.
- [5] G. Baojun, Z. Jian, L. Peng, C. Zengfen: Analysis and Calculation of the Operation Characteristics for Powerformer, Power and Energy Engineering Conference, Asia-Pacific, APPEEC., 27-31 March 2009, pp. 1 – 4.
- [6] M. Darveniza, T.K. Saha, B. Berggren, M. A. Leijon, P. O. Wright: A Research Project to Investigate the Impact of Electricity System Requirements on the Design and Optimal Application of the PowerformerTM, IEEE Power Engineering Society Transmission and Distribution Conf., Vol. 1, 2001, pp. 504 – 509.
- [7] M. Wahlen, B. Larsen, M. Lindgren, B. Hernas, P. Frost: Risk Assessment of a Highvoltage Generator with XLPE Insulated Stator Windings, CIGRE, Paris, Special Session, 2002.
- [8] T.R. Limbu, T.K. Saha, J.D.F. McDonald: Cost/Benefit Analysis of Generation Investments Considering System Constraints, IEEE Power Engineering Society General Meeting, 24-28 June 2007, pp. 1 – 8.
- [9] T.R. Limbu, T.K. Saha, J.D.F. McDonald: Probabilistic Cost Benefit Analysis of Generation Investment in the Deregulated Electricity Market, IEEE Power Engineering Society General Meeting, 18-22 June 2006, pp. 1 – 7.

- [10] C.A. Aumuller, T.K. Saha: Investigating the Impact of Powerformer™ on Large Scale System Voltage Stability, IEEE Power Engineering Society General Meeting, 12-16 June 2005, pp. 1283 – 1289.
- [11] S. Lindhal, M. Leijon: Estimation of the Reliability of Powerformer™, SECRC/ABB Corporate Research, Vasteras, SEGEN/DN HOG 9801, 1998, pp. 1 – 6.
- [12] T.R. Limbu, T.K. Saha: Investigations of the Impact of Powerformer™ on Composite Power System Reliability, IEEE Power Engineering Society General Meeting, 12-16 June 2005, pp. 2090 – 2097.
- [13] R. Billinton and R.N. Allan: Reliability Evaluation of Power Systems, 2nd Edition, Plenum Press, New York, 1996.
- [14] R. Billinton, S. Kumar, N. Chowdhury, K. Chu, K. Debnath, L. Goel, E. Khan, P. Kos, G. Nourbakhsh, J.A. Oteng: A Reliability Test System for Educational Purposes – Basic Data, IEEE Trans. on Power Systems, Vol. 4, No. 3, Aug. 1989, pp. 1238 – 1244.
- [15] R. Allan, R. Billinton: Power System Reliability and its Assessment Part-I. Background and Generating Capacity, Power Engineering Journal, Vol. 6, No. 4, July 1992, pp. 191 – 196.
- [16] R. Billinton, R.N. Allen: Reliability Evaluation of Engineering system, Plenum Press, First Edition 1983.
- [17] R. Billinton and R. Allan: Reliability Assessment of Large Electric Power Systems, Kluwer Academic Publishers, Boston, 1988.
- [18] M. Vega, H.G. Sarmiento: Algorithm to Evaluate Substation Reliability with Cut and Path Sets, IEEE Transactions on Industry Application, Vol. 44, No. 6, Nov.-Dec. 2008, pp. 1851 – 1858.