

3D Numerical Modelling of Coupled Phenomena in Induced Processes of Heat Treatment with Malice

Peeteenut Triwong¹, Annie Gagnoud²

Abstract: This paper describes a multi-method Malice package for three dimension coupled phenomena in induced processes of heat treatment by an algorithm weakly coupled with the Migen package integral method defining the electromagnetic model and the Flux-Expert package finite element method defining the thermal model. The integral method is well suited to inductive systems undergoing sinusoidal excitation at midrange or high frequency. The unknowns of both models are current density, scalar potential and temperature. Joule power in the electromagnetic model is generated by Eddy currents. It becomes the heat source in the thermal model.

Keywords: Electromagnetism, Heat transfer, Numerical method, Coupled phenomena, Coupled algorithms.

1 Introduction

In induced processes of heat treatment, a sinusoidal variation of the exciting current creates eddy currents in the material to be melted. The installation mainly consists of an inductor coil surrounding a crucible that contains the load. The load is a conducting material or a non conducting material. The materials are exposed to relatively high frequencies (kHz). The electromagnetic model including skin effects in linear materials is important in order to know global quantities such as Joule power, electrical impedance, and local values of parameters such as power density and electromagnetic forces. The integral method uses the current density \vec{J} and the electrical potential V ; it is based on the local Ohm's law, the Biot-Savart relationship and the conservation of current [1]. Only the active electrical part of the domain is meshed. These physical relationships are used directly in the numerical formulation, which leads to a linear system. It is possible to calculate the local values for power density and force density as well as global values such as Joule power and electrical impedance. The thermal model, i.e. the finite element method uses the

¹Laboratory SIMAP, EPM-MADYLAM group, ENSEEG, B.P. 75, 38042 Saint-Martin d'Hères, France, E-mail: peeteenut@hotmail.com

²Laboratory SIMAP, EPM-MADYLAM group, ENSEEG, B.P. 75, 38042 Saint-Martin d'Hères, France, E-mail: annie.gagnoud@grenoble.cnrs.fr

temperature T ; it is based on the classical heat transfer equation. This equation can involve boundary conditions at the interfaces by Gauss's theorem [2]; convection and radiation at the interface between the load and the air, prescribed heat flux or temperature and the heat dissipated in the part by eddy currents being the main source of temperature evolution in the load [3].

For 3D numerical simulation of coupled phenomena in the weakly coupled method, we used the multi-method Malice package enabling modelling coupled phenomena in the induced processes [4].

2 Numerical method

The objective of this work was to implement a coupled method based on modeling of 3D configurations. We used interpolation, derivation and integration techniques commonly used for the integral method and finite element methods.

2.1 Electromagnetic model

The two equations on which the model is based are:

- The local Ohm's law equation

$$, \vec{J} + \sigma \frac{\partial \vec{A}}{\partial t} + \sigma \vec{\nabla} V = 0 \quad (1)$$

where \vec{J} is the current density, σ is the electrical conductivity, V is the electrical scalar potential, \vec{A} is the magnetic vector potential and t is time.

- The equation for the conservation of current

$$\nabla \cdot \vec{J} = 0. \quad (2)$$

The local expression of the potential vector is obtained by the Biot-Savart law

$$\vec{A} = \iiint_{\Omega} \frac{\mu_0 \vec{J}}{4\pi r} dV. \quad (3)$$

Ω represents the volume of the conductors, μ_0 is the magnetic permeability of air, r represents the distance between the point concerned (point where the potential is calculated) and the source point in the volume Ω . This relationship implicitly takes into account the boundary condition at infinity. Given the alternating nature of the exciting current; a complex notation is required to express the electromagnetic quantities relation (1) as:

$$\vec{J}_c = -\sigma \vec{\nabla} (V_c) - i_c \sigma \omega \vec{A}_c. \quad (4)$$

The subscript c denotes the complex value of the variable, ω is the angular frequency and $i_c = \sqrt{-1}$. When the Biot-Savart law (3) is substituted in Ohm's law (4) we obtain an integral relationship between the current density and the electrical potential

$$\bar{J}_c = -\sigma \bar{\nabla}(V_c) - i_c \sigma \omega \iiint_{\Omega} \frac{\mu_0 \bar{J}_c}{4\pi r} dV. \quad (5)$$

Our electromagnetic problem can then be described by (2) and (5). These relations only apply to conducting regions. Note that with this approach, the current density and potential become the unknowns.

The electromagnetic skin depth is defined by

$$\delta = \sqrt{\frac{2}{\sigma \mu \omega}}. \quad (6)$$

If the electromagnetic skin depth is very small compared to the size of the load we call this case the thin skin depth case. Then it is possible to apply an exponential decay when the 1-D approximation is valid

$$\bar{J}_c = \bar{J}_{c,s} e^{-\frac{(1+i)n}{\delta}}, \quad (7)$$

where $\bar{J}_{c,s}$ is the complex value of current density at the surface of the conductor, and n is the distance of an internal point to the surface in the direction normal to the surface. In this case the surface of the conductor is mesh.

For the integral method, the electrical potential scalar and the current density are interpolated using the first-order Lagrange polynomial.

2.2 Thermal model

The equation on which the model is based is:

- The classical heat transfers equation

$$\rho C_{Total} \frac{DT}{Dt} + \bar{\nabla} \cdot (-k_{th} \bar{\nabla} T) - Q_{th} = 0, \quad (8)$$

where T is the temperature of the conductor, ρ is the density, C_{total} is the total specific heat capacity, k_{th} is the thermal conductivity, Q_{th} is the heat source and t is time. We defined the boundary conditions at the interfaces by Gauss's theorem

$$-(k_{th} \bar{\nabla} T) \bar{n} = h_{cv} (T - T_a) + \sigma_{SB} \varepsilon (T^4 - T_a^4) + \text{Flux}, \quad (9)$$

where h_{cv} is the convection heat transfer coefficient, σ_{SB} is the Stefan-Boltzmann constant, ε is the emissivity, T_a is the room temperature and $Flux$ is the heat flux at the surfaces. For the finite element method, the interpolation functions are created by Galerkin's approximation and a Lagrange polynomial function of the second order. Then we can write this equation in the form of an integral with boundary conditions (method of weighted residuals by Galerkin):

$$\begin{aligned} & \iiint_{\Omega} \alpha_i \rho C_{total} \frac{\partial T}{\partial t} dV + \iiint_{\Omega} k_{th} \bar{\nabla} \alpha_i \bar{\nabla} T dV + \iint_{\Gamma} \alpha_i h_{cv} T dS + \iint_{\Gamma} \alpha_i \sigma_{SB} \varepsilon T^4 dS \\ & = \iiint_{\Omega} \alpha_i Q_{th} dV + \iint_{\Gamma} \alpha_i h_{cv} T_a dS + \iint_{\Gamma} \alpha_i \sigma_{SB} \varepsilon T_a^4 dS + \iint_{\Gamma} \alpha_i Flux dS. \end{aligned} \quad (10)$$

2.3 Coupled model

Numerical simulation generally leads to thermo-electromagnetic equations by a weakly coupled method. For this, we used the Malice package. It is the result of coupling of the Migen 3D electromagnetic package (integral method) and a Flux-Expert generator of partial derivative equations (finite element). Meshes of the charge in the integral method and in the finite element method are different for the thin skin depth problem of the electromagnetic model. Interpolations are necessary for calculation of model coupling. The solution for the interpolation of coupling's term:

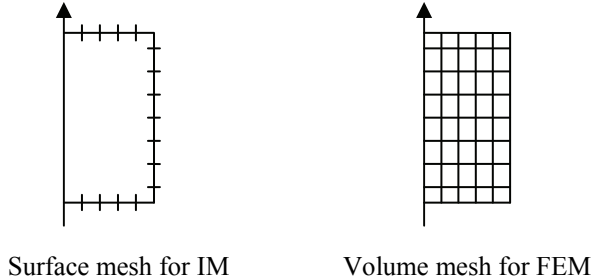

Fig. 1 – Mesh of a coupled model for the integral method and finite element method.

Interpolation IM → FEM

- 1) Find the orthogonal projective's integration point of the finite element mesh at the domain surface.
- 2) Calculate the current density at the orthogonal projective point.
- 3) Calculate the heat source of integration point by the exponential decay law as a function of the distance between the orthogonal projective and integration point:

$$Q_{th} = P_J \cdot e^{-\frac{2n}{\delta}}, \quad (11)$$

where Q_{th} is the heat source of the integration point, $P_J (= J \cdot J^* / 2\sigma)$ is the Joule power density of the electromagnetic model at the point orthogonal projective.

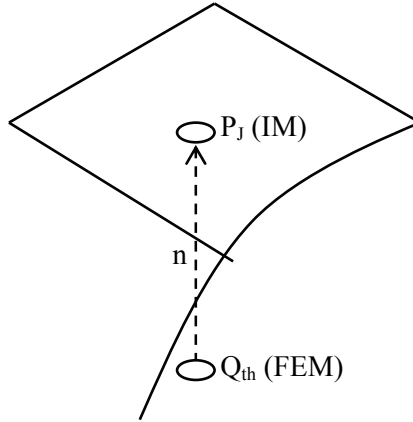

Fig. 2 – Interpolation between the integral method and finite element method.

This numerical formulation leads to a linear system:

$$\mathbf{M}\mathbf{I} = \mathbf{K}_S. \quad (12)$$

For the electromagnetic model, \mathbf{M} is a full non symmetric matrix, \mathbf{I} is the vector of unknowns constituted by the components of the current densities and the electrical potential, and \mathbf{K}_S is the second vector of the system that is equal to the vector potential created by the coil when the current density is imposed in the coil. The terms \mathbf{M} , \mathbf{I} , \mathbf{K}_S are constituted by complex numbers. To solve this system, the Gauss method with a total pivot is used.

For the thermal model, \mathbf{M} is a sparse symmetric matrix, \mathbf{I} is the temperature unknown, and \mathbf{K}_S is second vector of the system that is equal to the boundary conditions at the interfaces. The terms \mathbf{M} , \mathbf{I} , \mathbf{K}_S are constituted by real numbers. To solve this system, the iterative method is used.

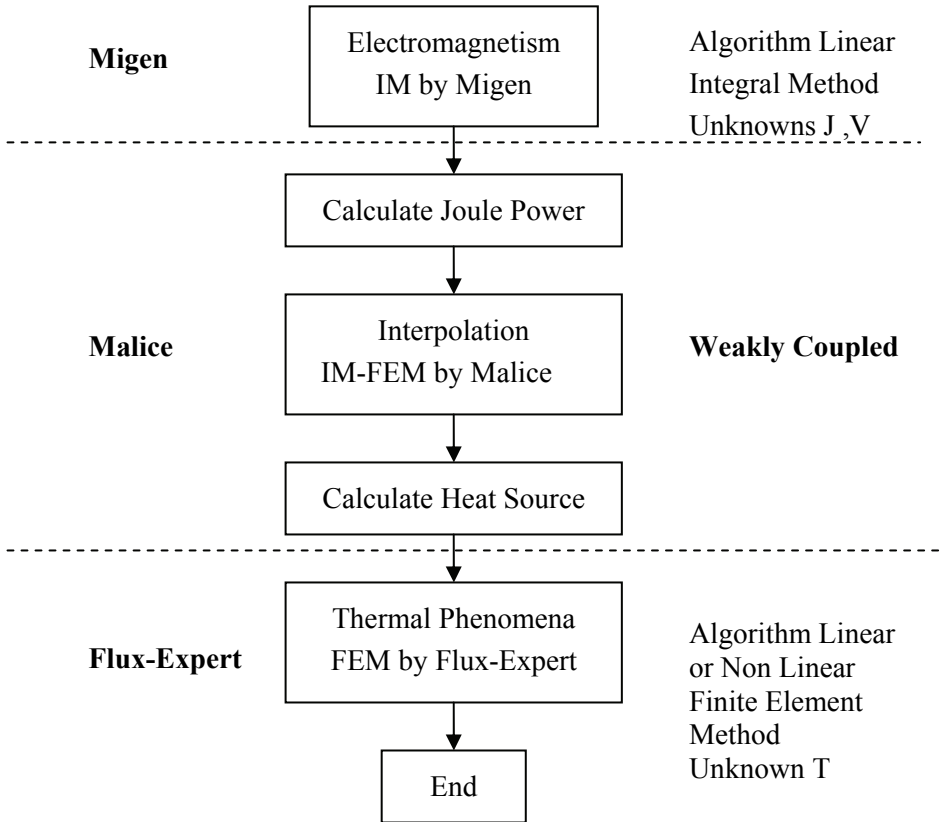

Fig. 3 – General coupling algorithm.

3 Numerical results

3.1 Configuration

We have studied a simple problem consisting of a hexahedron shaped load and 5 square inductors. The height of the hexahedron is 0.1m and its sides measure 0.06m. It is made of copper. The electric conductivity σ is $5 \times 10^7 \Omega^{-1} \text{m}^{-1}$. The thermal conductivity k_h is 400 W/mK. The specific heat C_p is 385 J/kgK. The length of the sides of the square turns of the inductor is 0.08m. The numerical simulation is carried out for a frequency of 20 kHz and coil current of 1000 A. (Fig. 4)

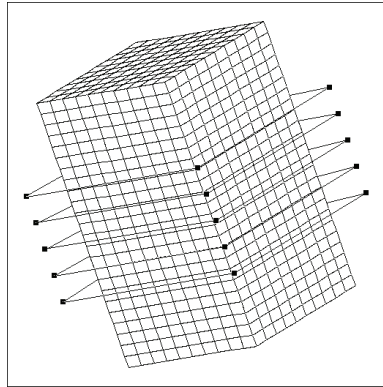

Fig. 4 – 3D Mesh of conductor and 5 square inductors.

3.2 Electromagnetic results

This section presents an analysis of the distribution of current densities. The δ value is 0.5 mm (thin skin case). Then we use the thin skin depth model to solve the electromagnetic problem. For this case the surface of load is mesh. The load has 2400 elements. Figs. 5a and 5b show the current density vectors on the surface of the conductor hexahedron (for thin-skin conditions). The direction of the vectors is horizontal, turn around the load and opposite the current direction of inductor coils. The current density maximum is $0.16 \times 10^9 \text{ J/m}^2$.

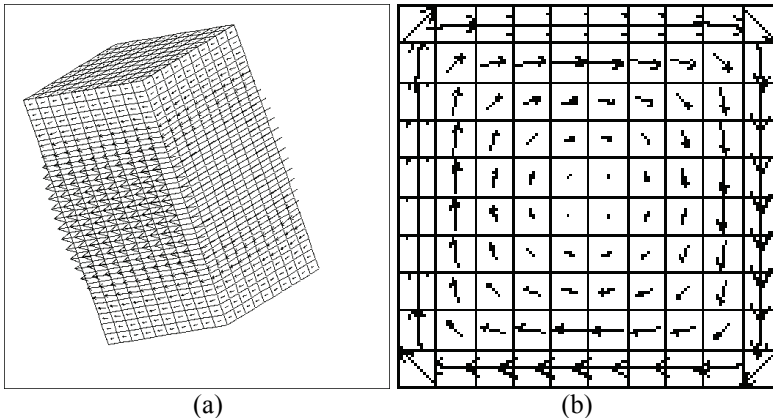

Fig. 5 – Current density vectors: (a) 3D; (b) horizontal top plan.

The Joule power which is induced in the load by the current densities is 1285 W. It will become the heat source in the thermal problem by a weakly coupled method.

3.3 Thermal results

For this section, we used the static linear algorithm for calculation and analysis of the distribution of the heat source and temperature in the load. We defined the value of condition limits as:

- 1) convection heat transfer coefficient h_{cv} is $80 \text{ W/m}^2\text{K}$;
- 2) temperature of air T_a is 300K .

Fig. 6 shows the heat source Q_{th} originating from the Joule power density of the electromagnetic problem. The heat source has a high value and very thin skin at the surface around the load (Fig. 7).



Fig. 6 – Heat sources in the conductor at horizontal plan.

FLUX-EXPERT CONFIG 12/12/07 17:35

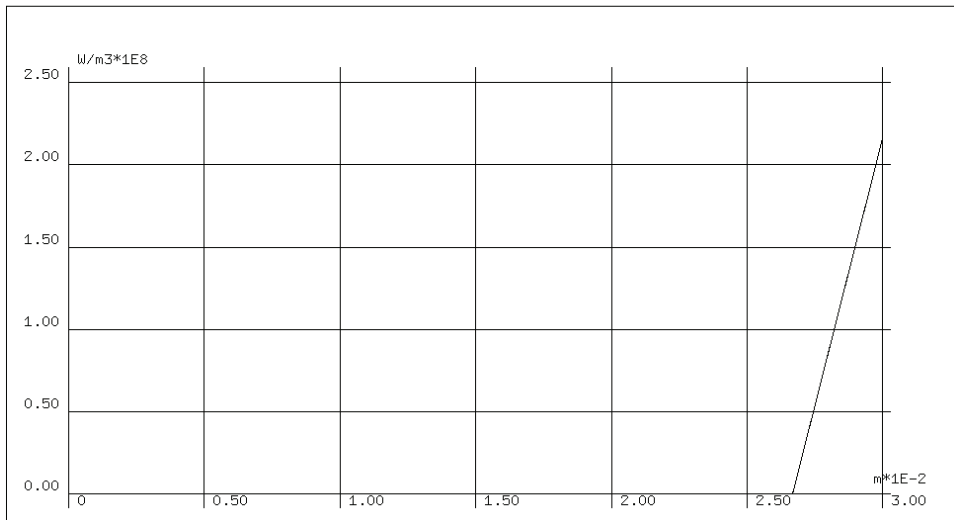

Fig. 7 – Graph of Joule power density at the centre to the surface of load.

In the coupled Malice model the number of elements is important in giving the correct heat source value. For this simple problem we showed the charge with a different number of elements in the thermal model compared to the value of the obtainable heat source. Then, Fig. 8 shows the load which has a different number and different position of elements.

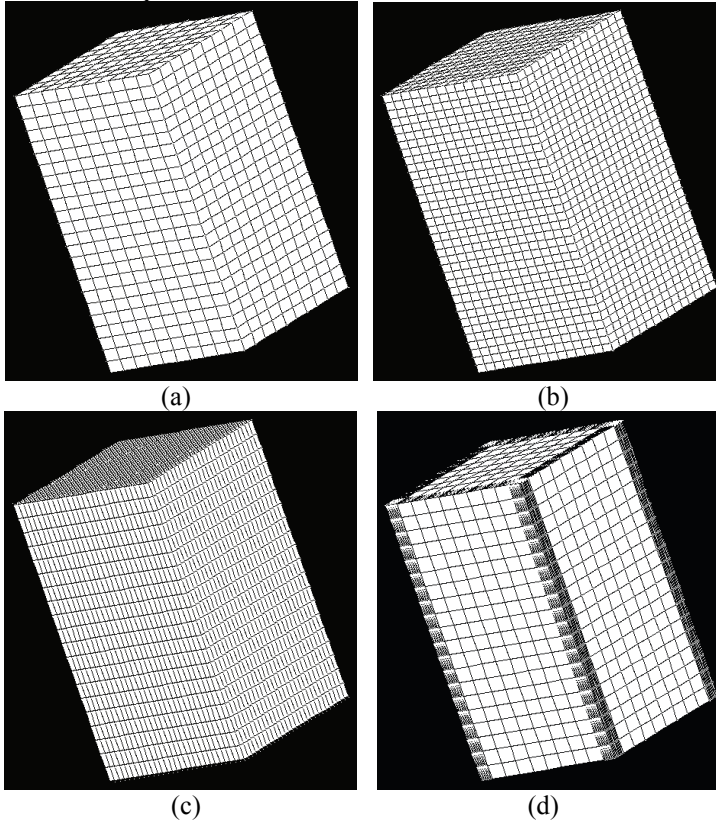

Fig. 8 – 3D mesh of Flux-Expert charge: (a) 2400 elements; (b) 8100 elements; (c) 15680 elements; (d) 15680 elements (thin elements at the surface).

Table 1

Comparison of the results obtained for different meshes of thermal problem.

No.	Number of elements thermal	Joule Power by IM (W)	Joule Power by FEM (W)	T_K max (K)	%Error of Power
Mesh 1	2400	1285	585	538	54.5
Mesh 2	8100	1285	942	682	26.7
Mesh 3	15680	1285	1227	799	4.5
Mesh 4	15680	1285	1282	821	0.2

Table 1 presents, the number of elements, Joule power of the load calculated by the integral method, Joule power of the load calculated by the finite element method (heat source), interpolated temperature maximum and percent of error of interpolation for each element. From **Table 1** we can see, that the charge number when the value of the heat source is close to the value of Joule power and gives the temperature maximum is No. 4.

This problem is the thin skin case. The heat source appears at the surface around the load. Then we must create thin elements at the surface of the thermal model for interpolation of the coupling term.

From Fig. 9, we can see that the highest temperature is apparent at the corner of the charge and the lowest temperature is apparent at the surface on the top and the bottom of the charge.

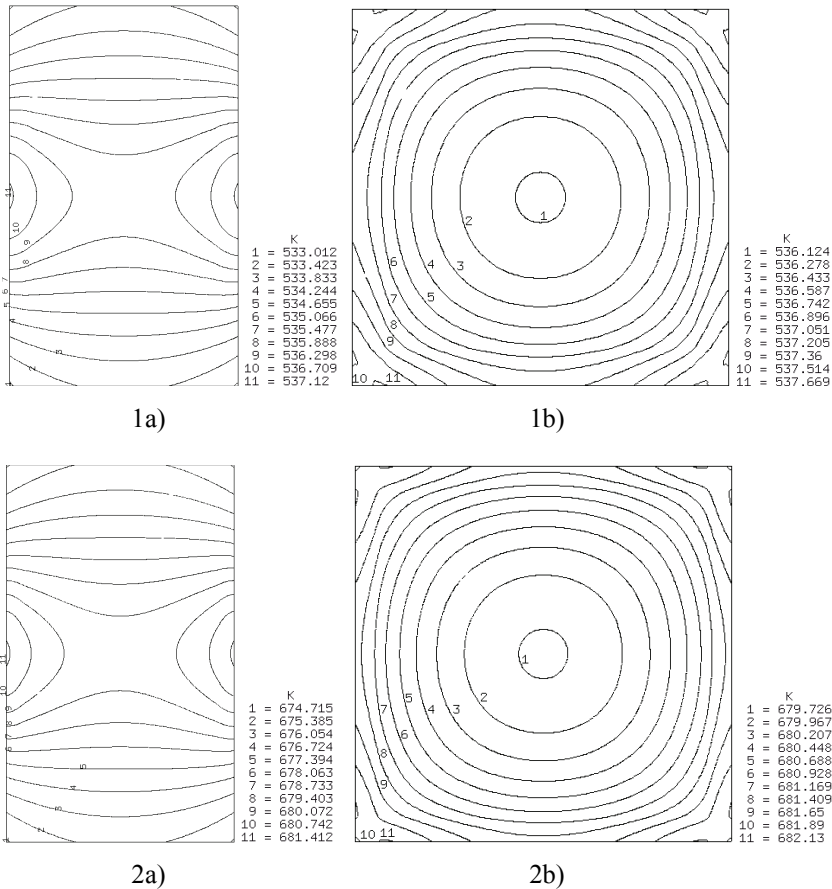

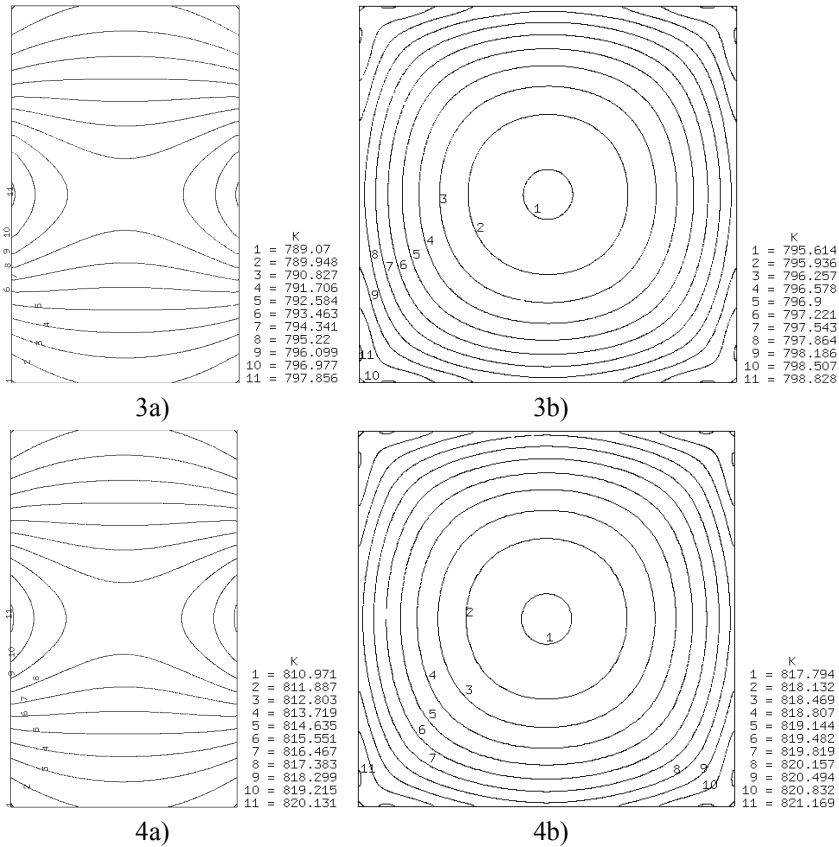

Fig. 9 – Temperature profile: a) vertical-centre plan; b) horizontal-centre plan.

4 Conclusion

The main propose of this paper was to solve thermo-electromagnetic problems in the weakly coupled method with the finite element mesh difference. Interpolation between the integral method and finite element method for calculation of the heat source in the model coupling is necessary. The number and position of elements is important to be able to give the correct results of the coupling problem.

5 References

- [1] A. Gagnoud: Three-Dimensional Integral Method for Modeling Electromagnetic Inductive Processes, IEEE Transactions on Magnetics, Vol. 40(1), 2004, pp. 29-36.
- [2] J. Morandini, Y. du Terrail Couvat, Ph. Massé: Résolution des Equations Thermo-Electrique 3D Couplées par la Méthode de Element Finis. Application à un Four Polyphasé, J. Phys. III France 2, 1992, pp. 1979-1990.

- [3] F. Bay, V. Labbe, Y. Favennec, J. L. Chenot: A Numerical Model for Induction Heating Processes Coupling Electromagnetism and Thermomechanics, *Int. J. Numer. Meth. Eng.*, Vol. 58, 2003, pp. 839-867.
- [4] S. Servant, D. Saumabere, A. Gagnoud, Y. du Terrail Couvat: Malice : un Logiciel Couplant la Méthode Intégrale et la Méthode des Element Finis. Application à la Fusion des Oxydes, *J. Phys. III France 2*, 2002, pp. 1991-2004.