

## Hybrid Reed - Solid-State Devices are a New Generation of Protective Relays

Vladimir Gurevich<sup>1</sup>

**Abstract:** Research and development in the field of electromechanical protective relays has not been conducted for tens of years. Author's approach allows viewing the problem of re-equipment of relay protection in a new way. In the author's opinion combination of reed switches with magnetic circuits and semiconductor elements opens new avenues in development of the promising protective relays featuring reliability, simplicity and low cost. Examples of protective relays made with these elements are given below.

**Keywords:** Hybrid relays, Reed switch, Solid-state device, Relay protection, Over-current relay.

### 1 Introduction

In the past few years small-sized standard case TO-247, TO-220 thyristors and transistors intended for soldering on the printed-circuit-board for the switching of current of tens of amperes at voltages of 1200-1600V have appeared.

Various companies manufacture miniature high-speed (fractions of milliseconds) vacuum reed switches that can withstand voltages of 1000 - 2500V which can serve as precision threshold (pickup) elements in the protective relays. The Japanese company Yaskawa and its branches manufacture a series of middle size powerful reed switches for switching currents of up to 5A at a voltage of 250 V (Fig. 1).

When using reed switches it should be kept in mind that their high reliability will be guaranteed only when observing the restrictions imposed by the switching ability determined in the technical specifications. As in semi-conductor switches, the reed switches quickly fail when the allowed switching parameters are exceeded even for a short time. At the same time, even though modern reed switches are electromechanical elements, their reliability and number of switching cycles is closer to that of semi-conductor elements, and so are many of their parameters, such as withstanding electromagnetic interferences, surge

---

<sup>1</sup>Central Electric Laboratory, Israel Electric Corp., POB 10, Haifa, 3100 Israel  
E-mail: vladimir.gurevich@gmx.net

capability, etc. It should be pointed out they considerably surpass semi-conductors in withstanding surges. Because of extraordinary features of the reed switch relays, not possessed by usual electromechanical relays, such as high speed, precise and stable pickup value, and high release factor on an alternating current, etc., many devices for protection and automation systems in the industry, power engineering and military techniques have been developed on their basis.

**Table 1**  
Main parameters of the modern power thyristors,  
suitable for mounting on PCB.

Parameter/ Thyristor type	30TPS12	25TTS12	70TPS16	CS60- 16io1	BTW 69-1200	CS 29-12io1C
Case	TO- 247AC	TO- 220AC	SUPER 247	PLUS247	TOP3	ISOPLUS 220
Max. off-state peak voltage, V	1200	1200	1600	1600	1200	1200
Max. on-state rms current, A	30	25	70	75	50	35
Peak, ½ cycle surge current, A	300	300	1200	1500	580	200
dv/dt, V/μs	500	500	500	1000	1000	1000
di/dt, A/μs	150	150	150	150	50	150
Leakage current (t = 25°C), A	0.5	0.5	1.0	0.2	5	2
Holding current, mA	100	150	200	200	150	50
Turn-on time, μs	0.9	0.9	-	2	-	2

**Table 2**  
Main parameters of the modern power high-voltage IGBT.

Parameter/ Transistor type	IXSK35N1 20AU1	APT35 GN120N	FGA25N 120ANTD	IXGH 25N160	FGA50N 100BNTD
Case	TO-246AA	TO-247	TO-3P	TO-247	TO-3P
Max. collector- emitter voltage, V	1200	1200	1200	1600	1000
Continuous collector current, A	35	94	25	75	50
Pulsed collector current, A	140	105	90	200	100
Total power dissipation, W	300	379	312	300	156
Collector-emitter ON voltage, V	4	2.5 – 4.7	2.15	2.5 – 4.7	2.0
Turn-ON delay time, ns	80	24	50	47	140
Turn-OFF delay time, ns	900	300	190	86	630

Hybrid Reed - Solid-State Devices are a New Generation of Protective Relays

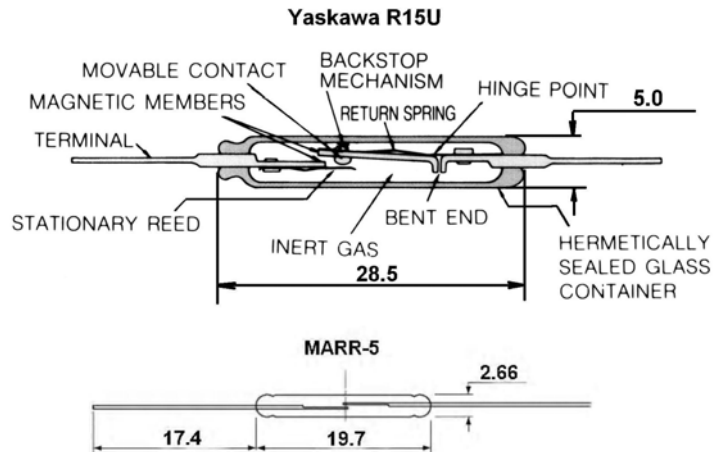

**Fig. 1** – Modern reed switches, recommended for use in the protective relays.  
 At the top: gas filled power reed switch R15U (Yaskawa);  
 at the bottom: miniature high-speed vacuum reed switch MARR-5 (Hamlin Inc.).

**Table 3**  
 Main parameters of high-speed vacuum high-voltage reed switches.

Parameter/ Reed switch type	MRA5650G	KSK-1A75	HYR2016	HYR1559	MARR-5	R1-48C
Contact form	NO	NO	NO	NO	NO	NO
Max. switching voltage, V	1000	1000	1000	1500	1000	250
Max. switching current, A	1	0.5	1	0.5	0.5	1
Max. switching power, W	100	10	25	10	10	70
Dielectric strength, V	1500	1500	2500	1500	2000	780
Operate time, ms	0.6	0.5	0.8	0.4	0.75	0.35
Release time, ms	0.05	0.1	0.3	0.2	0.3	0.03
Dimensions, mm	D = 2.75, L = 21	D = 2.3, L = 14.2	D = 2.6, L = 21	D = 2.3, L = 14.2	D = 2.66, L = 19.7	D = 2.7, L = 20.5
Pull in value (AT range)	20 – 60	15 - 40	15 - 70	15 - 50	17 - 38	27 - 80

The combination the reed switches with magnetic circuits and semi-conductor elements opens new avenues in the development of interesting and promising devices distinguished by simplicity and low cost. For example, a simple device such as reed switch with two operating coils, Fig. 2a, can be a basis for creation of the differential protection, logic elements, threshold

summing element, etc. A reed switch with a special magnetic circuit (Fig. 2b) appears to be insensitive to the DC (aperiodical) component of the current in the coil. The reed switch, connected with a simple circuit, Fig. 2c, responds to the voltage asymmetry. In the circuit, Fig. 2d, the reed switch picks up only at rapid changes of current (voltage) in a control circuit which is distinctive for emergency modes and does not respond at slow changes of the current, related to the changes in load, and as described above. The reed switch is also directly responsive to the magnetic field of the current passing in bus bar without additional windings (Fig. 2e).

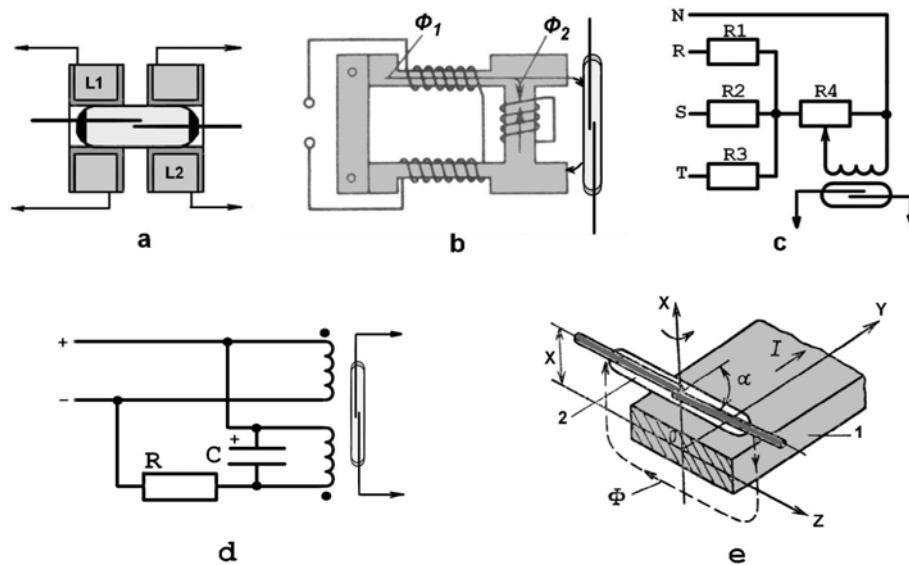

Fig. 2 – Examples of various applications of reed switches in the protection devices.

Let us consider concrete examples of the most widespread kinds of protective relays based on the suggested technology.

## 2 Protective Relays Based On Hybrid Technology

### 2.1 Instantaneous current relay (Fig. 3).

The over-current relays without time delays are widely used for the protection of electric networks and electric equipment against overloads. This version of the relay is intended for directly energizing the trip coil of the high-voltage circuit breaker (CB).

Sensitive threshold (pickup) element of the device is the Rel1 relay made with a miniature high-speed vacuum reed switch. Its coil contains 2050 turns of 0.16 mm wire. At pickup this reed switch starts to vibrate at double the current

frequency. Upon the initial closing of the circuit by the reed switch, thyristor VT will turn-ON and energize the CB trip coil. The thyristor only switches this coil ON; it is switched OFF by the own auxiliary-contact of the CB. Rel2 is an auxiliary relay, intended for signaling or blocking circuits and it uses a medium capacity reed switch such as GC1513. Its coil has very low resistance and it is designed for the short-term carrying of a direct current in a range from 0.5 up to 15 A (typical currents of CB trip coils of various types) at which this reed switch operation is reliable. Adjustment of pickups (coarsening the relay) is carried out with the help of potentiometer R1. In the relay thyristor such as 30TPS12 (in TO-247AC case) is used with rated current 30A and the maximal withstanding voltage of 1200V and miniature vacuum reed switch such as MARR-5. The input CT is made on a low-frequency ferrite ring with the external diameter of 32 mm.

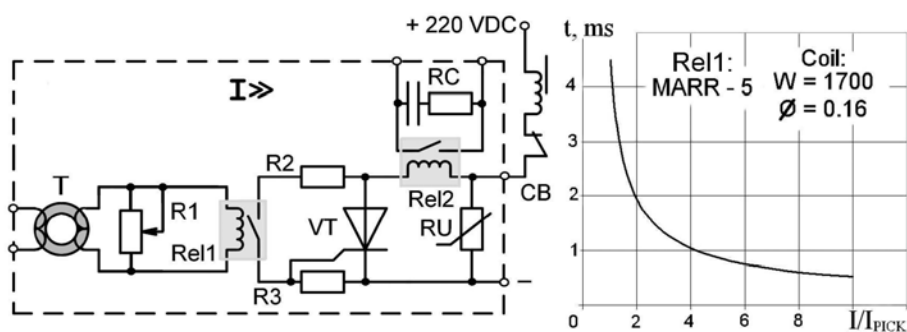

**Fig. 3** – *The simplest hybrid protective relay: instantaneous current relay.*  
*The basic circuit diagram and experimental time-current characteristic curve.*  
 *$I/I_{PICK}$  – multiples of pickup setting.*

RC-circuit serves for protection of the auxiliary contact (reed switch) from spark erosion at switching of inductive loads. Varistor RU such as SIOV-Q20K275 protects the device from spikes in the DC circuit. Its clamping voltage does not exceed 350-420V DC. This voltage level should be higher than the rated voltage of a DC network, but lower than the maximal withstanding voltages of the thyristor and the reed switch. As shown in experimental time-current characteristic curve, the relay speed is higher than that of the electromechanical, static or microprocessor-based devices, it does not need power supply, is insensitive to high-frequency interferences and spikes in a current circuit, and remains reliable at strong distortions of current.

## 2.2 Instantaneous current relay with high release ratio, (Fig. 4).

In this relay design a powerful reed switch, such as R15U (Yaskawa), is used as a contact of tripping output relay Rel2 instead of power thyristor VT.

The second CT (T2) serves as an energy source necessary for the operation of the power reed switch.

Closing and opening reed switch (Rel1) with double the current frequency at energizing does not suit to the operation of relay Rel2. Therefore a special active filter can be used between pickups element Rel1 and output relay Rel2. The filter formed with capacitor C2 (22  $\mu$ F), resistors R2, R3 and transistor VT which can be any low-power transistor for voltages not less than 100V with current gain ( $h_{FE}$ ) not less than 100, for example, such as ZTX753, ZTX953. With a low-power Darlington transistor (for example, such as ZTX605), as shown in Fig. 4, the capacity C2 can be considerably reduced. By means of this filter the current pulsation in the reed switch circuits of Rel1 will be transformed to a stable current in the coil circuit of relay Rel2.

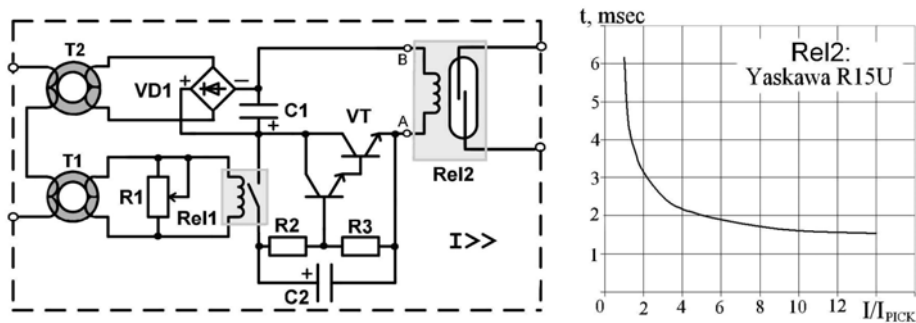
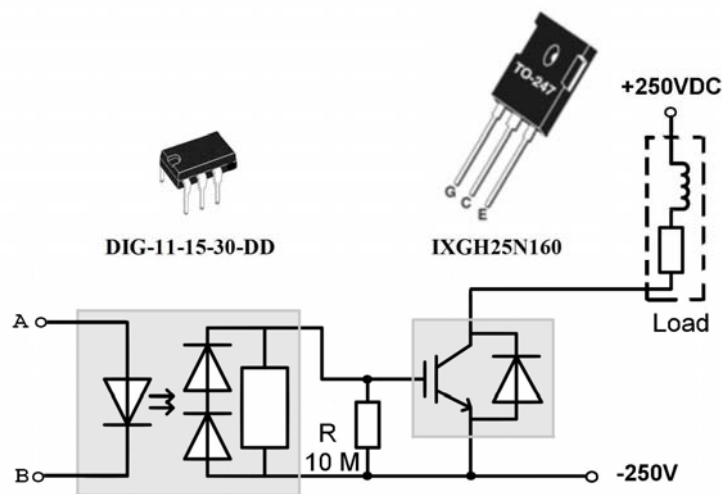

**Fig. 4** – Instantaneous current relay with high release ratio:  
the basic circuit diagram and experimental time-current characteristic curve.  
 $I/I_{PICK}$  – multiples of the pickup setting.

The release ratio of reed switch Rel1 is close to 0.99 at alternating current. For a lower release ratio of the relay (0.7 - 0.6) it is sufficient to connect the Rel1 coil through a rectifier bridge, and to transfer capacitor C2 to a different location, in parallel to this bridge. Since the capacity needed to feed the powerful reed switch is much greater than for a miniature reed switch, CT (T2) is formed with two identical transformers, similar to transformer T1 in which the secondary windings are connected in parallel, and the primary winding - communicating, covers both ferrite rings. The total power consumed by the relay from the current circuit (at a current 5A) does not exceed 4 W. The winding of relay Rel2 consists of two coils placed on the reed switch and connected between them in series. Each of them contains 7600 turns of a 0.08 wire. Experimental time-current characteristic curves (Fig. 4) were obtained for a series of consecutive pickups of the relay, during the time intervals between which the charge of capacitor C1 was kept unchanged. At the initial pickup of

## Hybrid Reed - Solid-State Devices are a New Generation of Protective Relays

the relay with an uncharged capacitor the time delay is approximately twice as long. Such an acceleration of operation in case of repeated pickups at short circuit is a positive property of the protective relay. Even in view of increasing the operation time at the initial pickup, the relay speed still remains very high. Modern IGBT-transistors and complete modules used for their operation (so-called "drivers") enable realization of a very simple switching output unit of the relay on a contact less basis (Fig. 5).



**Fig. 5** – An embodiment of output switching unit of the relay based on the modern IGBT-transistor (IXGH25N160) and specialized driver with the dynamic discharging (DIG-11-15-30-DD) for this transistor control.

### 2.3 Current relays with independent and dependent time delay (Fig. 6)

Similar to the above design, the relay contains two independent current transformers: the first one, T1, is used as a source of control value for the pickups module on the reed switch, Rel1, and the second, T2, for feeding the time delay unit.

When the micro-switch, S, is switched on, the Zener diode, VD3, is connected to the output of rectifier bridge, VD1, and provides a constant level of a voltage (on an input of the time delay unit time) which is independent of the input current in the current pickups range. In this case the relay works with the constant time delays which are determined by capacitance C2 and resistance R2. As this capacitance is charged to a certain voltage value, thyristor, VT1, is turned on and capacitance C2 is completely discharged through low resistance ( $81 \Omega$ ) winding (2050 turns by a wire 0.16) of relay Rel2, activating the reed

switch. In order to turn this device into a relay with time delay depending on the current it is necessary turn the micro-switch, S, to OFF.

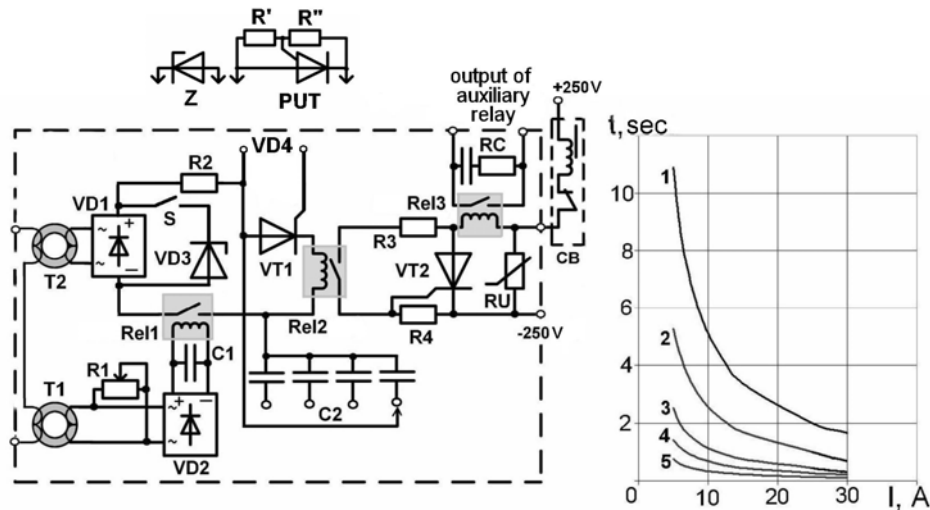

**Fig. 6** – Universal protective current relay with the time delay: the basic circuit diagram and set of experimental time-current characteristic curves. For the relay with the dependent time-current characteristic curves the various values of capacity  $C_2$  (in  $\mu F$ ) are as follows: 1 - 4400; 2 - 3200; 3 - 2200; 4 - 1000; 5 - 300.

In this way the voltage charge of capacitor  $C_2$  will depend on the input current level: the higher the current, the higher the voltage applied to capacitors  $C_2$  and the shorter is the time of their charging up to a voltage level at which thyristor  $VT_1$  turns ON, forming a typical time-current characteristic curve (Fig. 6), of a relay of this kind. If a second reed switch is removed from the center of the coil and mounted in the coil of relay  $Rel_1$  (so that its pickup will be 10 - 15 times higher than that of the first reed switch) and is connected in parallel to reed switch of the relay  $Rel_2$ , the device pickups will be instantaneous at high rates of the input current and energize the trip coil of the CB within 3 - 4 milliseconds. A turned ON thyristor  $VT_1$  was used as the threshold element  $VD_4$ , and a standard Zener diode was used in the relay prototype; however the best results can be obtained with so-called “programmable unijunction transistor” (PUT), e.g., 2N6027, 2N6028 types. This element of the structure and characteristics is similar to a thyristor with very low leakage current (microamperes) through a gate junction that allows more efficient use of capacitance  $C_2$ . Its turn-ON voltage can be adjusted, i.e., “programmed”, by means of resistors  $R'$  and  $R''$ .



## 2.4 Relay of a power direction (Fig. 7).

Even such complex function as detection of power direction can be realized very simply by means of the hybrid technology.

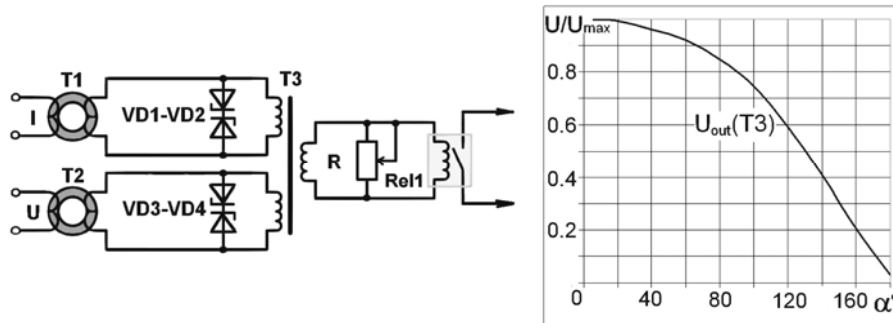

**Fig. 7** – The relay of power direction: basic circuit diagram of measuring the threshold module and experimental dependence of an output voltage of transformer T3 on an angle shift between two voltages on its primary windings.

As it is known, the power direction is determined by the angle of phase displacement between the current and the voltage; therefore, actually, the power direction relay responds to the change of angle between the current and the voltage. It turns out that application of two equivalent phase-shifted voltages to two primary windings of the intermediate transformer T3 causes the output voltage on the third winding to depend very strongly on the phase displacement between these voltages (Fig. 8).

This is necessary only in order to prevent the effect of a change of the input voltage supplied from current transformer, T1, and voltage transformer, T2, at a level of the output voltage of transformer T3. The simplest solution of this problem is provided by means of two back-to-back connected Zeners as it is shown on Fig. 7. A pickup relay can be adjusted by means of potentiometer R.

## 2.5 Relay of differential protection (Fig. 8).

The use of two current transformers (T1 and T2) connected to the input of the pickup module of any of the devices described above enables realizing a two-input relay of differential protection (Fig. 8a).

Interesting opportunities are provided with the use of two separate auxiliary transformers with the secondary windings connected in series in this device. To allow more complex functions, such as decreasing the relay sensitivity with increasing the current carried directly through protected object (so-called “restraint”), an auxiliary transformer, T3, is included in the relay. In addition, the output reed relay Rel1 consists of two windings: L1 - differential and L2 –

restraint, which shift the working point of the relay proportionally to the current carried directly through the protected object (Fig. 8b).

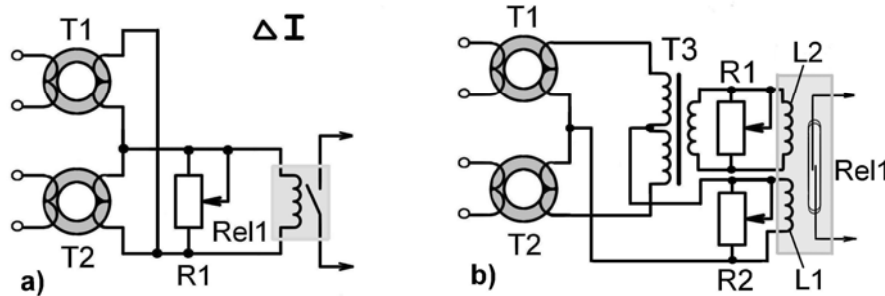

**Fig. 8** – Measuring modules for the relay of differential protection: to the left the simplest embodiment, to the right – an embodiment with restraint.

### 3 Conclusion

Description of quite interesting and promising devices based on the suggested elements could be continued. However, the purpose of this publication is not to present the advantages of reed switches, but to prove that on the basis of a combination of modern reed switches and modern power semi-conductor elements a new generation of hybrid protective relays not including complex mechanisms can be easily created that can replace the out-of-date electro-mechanical relays at the upper level with retaining their high noise and surge stability, maintainability and other positive features. The use of the new generation of the relays would allow sparing considerable financial expenses connected with necessity of purchasing the expensive microprocessor-based protective devices. Thus, further perfection of automatic control systems in electric networks through by equipping them with microprocessor recorders of emergency modes, optical communication systems and other modern systems can be gradually accomplished, during accumulation of financial resources independently of the relay protection. In the author's opinion the above examples of the protective relays developed and tested by the author, can support our conclusion.

### 4 References

- [1] V. Gurevich: Protection Devices and Systems for High Voltage Applications, pp. 293, Marcel Dekker, New York, 2003.
- [2] V. Gurevich: Electric Relays. Principles and Applications, pp. 704, Taylor & Francis Group, 2005.